

HCR50 - 150 ton

HCR200 - 300 ton

Rosca del collar* (pulg)		
Número de Modelo (toneladas)	Rosca W	Longitud de rosca X
HCR50	M130 x 2	1.18
HCR100	M175 x 3	1.81
HCR150	M215 x 3	2.17
HCR200	M250 x 3	2.48
HCR250	M280 x 3	2.52
HCR300*	M305 x 3	2.87

Roscas del collar estándar en modelos hasta 250 ton. Roscas del collar opcionales en modelos de 300T y superiores. Para ordenar cilindros con roscas de collar opcionales agregar el sufijo "E002" al número de modelo. Ejemplo: **HCR3006E002**. La longitud de rosca del collar está diseñada para toda la capacidad nominal del cilindro.

Orificios de montaje en la base (pulg)					
Model / Capacity (toneladas)	Circulo de Pernos U	Rosca V	Profundidad mín. de rosca Z	Cantidad de orificios	Ángulo desde el acoplador
HCR50	4.13	M12 x 1,75	0.87	2	90°
HCR100	5.91	M12 x 1,75	0.87	2	90°
HCR150	7.28	M12 x 1,75	0.87	2	90°
HCR200	8.46	M12 x 1,75	0.87	3	60°
HCR250	9.65	M12 x 1,75	0.87	3	60°
HCR300	10.24	M16 x 2	0.98	3	60°

## Cilindros de doble acción, serie HCR

- Avance y retracción rápidos
- Diseñados para soportar hasta 10% de su máxima capacidad en carga lateral <sup>1)</sup>
- Superficie endurecida que resiste carga lateral y desgaste cíclico
- Con protección interior y exterior contra los elementos
- Cojinetes reemplazables superior e inferior que rodean al émbolo del cilindro para proporcionar soporte a lo largo de la carrera
- Argollas de elevación certificadas, orificios para montaje en la base y roscas en el collar
- Roscas del collar estándar en modelos hasta 250 ton. Roscas del collar opcionales en modelos de 300T y superiores.

### TABLA DE SELECCIÓN MODELOS HCR 50 - 300 TONELADAS

Para modelos de 400 - 1000 toneladas, consulte las páginas 54-55.

Para conocer todas las características del producto, consulte las páginas 44-45.

Capacidad máxima del cilindro (ton)	Carrera (pulg)	Número del modelo	Capacidad máxima del cilindro a 10,150 psi (ton)	Área efectiva del cilindro (pulg <sup>2</sup> )	Volumen de aceite (pulg <sup>3</sup> )		Altura retraído A (pulg)
					Avance	Retracción	
50	1.97	HCR502	62	12.17	23.96	12.22	7.20
	3.94	HCR504			47.93	24.44	9.17
	5.91	HCR506 <sup>1)</sup>			71.89	36.66	11.14
	7.87	HCR508			95.86	48.89	13.62
	9.84	HCR5010			119.82	61.11	15.59
100	1.97	HCR1002	113	22.19	43.67	22.05	7.95
	3.94	HCR1004			87.35	44.09	9.92
	5.91	HCR1006			131.02	66.14	11.89
	7.87	HCR1008			174.70	88.19	14.92
	9.84	HCR10010			218.37	110.23	16.89
150	1.97	HCR1502	168	33.14	65.24	30.73	8.66
	3.94	HCR1504			130.48	61.47	10.63
	5.91	HCR1506			195.73	92.20	12.60
	7.87	HCR1508			260.97	122.94	15.63
	9.84	HCR15010			326.21	153.67	17.60
200	1.97	HCR2002	223	43.95	86.51	39.54	9.09
	3.94	HCR2004			173.02	79.08	11.06
	5.91	HCR2006			259.53	118.62	13.03
	7.87	HCR2008			346.04	158.16	16.06
	9.84	HCR20010			432.55	197.70	18.03
250	1.97	HCR2502	286	56.27	110.77	41.52	9.49
	3.94	HCR2504			221.55	83.04	11.46
	5.91	HCR2506			332.32	124.55	13.43
	7.87	HCR2508			443.09	166.07	16.97
	9.84	HCR25010			553.87	207.59	18.94
300	1.97	HCR3002	341	67.23	664.64	249.11	20.91
	3.94	HCR3004			132.34	36.49	11.65
	5.91	HCR3006			264.68	72.97	13.62
	7.87	HCR3008			397.02	109.46	15.59
	9.84	HCR30010			529.36	145.94	17.56
300	11.81	HCR30012	341	67.23	661.71	182.43	19.53
	11.81	HCR30012			794.05	218.91	21.50

<sup>1)</sup> HCR506 y HCR5012: capacidad máxima de carga lateral 7%.

# Cilindros de doble acción y alto tonelaje

Capacidad:  
**50 - 300 toneladas**

Carrera:  
**1.97 - 11.81 pulgadas**

Presión de operación máxima:  
**10,150 psi**

Serie  
**HCR**

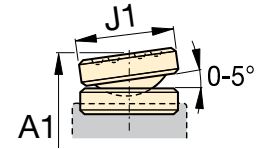

Silleta de inclinación serie CATS

	Altura extendido B (pulg)	Diámetro exterior D (pulg)	Diámetro interno del cilindro E (pulg)	Diámetro del émbolo F (pulg)	Base a conexión de entrada de avance H (pulg)	Parte superior a conexión I (pulg)	Diámetro de la silleta J (pulg)	Extensión de la silleta desde el émbolo K (pulg)	Volumen de aceite retracción (pulg³)	Peso (lbs)	Número de modelo	Silletas inclinables opcionales		
												Diám. J1 (pulg)	Altura colap.* A1 (pulg)	Número de modelo
	9.17	5.12	3.94	2.76	1.50	1.77	1.97	0.12	12.22	37	HCR502	2.80	7.75	CATS50
	13.11								24.44	46	HCR504		9.72	
	17.05								36.66	54	HCR506 <sup>1)</sup>		11.69	
	21.50					48.89			68	HCR508	14.17			
	25.43					61.11			76	HCR5010	16.14			
	29.37					73.33			84	HCR5012 <sup>1)</sup>	18.11			
	9.92	6.89	5.31	3.74	1.50	2.56	2.95	0.12	22.05	74	HCR1002	2.80	8.35	CATS101
	13.86								44.09	90	HCR1004		10.31	
	17.80								66.14	105	HCR1006		12.28	
	22.80					88.19			131	HCR1008	15.31			
	26.73					110.23			146	HCR10010	17.28			
	30.67					132.28			161	HCR10012	19.25			
	10.63	8.46	6.50	4.72	1.61	2.76	3.70	0.12	30.73	124	HCR1502	3.82	9.41	CATS150
	14.57								61.47	148	HCR1504		11.38	
	18.50								92.20	172	HCR1506		13.35	
	23.50					122.94			209	HCR1508	16.38			
	27.44					153.67			233	HCR15010	18.35			
	31.38					184.40			257	HCR15012	20.31			
	11.06	9.84	7.48	5.51	1.85	3.11	4.45	0.12	39.54	179	HCR2002	4.96	9.80	CATS200
	15.00								79.08	212	HCR2004		11.77	
	18.94								118.62	244	HCR2006		13.74	
	23.94					158.16			306	HCR2008	16.77			
	27.87					197.70			338	HCR20010	18.74			
	31.81					237.24			371	HCR20012	20.71			
	11.46	11.02	8.46	6.69	2.09	3.11	5.51	0.16	41.52	236	HCR2502	6.89	11.00	CATS300
	15.39								83.04	279	HCR2504		13.00	
	19.33								124.55	322	HCR2506		14.96	
	24.84					166.07			407	HCR2508	18.50			
	28.78					207.59			457	HCR25010	20.47			
	32.72					249.11			500	HCR25012	22.44			
	13.62	12.01	9.25	7.87	2.28	3.98	5.51	0.16	36.49	350	HCR3002	6.89	13.19	CATS300
	17.56								72.97	404	HCR3004		15.16	
	21.50								109.46	458	HCR3006		17.13	
	25.43								145.94	512	HCR3008		19.00	
	29.37								182.43	566	HCR30010		21.00	
	33.31								218.91	620	HCR30012		23.00	

\* A1 = Altura retraída incluyendo la silleta inclinable Serie CATS.

## Cilindros de doble acción, serie HCR

- Avance y retracción rápidos
- Diseñados para soportar hasta 10% de su máxima capacidad en carga lateral
- Superficie endurecida que resiste carga lateral y desgaste cíclico
- Con protección interior y exterior contra los elementos
- Cojinetes reemplazables superior e inferior que rodean al émbolo del cilindro para proporcionar soporte a lo largo de la carrera
- Argollas de elevación certificadas, orificios para montaje en la base y roscas en el collar
- Roscas del collar opcionales en modelos de 300T y superiores.

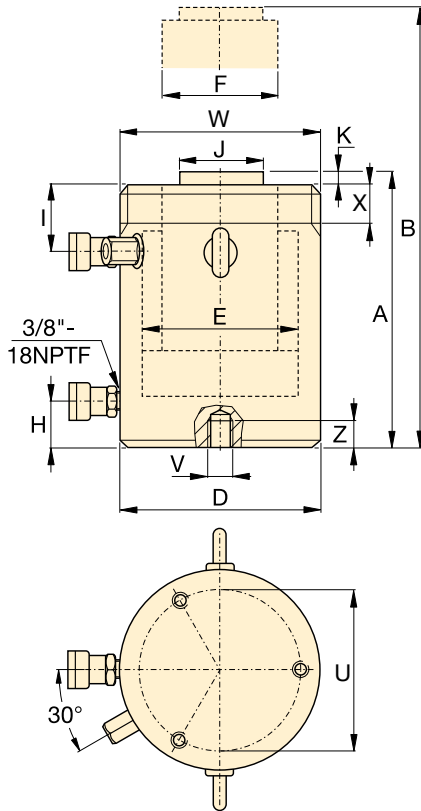

**TABLA DE SELECCIÓN MODELOS HCR 400 – 1000 TONELADAS**

Para modelos de 50 - 300 toneladas, consulte las páginas 52-53.

Para conocer todas las características del producto, consulte las páginas 44-45.

Capacidad máxima del cilindro (ton)	Carrera (pulg)	Número del modelo	Capacidad máxima del cilindro a 10,150 psi (ton)	Área efectiva del cilindro (pulg <sup>2</sup> )	Volumen de aceite (pulg <sup>3</sup> )		Altura retraído A (pulg)
					Avance	Retracción	
400	1.97	HCR4002	450	88.75	174.70	58.71	12.64
	3.94	HCR4004			349.39	117.42	14.61
	5.91	HCR4006			524.09	176.14	16.57
	7.87	HCR4008			698.79	234.85	18.54
	9.84	HCR40010			873.49	293.56	20.51
	11.81	HCR40012			1048.18	352.27	22.48
500	1.97	HCR5002	575	113.25	222.92	73.15	13.54
	3.94	HCR5004			445.85	146.30	15.51
	5.91	HCR5006			668.77	219.45	17.48
	7.87	HCR5008			891.70	292.60	19.45
	9.84	HCR50010			1114.62	365.75	21.42
	11.81	HCR50012			1337.55	438.90	23.39
600	1.97	HCR6002	673	132.57	260.97	86.27	13.86
	3.94	HCR6004			521.94	172.54	15.83
	5.91	HCR6006			782.90	258.81	17.80
	7.87	HCR6008			1043.87	345.08	19.76
	9.84	HCR60010			1304.84	431.35	21.73
	11.81	HCR60012			1565.81	517.62	23.70
800	1.97	HCR8002	916	180.44	355.21	109.81	15.91
	3.94	HCR8004			710.41	219.63	17.87
	5.91	HCR8006			1065.62	329.44	19.84
	7.87	HCR8008			1420.82	439.26	21.81
	9.84	HCR80010			1776.03	549.07	23.78
	11.81	HCR80012			2131.24	658.89	25.75
1000	1.97	HCR10002	1196	235.68	463.94	186.92	17.40
	3.94	HCR10004			927.88	373.84	19.37
	5.91	HCR10006			1391.83	560.76	21.34
	7.87	HCR10008			1855.77	747.68	23.31
	9.84	HCR100010			2319.71	934.59	25.28
	11.81	HCR100012			2783.65	1121.51	27.24

Rosca del collar (pulg)		
Número de Modelo (toneladas)	Rosca W	Longitud de rosca X
HCR400	M350 x 3	3.27
HCR500	M400 x 4	3.54
HCR600	M430 x 4	3.94
HCR800	M505 x 5	4.80
HCR1000	M570 x 5	5.39

Roscas del collar opcionales en modelos de 300T y superiores. Para ordenar cilindros con roscas de collar opcionales agregar el sufijo "E002" al número de modelo. Ejemplo: **HCR4006E002**. La longitud de rosca del collar está diseñada para toda la capacidad nominal del cilindro.

Orificios de montaje en la base (pulg)					
Model / Capacity (toneladas)	Circulo de Pernos U	Rosca V	Profundidad mín. de rosca Z	Cantidad de orificios	Ángulo desde el acoplador
HCR400	11.81	M16 x 2	0.98	3	60°
HCR500	13.39	M24 x 3	1.42	3	60°
HCR600	14.57	M24 x 3	1.42	3	60°
HCR800	17.32	M24 x 3	1.42	3	60°
HCR1000	19.69	M24 x 3	1.42	3	60°

# Cilindros de doble acción y alto tonelaje



▲ El super levante y botadura al agua de un sistema flotante de producción de petróleo de 43,000 toneladas en Malasia para el yacimiento mar afuera Gumusut-Kakap ha establecido altos estándares en cuanto a seguridad mediante el uso de sofisticados sistemas hidráulicos síncronos de la serie EVO para elevar, equilibrar, pesar y botar al agua fácilmente gigantescas estructuras de recursos.

Serie  
**HCR**



Capacidad:

**400 - 1000 toneladas**

Carrera:

**1.97 - 11.81 pulgadas**

Presión de operación máxima:

**10,150 psi**

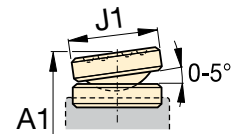

Silleta de inclinación serie CATS

Altura extendido B (pulg)	Diámetro exterior D (pulg)	Diámetro interno del cilindro E (pulg)	Diámetro del émbolo F (pulg)	Base a conexión de entrada de avance H (pulg)	Parte superior a conexión I (pulg)	Diámetro de la silleta J (pulg)	Extensión de la silleta desde el émbolo K (pulg)	Volumen de aceite retracción (pulg <sup>3</sup> )	Peso (lbs)	Número de modelo	Silletas inclinables opcionales		
											Diám. J1 (pulg)	Altura colap.* A1 (pulg)	Número de modelo
14.61	13.78	10.63	8.66	2.91	4.37	6.26	0.16	58.71	501	HCR4002	8.27	14.53	CATS400
18.54								117.42	570	HCR4004		16.50	
22.48								176.14	638	HCR4006		18.46	
26.42								234.85	707	HCR4008		20.43	
30.35								293.56	775	HCR40010		22.40	
34.29								352.27	843	HCR40012		24.37	
15.51	15.75	12.01	9.84	3.11	4.76	7.05	0.16	73.15	706	HCR5002	9.06	15.43	CATS500
19.45								146.30	797	HCR5004		17.40	
23.39								219.45	887	HCR5006		19.37	
27.32								292.60	977	HCR5008		21.34	
31.26								365.75	1,067	HCR50010		23.31	
35.20								438.90	1,158	HCR50012		25.28	
15.83	16.93	12.99	10.63	3.35	4.76	7.64	0.16	86.27	836	HCR6002	9.84	15.94	CATS600
19.76								172.54	940	HCR6004		17.91	
23.70								258.81	1,044	HCR6006		19.88	
27.64								345.08	1,148	HCR6008		21.85	
31.57								431.35	1,252	HCR60010		23.82	
35.51								517.62	1,356	HCR60012		25.79	
17.87	19.88	15.16	12.60	3.94	5.63	8.82	0.16	109.81	1,340	HCR8002	10.83	18.15	CATS800
21.81								219.63	1,485	HCR8004		20.12	
25.75								329.44	1,631	HCR8006		22.00	
29.69								439.26	1,777	HCR8008		24.00	
33.62								549.07	1,922	HCR80010		26.00	
37.56								658.89	2,068	HCR80012		28.00	
19.37	22.44	17.32	13.39	4.49	6.02	9.80	0.16	186.92	1,858	HCR10002	11.81	20.43	CATS1000
23.31								373.84	2,031	HCR10004		22.40	
27.24								560.76	2,205	HCR10006		24.37	
31.18								747.68	2,379	HCR10008		26.34	
35.12								934.59	2,552	HCR100010		28.31	
39.06								1121.51	2,726	HCR100012		30.28	

\* A1 = Altura retraída incluyendo la silleta inclinable Serie CATS.