

FA1TM

FLANGE
ALIGNMENT
TOOL



CONTENTS

1. INTRODUCTION
2. TOOL SAFETY
 - 2.1 GENERAL SAFETY
 - 2.2 PERSONNEL COMPETENCY
 - 2.3 DISCLAIMER
 - 2.4 DEFINITION OF TERMS
 - 2.5 HAZARDS
3. FLANGE MISALIGNMENT DETERMINATION PROCEDURE
 - 3.1 LATERAL MISALIGNMENT
4. FA1TM MECHANICAL FLANGE ALIGNMENT TOOL
 - 4.1 TOOL CAPABILITIES
 - 4.2 RANGE OF APPLICATION
 - 4.3 TOOL FUNCTION
 - 4.4 KIT CONTENTS
 - 4.5 TOOL DIMENSIONS
 - 4.6 TOOL MAINTENANCE
5. RANGE OF APPLICATION
 - 5.1 BS10, API6BX, API6B WELD NECK FLANGE TABLES
 - 5.2 ASME B16.5, ASME B16.47, DIN WELD NECK FLANGE TABLES
 - 5.3 SPO FLANGE TABLE
6. TROUBLESHOOTING
 - 6.1 FA1TM TROUBLESHOOTING
7. REGULATORY INFORMATION
 - 7.1 REGISTERED HEAD OFFICE
8. PARTS LISTS & SERVICE KITS

17/10/2019

1.

INTRODUCTION

The Equalizer FA1TM TOOL is an aid of use in normal maintenance and installation procedures to enable the realignment of misaligned flanges within respective working capacities. For example, the tool can be used to assist in the replacement of ring and other types of flange joint.

The use of these instructions will promote safe use, and maximise the service life of the tools.

It is essential that the user familiarises themselves with the contents of this manual prior to using the tool.

This manual contains information for the following tools:

- FA1TM Flange Alignment Tool

2.

SAFETY INFORMATION

2.1

GENERAL SAFETY

These instructions cover the safe operation and maintenance of THE EQUALIZER **FA1TM** FLANGE ALIGNMENT tools. The use of these tools should be as part of a broader task-based risk assessment, which should be carried out by the operation supervisor or other competent person.

Failure to comply with the safety information contained within this manual could result in personal injury or equipment damage. Read all instructions, warnings and cautions carefully, and follow all safety precautions.

The safety of the operator, any assisting personnel and the general public is of paramount importance. Always work in accordance with applicable national, local, site & company-wide safety procedures.

2.2

PERSONNEL COMPETENCY

Only personnel deemed competent in the use of mechanical and hydraulic equipment should use these tools.

2.3

DISCLAIMER

Equalizer cannot be held responsible for injury or damage resulting from unsafe product use, lack of maintenance or incorrect product and/or system operation. If in doubt as to the safety precautions and applications, contact Equalizer using the contact details at the back of this manual.

2.4

DEFINITION OF TERMS

A **CAUTION** is used to indicate correct operating or maintenance procedures and practices to prevent damage to, or destruction of equipment or other property.

A **WARNING** indicates a potential danger that requires correct procedures or practices to avoid personal injury.

A **DANGER** is only used when your action or lack of action may cause serious injury or even death.



DO: an illustration showing how the tool should be used.



DON'T: an illustration showing an incorrect way to use a tool.

2.5

HAZARDS



WARNING: ensure all hydraulic components are rated to a safe working pressure of 700 bar (10 000 psi).



WARNING: Do not overload equipment. The risk of hydraulic overloading can be minimised by using the Equalizer Hand Pump, which has a factory-set safety valve preventing the safe working pressure being exceeded.

If alternative hydraulic pumps are used, ensure that there are adequate systems to limit the the working pressure to 700 bar (10,000 psi).



CAUTION: ensure components are protected from external sources of damage, such as excessive heat, flame, moving machine parts, sharp edges and corrosive chemicals.



CAUTION: Take care to avoid sharp bends and kinks in hydraulic hoses. Bends and kinks can cause severe back-up pressure and cause hose failure. Protect hoses from dropped objects; a sharp impact may cause internal damage to hose wire strands. Protect hoses from crush risks, such as heavy objects or vehicles; crush damage can cause hose failure.



WARNING: Applying pressure to a damaged hose may cause it to rupture.



WARNING: Immediately replace worn or damaged parts. Use only genuine Equalizer parts from approved distributors or service centres. Equalizer parts have been engineered and manufactured to be fit-for-purpose.



DANGER: To minimise risk of personal injury keep hands and feet away from the tool and workpiece during operation.



WARNING: Always wear suitable clothing and Personal Protective Equipment (PPE). Do not handle pressurised hoses; escaping oil under pressure can penetrate the skin, causing serious injury. Seek medical attention immediately if oil penetration is suspected.



WARNING: Only pressurize complete and fully connected hydraulic systems. Do not pressurize systems that contain unconnected couplers.



CAUTION: Do not lift hydraulic equipment by the hoses or couplers. Use only the designated carrying handles.



CAUTION: Lubricate tools as directed in this manual prior to operation. Use only approved lubricants of high quality, following the lubricant manufacturers instructions.



CAUTION: Only use the designated anchor point for fixing the lanyard. Do not attach the lanyard to the plastic handle.



DANGER: Care should be taken when using the lanyard to avoid entanglement with body parts.



The vibration total value to which this tool is subjected does not exceed 2.5 m/s².

3.

FLANGE MISALIGNMENT DETERMINATION PROCEDURE

The tool being used must not be attached to a flanged joint prior to the misalignment procedure being carried out.

3.1

LATERAL MISALIGNMENT

1. Loosen and remove every second bolt around the flange. Continue with this until misalignment occurs.

A flanged joint, once broken down, may spring out of alignment at any point or in any direction around its circumference. Misalignment may not occur until only a few bolts remain.

2. At this point the direction of any misalignment should become obvious. The alignment tool being used should be attached at the maximum point of misalignment (point A or B in the examples shown below).

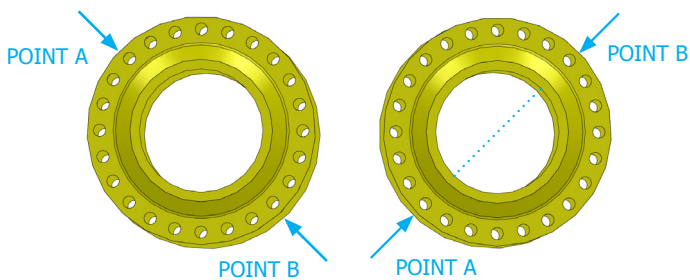

4.

FA1TM

MECHANICAL FLANGE ALIGNMENT TOOL

The FA1TM Flange Alignment Tool uses mechanical torque to advance the screw bolt and align the flanges.

4.1 TOOL CAPABILITIES

Maximum aligning force of tool = 1 T (10 kN)

4.2 RANGE OF APPLICATION

MINIMUM AND MAXIMUM FLANGE SIZES

Dimension A: must be between 14 mm and 82 mm (0.55" and 3.23").

Dimension B: bolt-hole diameter must be 16 mm (0.63") or greater

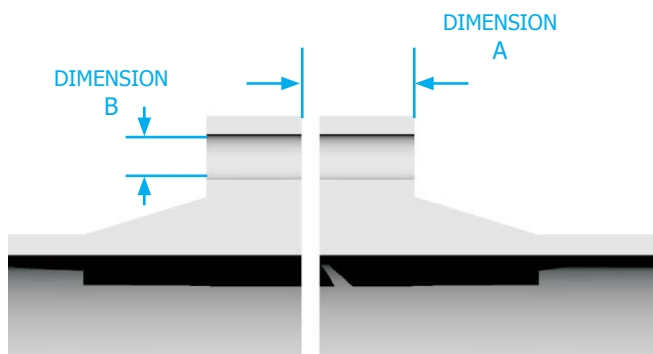

4.3 FA1TM TOOL FUNCTION

FA1TM GENERAL GUIDANCE

1. The FA1TM is secured to the lower of the two flanges by fully inserting the lift hool into the bolt-hole at the point of greatest misalignment.
2. The drop leg release knob is slackened and the drop leg is adjusted down to the pipe while the tool is held level in the bolt-hole.
3. The drop leg release knob is then tightened until firm.
4. The strap and buckle are attached to the drop leg and around the pipe for added security.
5. The crank handle is then turned clockwise until the driven wedge comes into contact with the circumference of the opposite flange.

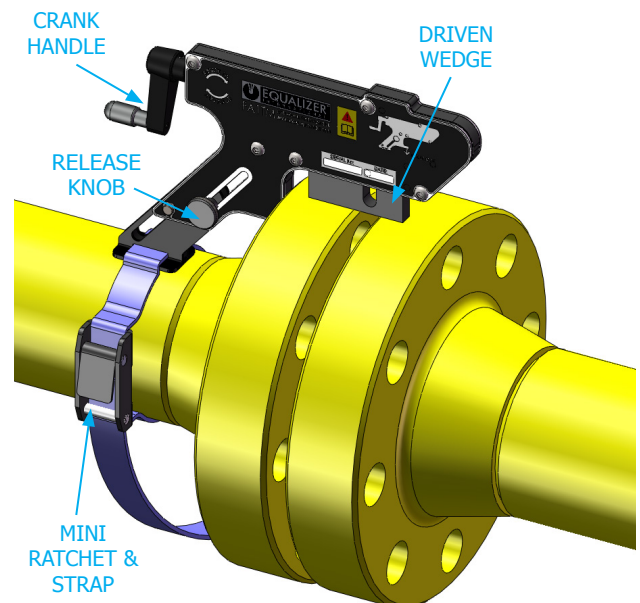

ACTUATING THE FA1TM

Carry out the Flange Misalignment Determination Procedure (see Section 3) to determine the points of maximum misalignment.

In this example the points of maximum misalignment are the top and bottom of the joint.

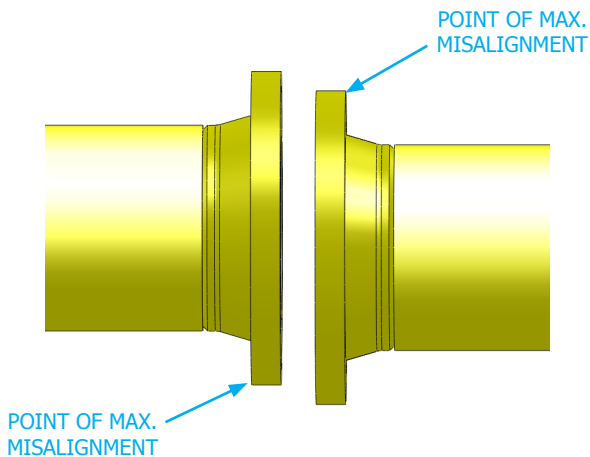

Guide the lift hook into the bolt-hole at the point of maximum misalignment.

Adjust the drop leg down onto the pipe by slackening the release knob in an anticlockwise direction.

The tool should be held up level within the bolt-hole during adjustment. NB: The tool must be parallel to pipe during operation.

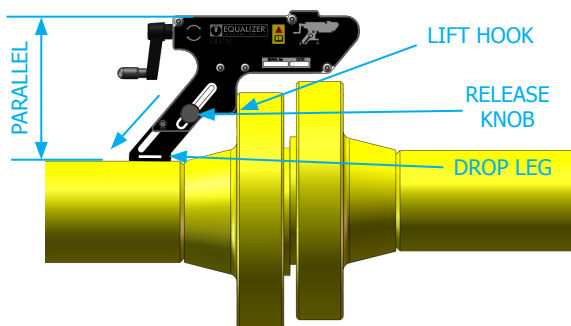

The drop leg release knob is then tightened until firm.

Rotate the crank handle clockwise until the driven wedge makes contact with the opposite flange.

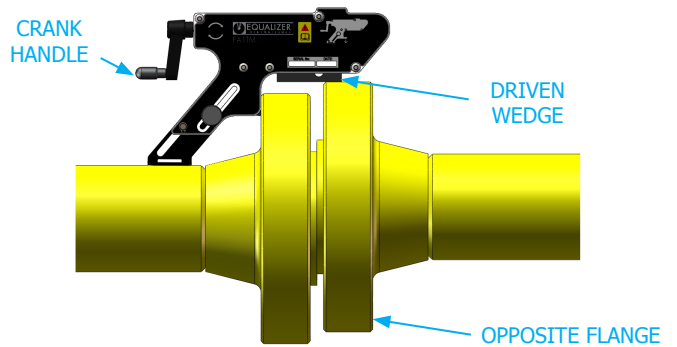

Thread the strap through the aperture on the base of the drop leg as shown.

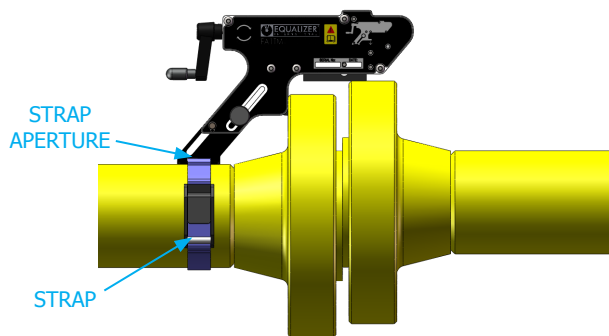

Feed the open end of the strap through the buckle mechanism as shown.

Close the clasp to secure strap.

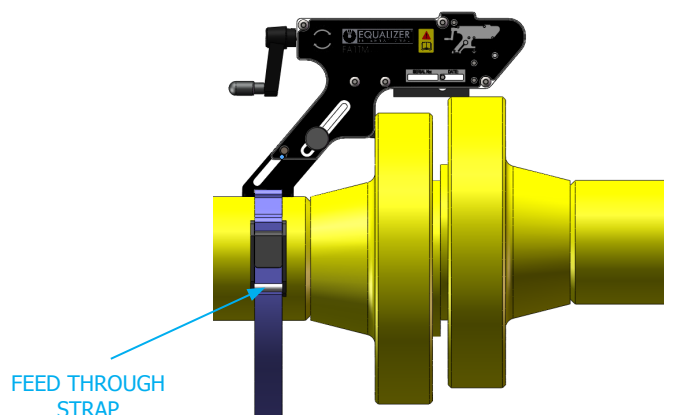

Now that everything is secured, rotate the handle clockwise to apply pressure to the circumference of the opposite flange & bring the flange joint in alignment.

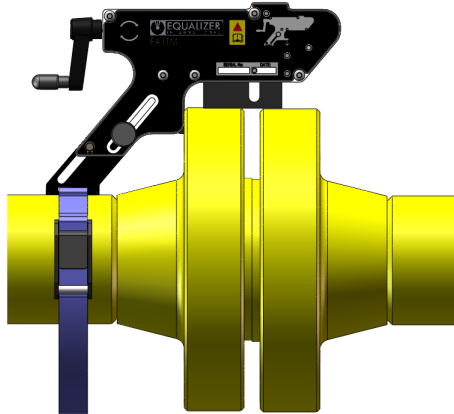

WARNING: Do not exceed hand pressure on the crank handle

Once in alignment the bolts may be inserted and tightened. After replacing all of the bolts (apart from the bolt which will go into the bolt-hole in which the FA1TM is located) remove the tool by reversing the previous steps. Insert the last bolt and tighten.



WARNING: Care should be taken not to drop any of the component parts when removing them from the flange joint. This action will prevent injuries to either the operator's lower limbs, or to passers-by.

4.4

FA1TM KIT CONTENTS

Product Code: FA1TMSTD

- 1 x FA1TM Tool
- 1 x Mini Ratchet Strap
- 1 x Instruction Manual



Box Dimensions:

180.0mm x 330.0mm x 220.0mm
(7.1" x 13.0" x 8.7")

Tool only Weight: 2.1 kg (4.63 lb)
Gross Kit Weight: 2.3 kg (5.07 lb)

4.5 FA1TM TOOL DIMENSIONS

MINIMUM EXTENSION

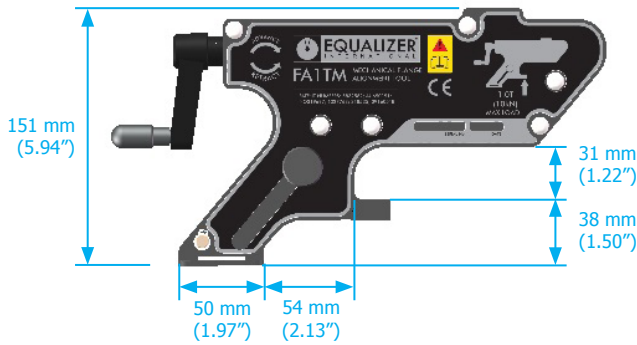

MAXIMUM EXTENSION

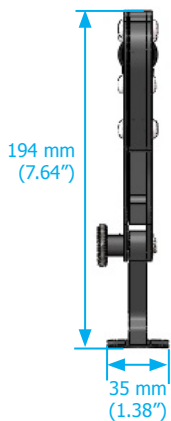
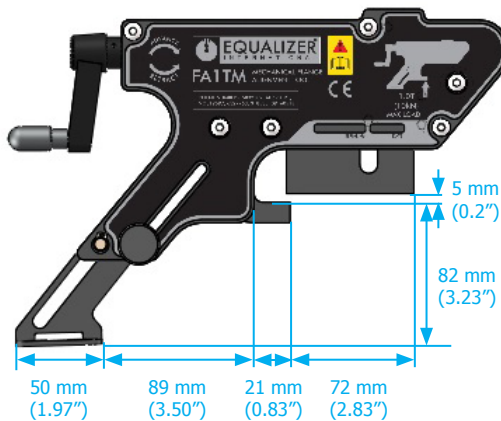

4.6 FA1TM TOOL MAINTENANCE

INSPECTION

A thorough inspection should be carried out prior to usage, storage or transportation to ensure the completeness and condition of the tool.

Inspection should include:

- visual inspection of the outer parts of the tool, checking for obvious damage, degradation or missing parts.

Cleaning and servicing should be undertaken as required prior to the tool being used, stored or transported.

CLEANING

To lightly clean the tool, wipe gently with a damp cloth.

If more thorough cleaning is required (for example following immersion in water) carry out the following cleaning procedure:

- strip the tool down, observing the schematics in section 8
- clean the components using detergent, following the manufacturer's guidelines
- rinse the components to remove traces of detergent
- dry the component thoroughly

Inspect, service and lubricate the tool immediately after the cleaning process.

SERVICING

Replace missing, worn or damaged parts. Use only genuine Equalizer parts from approved distributors or service centres. Equalizer parts have been engineered and manufactured to be fit for purpose.

Grease all moving parts by following the Lubrication Procedure prior to usage, storage or transportation.

Ensure wedges, pins and legs remain grit free and that parts move freely.

Secure the tool upright on a bench.

Using a small flat screwdriver, lever out one circlip and unscrew 6 x 6mm hex screws.

Remove cover plate and remove any dirt or corrosion from moving parts.

Inspect components for wear and damage, replace if necessary! If there's no damage present, then they can be greased and re-assembled by reversing the previous steps.

Recommended grease –

Rocol Sapphire Hi-Load or equivalent good quality hi load bearing grease.

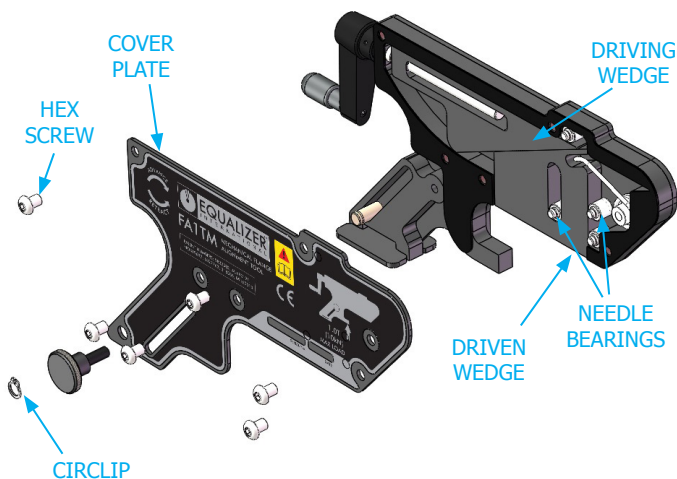

STORAGE AND TRANSPORTATION

Equalizer tools should be stored in a cool, dry place. Tools should always be cleaned, serviced and lubricated prior to storage. Ensure that tools are stored in their designated packing cases.

LONG-TERM STORAGE - MAINTENANCE PLAN

1. Rub components down with a dry cloth to remove moisture.
2. Coat EVERY surface and contact point with a corrosion inhibitor. Where necessary, coat inside and outside of component
3. Nuts and threads must also be coated with a corrosion inhibitor.
4. Once surfaces have been coated, seal individual components in clear plastic bags or clear vacuum bags or clear shrink wrap.
NOTE: bags/shrink wrap must be clear for visibility. Take care when using shrink wrap that the tool is/ components are still easy to see.
5. Remove all or, where not vacuum sealed, as much air from bags as possible.
6. Once bags have been closed and sealed DO NOT re-open. Any visual inspections must be done with closed and sealed bags. If bags are opened the components will have to be dried, re-coated and re-sealed in bags/ shrink wrap.
7. Replace silica gel (100g) EVERY TIME the case is opened.
NOTE: depending on moisture content of air, silica gel should be changed weekly.
8. Visually inspect kits after 30-days and every 30-days thereafter. Remember to replace silica gel before closing case.

5 RANGE OF APPLICATION

5.1 BS10 FLANGE RANGE OF APPLICATION

CLASS A	CLASS D	CLASS E	CLASS F	CLASS H	CLASS J	CLASS K	CLASS R	CLASS S	CLASS T
NPS 3 1/2"	4"	1 1/4"	1 1/4"	1 1/4"	1 1/4"	1"	1"	1/2"	1/2"
4"	5"	1 1/2"	1 1/2"	1 1/2"	1 1/2"	1 1/4"	1 1/4"	3/4"	3/4"
5"	6"	2"	2"	2"	2"	1 1/2"	1 1/2"	1"	1"
6"	7"	2 1/2"	2 1/2"	2 1/2"	2 1/2"	2"	2"	1 1/4"	1 1/4"
7"	8"	3"	3"	3"	3"	2 1/2"	2 1/2"	1 1/2"	1 1/2"
8"	9"	3 1/2"	3 1/2"	3 1/2"	3 1/2"	3"	3"	2"	2"
9"	10"	4"	4"	4"	4"	3 1/2"	3 1/2"	2 1/2"	2 1/2"
10"	12"	5"	5"	5"	5"	4"	4"	3"	3"
12"	13"	6"	6"	6"	6"	5"	5"	3 1/2"	3 1/2"
13"	14"	7"	7"	7"	7"	6"	6"	4"	4"
14"	15"	8"	8"	8"	8"	7"	7"	4 1/2"	4 1/2"
15"	16"	9"	9"	9"	9"	8"	8"	5"	5"
16"	17"	10"	10"	10"	10"	9"	9"	6"	6"
17"	18"	12"	12"	12"	12"	10"	10"	7"	7"
18"	19"	13"	13"	13"	13"	11"	11"	8"	8"
19"	20"	14"	14"	14"	14"	12"	12"	9"	9"
20"	21"	15"	15"	15"	15"	13"	13"	10"	10"
21"	22"	16"	16"	16"	16"	14"	14"	11"	11"
22"	23"	17"	17"	17"	17"	15"	15"	12"	12"
23"	24"	18"	18"	18"	18"	16"	16"	13"	13"
24"	26"	19"	19"	19"	19"	17"	17"	14"	14"
26"	27"	20"	20"	20"	20"	18"	18"	15"	15"
27"	29"	21"	21"	21"	21"	19"	19"	16"	16"
29"	30"	22"	22"	22"	22"	20"	20"		
30"	33"	23"	23"	23"	23"				
33"	35"	24"	24"	24"	24"				
35"	36"	25"	25"	25"	25"				
36"	39"	26"	26"	26"	26"				
39"	42"	27"	27"	27"	27"				
42"	45"	28"	28"	28"	28"				
45"	48"	29"	29"	29"	29"				
48"	54"	30"	30"	30"	30"				
54"	60"	31"	31"	31"	31"				
60"	66"	32"	32"	32"	32"				
66"	72"	33"	33"	33"	33"				
72"	78"	34"	34"	34"	34"				
78"	84"	35"	35"	35"	35"				
84"	96"	36"	36"	36"	36"				
96"	108"	37"	37"	37"	37"				
108"	120"	38"	38"	38"	38"				

SUITABLE FOR FA1TM TOOL
SUITABLE FOR FA4TM TOOL
SUITABLE FOR FA9TE TOOL
NOT SUITABLE FOR TOOLS

API6B WELD NECK FLANGE RANGE OF APPLICATION

CLASS 10K	CLASS 15K	CLASS 20K
NPS 1 1/2"	1 1/2"	1 1/2"
2"	2"	2"
2 1/2"	2 1/2"	2 1/2"
3"	3"	3"
3 1/2"	3 1/2"	3 1/2"
4"	4"	4"
4 1/2"	4 1/2"	4 1/2"
5"	5"	5"
5 1/2"	5 1/2"	5 1/2"
6"	6"	6"
6 1/2"	6 1/2"	6 1/2"
7"	7"	7"
7 1/2"	7 1/2"	7 1/2"
8"	8"	8"
8 1/2"	8 1/2"	8 1/2"
9"	9"	9"
9 1/2"	9 1/2"	9 1/2"
10"	10"	10"
10 1/2"	10 1/2"	10 1/2"
11"	11"	11"
11 1/2"	11 1/2"	11 1/2"
12"	12"	12"
12 1/2"	12 1/2"	12 1/2"
13"	13"	13"
13 1/2"	13 1/2"	13 1/2"
14"	14"	14"
14 1/2"	14 1/2"	14 1/2"
15"	15"	15"
15 1/2"	15 1/2"	15 1/2"
16"	16"	16"
16 1/2"	16 1/2"	16 1/2"
17"	17"	17"
17 1/2"	17 1/2"	17 1/2"
18"	18"	18"
18 1/2"	18 1/2"	18 1/2"
19"	19"	19"
19 1/2"	19 1/2"	19 1/2"
20"	20"	20"

API6B WELD NECK FLANGE RANGE OF APPLICATION

CLASS 2K	CLASS 3K	CLASS 5K
NPS 2 1/2"	2 1/2"	2 1/2"
3"	3"	3"
3 1/2"	3 1/2"	3 1/2"
4"	4"	4"
4 1/2"	4 1/2"	4 1/2"
5"	5"	5"
5 1/2"	5 1/2"	5 1/2"
6"	6"	6"
6 1/2"	6 1/2"	6 1/2"
7"	7"	7"
7 1/2"	7 1/2"	7 1/2"
8"	8"	8"
8 1/2"	8 1/2"	8 1/2"
9"	9"	9"
9 1/2"	9 1/2"	9 1/2"
10"	10"	10"
10 1/2"	10 1/2"	10 1/2"
11"	11"	11"
11 1/2"	11 1/2"	11 1/2"
12"	12"	12"
12 1/2"	12 1/2"	12 1/2"
13"	13"	13"
13 1/2"	13 1/2"	13 1/2"
14"	14"	14"
14 1/2"	14 1/2"	14 1/2"
15"	15"	15"
15 1/2"	15 1/2"	15 1/2"
16"	16"	16"
16 1/2"	16 1/2"	16 1/2"
17"	17"	17"
17 1/2"	17 1/2"	17 1/2"
18"	18"	18"
18 1/2"	18 1/2"	18 1/2"
19"	19"	19"
19 1/2"	19 1/2"	19 1/2"
20"	20"	20"

5.2 ASME B16.5 FLANGE RANGE OF APPLICATION

CLASS 150	NPS	3/4"	1"	1 1/4"	1 1/2"	2"	2 1/2"	3"	3 1/2"	4"	5"	6"	8"	10"	12"	14"	16"	18"	20"	24"
	TOOL							FA1TM												FA4TM
CLASS 300	NPS	3/4"	1"	1 1/4"	1 1/2"	2"	2 1/2"	3"	3 1/2"	4"	5"	6"	8"	10"	12"	14"	16"	18"	20"	24"
	TOOL							FA1TM												FA4TM
CLASS 400	NPS	3/4"	1"	1 1/4"	1 1/2"	2"	2 1/2"	3"	3 1/2"	4"	5"	6"	8"	10"	12"	14"	16"	18"	20"	24"
	TOOL							FA1TM						FA4TM						FA9TE
CLASS 600	NPS	3/4"	1"	1 1/4"	1 1/2"	2"	2 1/2"	3"	3 1/2"	4"	5"	6"	8"	10"	12"	14"	16"	18"	20"	24"
	TOOL							FA1TM						FA4TM						FA9TE
CLASS 900	NPS	1/2"	3/4"	1"	1 1/4"	1 1/2"	2"	2 1/2"	3"	4"	5"	6"	8"	10"	12"	14"	16"	18"	20"	24"
	TOOL							FA1TM												FA9TE
CLASS 1500	NPS	1/2"	3/4"	1"	1 1/4"	1 1/2"	2"	2 1/2"	3"	4"	5"	6"	8"	10"	12"	14"	16"	18"	20"	24"
	TOOL							FA1TM												FA9TE
CLASS 2500	NPS	1/2"	3/4"	1"	1 1/4"	1 1/2"	2"	2 1/2"	3"	4"	5"	6"	8"	10"	12"	14"	16"	18"	20"	24"
	TOOL							FA1TM												FA9TE

ASME B16.47 FLANGE RANGE OF APPLICATION

CLASS 150	NPS	22"	26"	28"	30"	32"	34"	36"	38"	40"	42"	44"	46"	48"
	TOOL			FA4TM						FA9TE				
CLASS 300	NPS	22"	26"	28"	30"	32"	34"	36"	38"	40"	42"	44"	46"	48"
	TOOL			FA4TM						FA9TE				
CLASS 400	NPS	22"	26"	28"	30"	32"	34"	36"	38"	40"	42"	44"	46"	48"
	TOOL			FA4TM						FA9TE				
CLASS 600	NPS	22"	26"	28"	30"	32"	34"	36"	38"	40"	42"	44"	46"	48"
	TOOL			FA4TM						FA9TE				
CLASS 900	NPS	22"	26"	28"	30"	32"	34"	36"	38"	40"	42"	44"	46"	48"
	TOOL			FA9TE										

DIN WELD NECK FLANGE RANGE OF APPLICATION

CLASS PN16	NPS	1 1/2"	2"	2 1/2"	3"	4"	5"	6"	7"	8"	10"	12"	14"	16"	18"	20"	24"	28"	32"	36"	40"	48"	56"	72"	80"
	TOOL							FA1TM													FA4TM				
CLASS PN25	NPS	1/2"	3/4"	1"	1 1/4"	1 1/2"	2"	2 1/2"	3"	4"	5"	6"	7"	8"	10"	12"	14"	16"	18"	20"	24"	28"	32"	36"	40"
	TOOL																				FA1TM				
CLASS PN40	NPS	1 1/2"	2"	2 1/2"	3"	4"	5"	6"	7"	8"	10"	12"	14"	16"	18"	20"									
	TOOL																				FA1TM				
CLASS PN64	NPS	3/4"	1"	1 1/2"	2"	2 1/2"	3"	4"	5"	6"	7"	8"	10"	12"	14"	16"									
	TOOL																				FA1TM				
CLASS PN100	NPS	1/2"	3/4"	1"	1 1/2"	2"	2 1/2"	3"	4"	5"	6"	7"	8"	10"	12"	14"									
	TOOL																				FA1TM				
CLASS PN160	NPS	3/8"	1/2"	3/4"	1"	1 1/2"	2"	2 1/2"	3"	4"	5"	6"	7"	8"	10"	12"									
	TOOL																				FA1TM				

	SUITABLE FOR FA1TM TOOL
	SUITABLE FOR FA4TM TOOL
	SUITABLE FOR FA9TE TOOL
	NOT SUITABLE FOR TOOLS

5.3 SPO FLANGE RANGE OF APPLICATION

CLASS	2 1/2"		3"		3 1/2"		4"		5"		6"		8"		10"		12"		14"		16"		18"		20"		22"		24"		26"		28"		30"		32"		34"		36"		38"		40"		42"		44"		46"		48"	
CLASS 150	NPS	2 1/2"	3"	3 1/2"	4"	5"	6"	8"	10"	12"	14"	16"	18"	20"	22"	24"	26"	28"	30"	32"	34"	36"	38"	40"	42"	44"	46"	48"	FA1TM																									
	TOOL	FA1TM																																																				
CLASS 300	NPS	2 1/2"	3"	3 1/2"	4"	5"	6"	8"	10"	12"	14"	16"	18"	20"	22"	24"	26"	28"	30"	32"	34"	36"	38"	40"	42"	44"	46"	48"	FA1TM																									
	TOOL	FA1TM																																																				
CLASS 600	NPS	2 1/2"	3"	3 1/2"	4"	5"	6"	8"	10"	12"	14"	16"	18"	20"	22"	24"	26"	28"	30"	32"	34"	36"	38"	40"	42"	44"	46"	48"	FA4TM																									
	TOOL	FA4TM																																																				
CLASS 900	NPS	2 1/2"	3"	3 1/2"	4"	5"	6"	8"	10"	12"	14"	16"	18"	20"	22"	24"	26"	28"	30"	32"	34"	36"	38"	40"	42"	44"	46"	48"	FA9TE																									
	TOOL	FA9TE																																																				
CLASS 1500	NPS	2 1/2"	3"	3 1/2"	4"	5"	6"	8"	10"	12"	14"	16"	18"	20"	22"	24"	26"	28"	30"	32"	34"	36"	38"	40"	42"	44"	46"	48"	FA4TM																									
	TOOL	FA4TM																																																				
CLASS 2500	NPS	2 1/2"	3"	3 1/2"	4"	5"	6"	8"	10"	12"	14"	16"	18"	20"	22"	24"	FA9TE																																					
	TOOL	FA9TE																																																				
CLASS 5000	NPS	2 1/2"	3"	3 1/2"	4"	5"	6"	8"	10"	12"	14"	16"	18"	20"	22"	24"	FA9TE																																					
	TOOL	FA9TE																																																				
CLASS 7500	NPS	2 1/2"	3"	3 1/2"	4"	5"	6"	8"	10"	12"	14"	16"	18"	20"	22"	24"	FA9TE																																					
	TOOL	FA9TE																																																				
CLASS 10000	NPS	2 1/2"	3"	3 1/2"	4"	5"	6"	8"	10"	12"	14"	16"	18"	20"	22"	24"	FA4TM																																					
	TOOL	FA4TM																																																				
CLASS 15000	NPS	2 1/2"	3"	3 1/2"	4"	5"	6"	8"	10"	12"	14"	16"	18"	20"	22"	24"	FA9TE																																					
	TOOL	FA9TE																																																				

SUITABLE FOR FA1TM TOOL
SUITABLE FOR FA4TM TOOL
SUITABLE FOR FA9TE TOOL
NOT SUITABLE FOR TOOLS

6.

TROUBLESHOOTING

6.1

FA1TM TROUBLESHOOTING

THE TOOL IS ATTACHED AND APPEARS TO BE FUNCTIONING PROPERLY, BUT THE JOINT WILL NOT ALIGN

POSSIBLE CAUSE:

There may be something restricting the joint from aligning.

RECOMMENDED ACTION:

Check the area around the joint to establish if there is an obstruction to the joint.

POSSIBLE CAUSE:

The joint may require more than 1 T (10 kN) force to align.

RECOMMENDED ACTION:

If the joint requires more force than that of the 1 T (10 kN) tool, attach a second tool or another method of aligning should be adapted.

7.

REGULATORY INFORMATION

7.1

REGISTERED HEAD OFFICE

EQUALIZER INTERNATIONAL LTD.
Equalizer House
Claymore Drive
Aberdeen
Scotland
AB23 8GD

8.

PARTS LISTS & SERVICE KITS

FA1TM

ITEM	PART NO.	DESCRIPTION	QUANTITY
01	210200-01	BODY FRAME (MACHINED)	01
02	210300-01	DRIVEN WEDGE	01
03	210400-01	DRIVE SCREW AS.	01
04	210501-01	BASE PLATE (3mm)	01
05	UPON REQUEST	COVER PLATE (2mm)	01
06	210600-01	CRANK HANDLE	01
07	210800-01	TORSION SPRING	01
08	210900-01	NEEDLE BEARING	04
09	211100-01	BEARING SHAFT	04
10	211200-01	SPRING MANDREL	01
11	211300-01	M6X8 GR10.9 SCKT FL.BT.SCRW	12
12	211800-01	DROP LEG AS.	01
13	230203-01	M6 RELEASE KNOB	01
14	211900-01	LEG PIN 8mm	01
15	212000-01	SPRING RING 8mm	02
16	210700-01	CARBON STEEL SPRING PIN 2X16mm	01
17	070280-01	Body Sticker (Left)	01
18	070281-01	Body Sticker (Right)	01
19	210100-01	DRIVING WEDGE (MACHINED)	01
20	211600-01	SPACER SHIM	01
21	220800-01	800kg MINI RATCHET STRAP	01

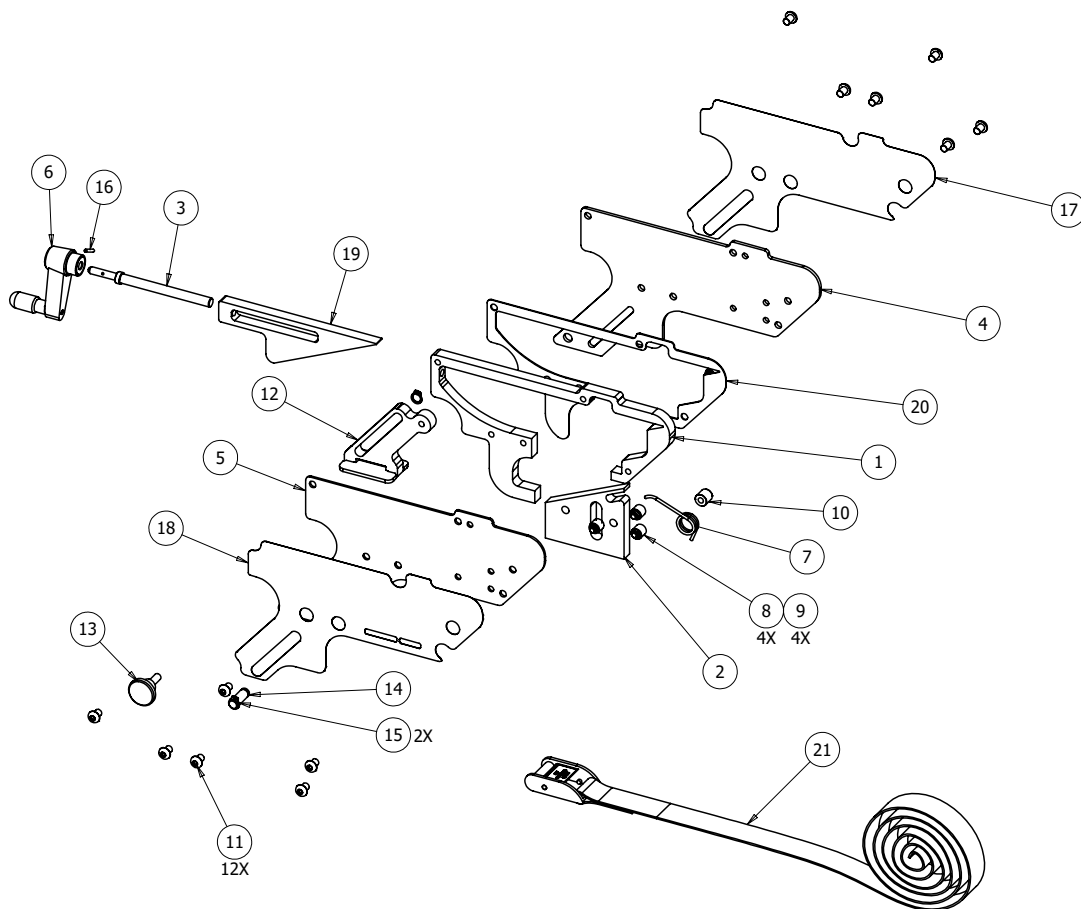



Notes

Notes

Notes



EQUALIZERTM
AN ENERPAC BRAND



EQUALIZER INTERNATIONAL LTD.

Head Office
Equalizer House
Claymore Drive
Aberdeen
Scotland
UK

AB23 8GD

t: +44 (0) 1224 701970

f: +44 (0) 1224 823791

www.equalizerinternational.com