

Model	Pump	Cylinder	Jack Assembly
IPA-20073	PAM-3042A	RR-20013	CF426.900
IPE-20060	PER-3042	RR-20013	CF426.900
IPE-20065	PER-5045	RR-20013	CF426.900
IPE-20068	PEM-8418	RR-20013	CF426.900
IPH-20080	P-464	RR-20013	CF426.900

TO PROTECT YOUR WARRANTY, USE ONLY ENERPAC HYDRAULIC OIL.

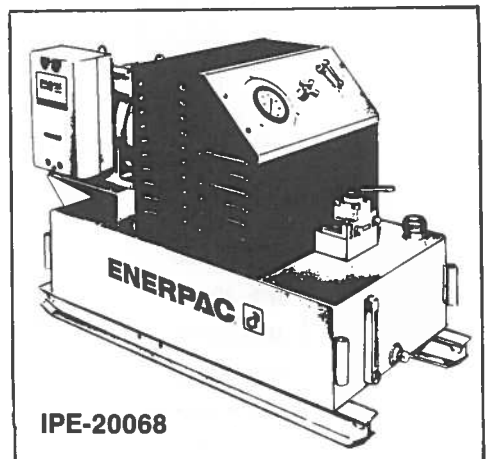
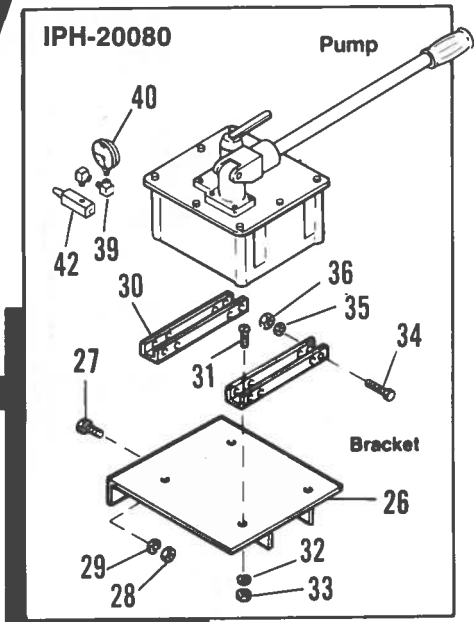
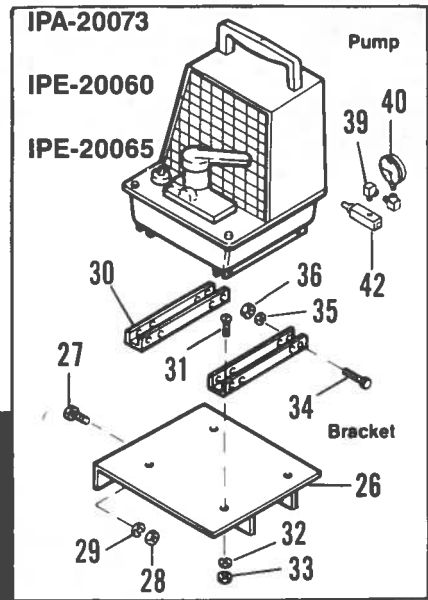
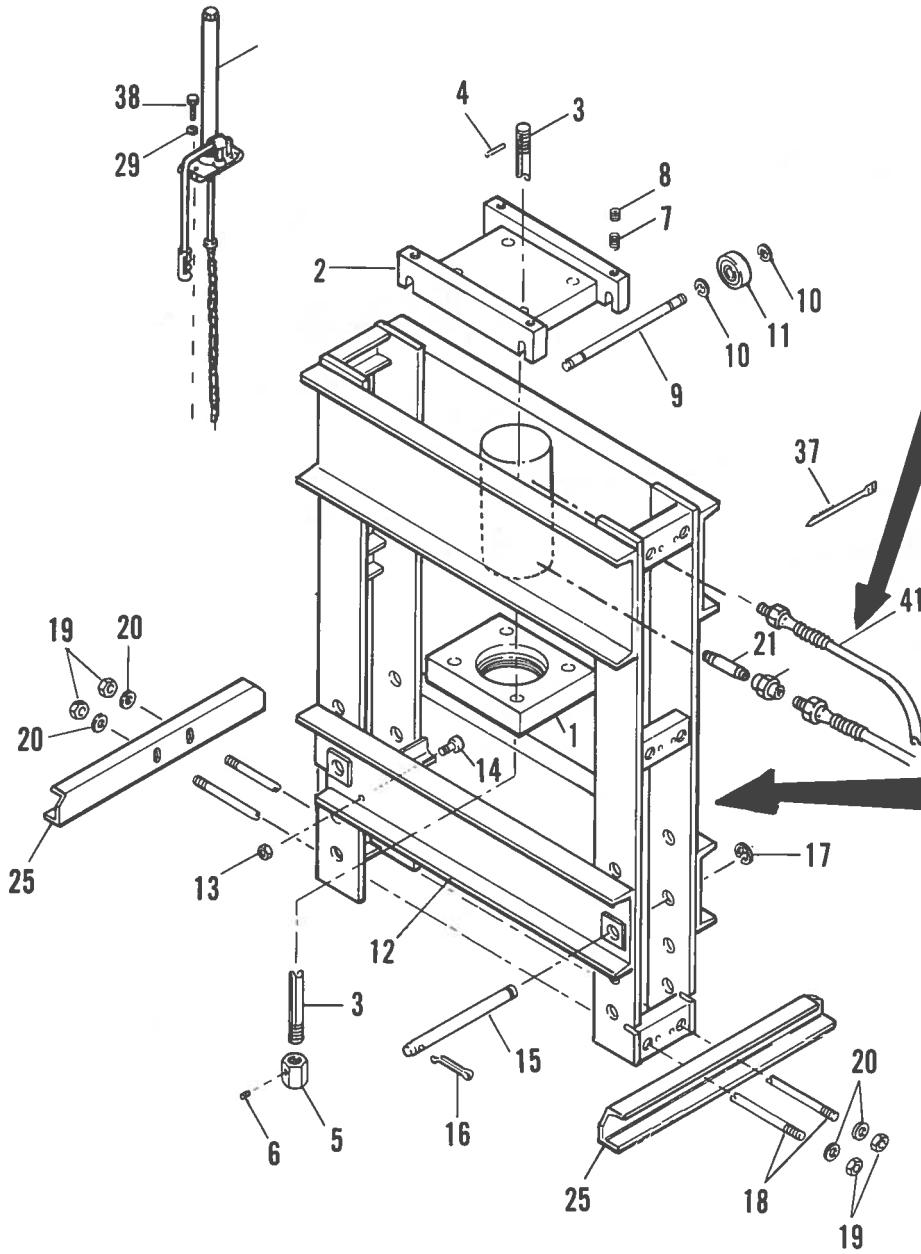

PARTS LIST (Figure 1)

ITEM NUMBER	PART NUMBER					DESCRIPTION	QTY
	IPA-20073	IPE-20060	IPE-20065	IPE-20068	IPH-20080		
1	CR17.111	CR17.111	CR17.111	CR17.111	CR17.111	Bracket, Cylinder	1
2	CR16.900	CR16.900	CR16.900	CR16.900	CR16.900	Support, Upper	1
3	CR1.149	CR1.149	CR1.149	CR1.149	CR1.149	Rod, Tie	4
4	B1062.057	B1062.057	B1062.057	B1062.057	B1062.057	Pin, Straight	4
5	CN742.550	CN742.550	CN742.550	CN742.550	CN742.550	Grip, Hex.	4
6	CJ999.028	CJ999.028	CJ999.028	CJ999.028	CJ999.028	Setscrew	4
7	CN999.110	CN999.110	CN999.110	CN999.110	CN999.110	Spring	4
8	A8024.027	A8024.027	A8024.027	A8024.027	A8024.027	Lockscrew	4
9	CN821.104	CN821.104	CN821.104	CN821.104	CN821.104	Axle	2
10	CN725.044	CN725.044	CN725.044	CN725.044	CN725.044	Ring, Retaining	8
11	CN723.107	CN723.107	CN723.107	CN723.107	CN723.107	Bearing	4
12	CF422.900	CF422.900	CF422.900	CF422.900	CF422.900	Bolster	1
13	B1018.120	B1018.120	B1018.120	B1018.120	B1018.120	Nut	8
14	CF490.107	CF490.107	CF490.107	CF490.107	CF490.107	Bearing	4
15	CU466.900	CU466.900	CU466.900	CU466.900	CU466.900	Pin, Bolster	2
16	CF525.061	CF525.061	CF525.061	CF525.061	CF525.061	Pin, Clinch	2
17	CA161.044	CA161.044	CA161.044	CA161.044	CA161.044	O-Ring	2
18	CN738.149	CN738.149	CN738.149	CN738.149	CN738.149	Rod, Third Leg	2
19	B1019.120	B1019.120	B1019.120	B1019.120	B1019.120	Nut	4
20	B1024.066	B1024.066	B1024.066	B1024.066	B1024.066	Washer	4
21	Cu799.096	CU799.096	CU799.096	CU799.096	CU799.096	Nipple	1
22	CJ649.096	CJ649.096	CJ649.096	CJ649.096	CJ649.096	Connector	1
23	CB804.045	CB804.045	CB804.045	CB804.045	CB804.045	Saddle	1
24	B1069.028	B1069.028	B1069.028	B1069.028	B1069.028	Capscrew	2
25	L887.634	L887.634	L887.634	L887.634	L887.634	Channel	2
26	CA836.111	CA836.111	CA836.111	-----	CA836.111	Bracket, Pump	1
27	CB528.046	CB528.046	CB528.046	-----	CB528.046	Capscrew, Bracket	6
28	B1003.120	B1003.120	B1003.120	-----	B1003.120	Nut, Bracket	6
29	B1001.066	B1001.066	B1001.066	-----	B1001.066	Washer, Bracket	6
30	CH132.111	CH132.111	CH132.111	-----	CH132.111	Bracket, Pump	2
31	B1039.046	B1039.046	B1039.046	-----	B1039.046	Capscrew	4
32	B1002.066	B1002.066	B1002.066	-----	B1002.066	Lockwasher	4
33	B1003.123	B1003.123	B1003.123	-----	B1003.123	Nut, Bracket	4
34	B1201.046	B1201.046	B1201.046	-----	B1201.046	Bolt	2
35	B1007.066	B1007.066	B1007.066	-----	B1007.066	Washer	2
36	B1013.120	B1013.120	B1013.120	-----	B1013.120	Nut, Hex.	2
37	CF965.017	CF965.017	CF965.017	CF965.017	CF965.017	Strap, Hose	1
38	CH204.028	CH204.028	CH204.028	CH204.028	CH204.028	Capscrew, Jack	4
39	CF641.291	CF641.291	CF641.291	CF641.291	CF641.291	Elbow, Street	2
40	GF-200S	GF-200S	GF-200S	GF-200S	GF-200S	Gauge, Pressure	1
41	HC-960U	HC-960U	HC-960U	HC-960U	HC-960U	Hose Assy.	2
42	HP-2344	HP-2344	HP-2344	HP-2344	HP-2344	Adaptor	1

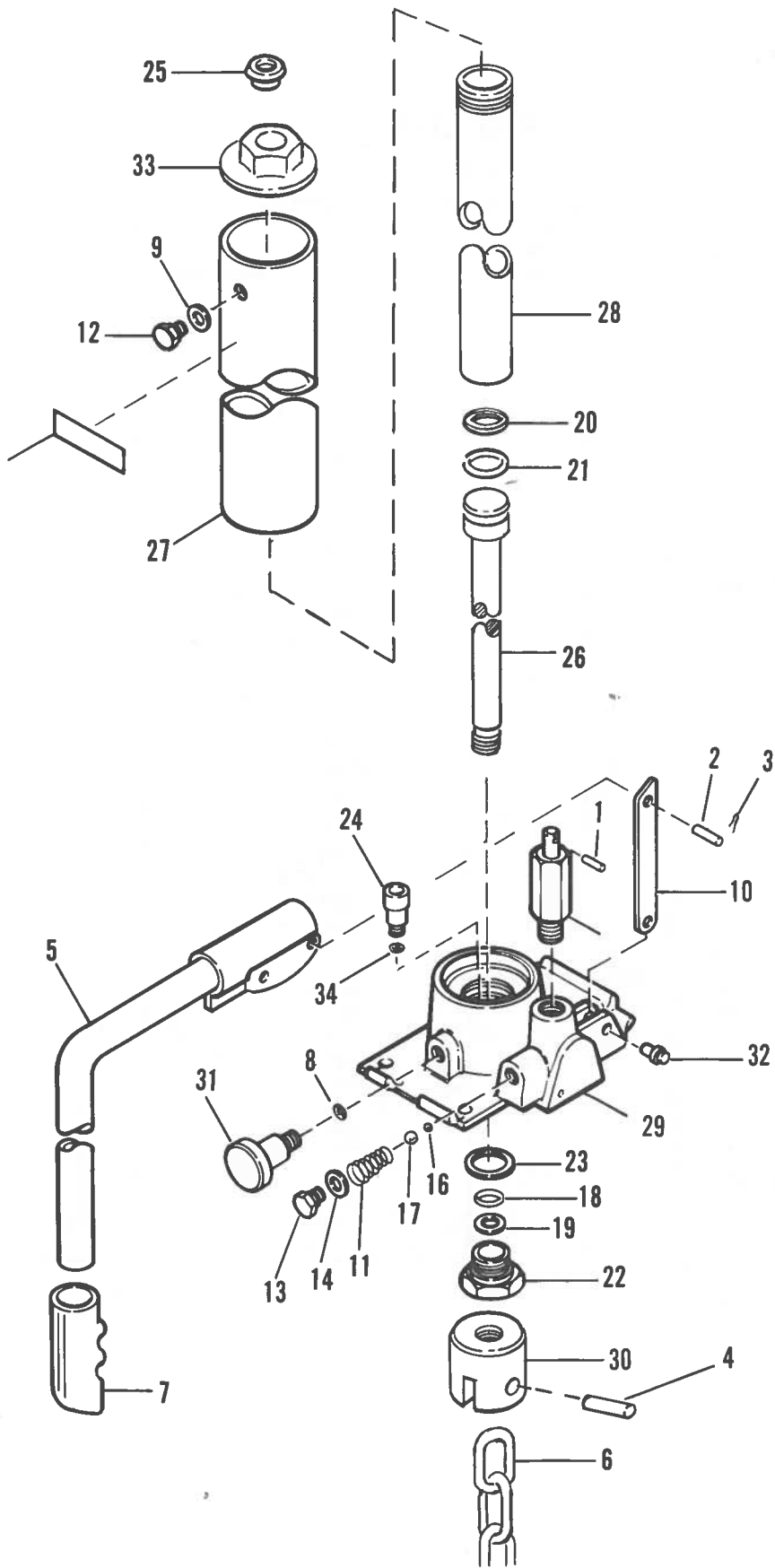

PARTS LIST

Figure 2

CF426.900 3 Ton Jack Assembly

Item No.	Part Number	No. Req'd.	Description
1	AJ100062	1	Pin, Beam
2	AJ100063	1	Pin, Clevis
3	B1001.058	2	Pin, Cotter
4	B1168.057	1	Pin, Spring
5	M276.900	1	Handle Assy.
6	CF439.066	1	Chain
7	E709.550	1	Grip
8	0106	1	Plug
9	AJ100020	1	Gasket
10	AJ100035	1	Link
11	AJ100040	1	Spring, Valve
12	AJ100060	1	Plug
13	AJ100061	1	Plug, Fill
14	B159.167	1	Gasket
15	B1003.503	1	O-Ring
16	B1006.016	1	Ball 7/32"
17	B1009.016	1	Ball
18	B1012.503	1	O-Ring
19	B1031.562	1	Ring, Backup
20	B1121.564	1	Ring, Backup
21	B1256.503	1	O-Ring
22	C170.055	1	Nut, Gland
23	C213.167	1	Gasket
24	C949.900	1	Valve, Relief
25	CF427.006	1	Plug
26	CJ758.900	1	Plunger
27	CF430.025	1	Reservoir
28	CF431.030	1	Cylinder
29	CF432.005	1	Base
30	CF433.132	1	Yoke
31	K2.010	1	Valve, Relief
32	K494.061	1	Pin
33	CJ100.099	1	Cap, Top
34	S3.037	1	Gasket
35	CF431.030	1	Cylinder
36	K584.900	1	Pump Assy.

REPAIR AND SERVICE INSTRUCTIONS: For repair service and parts contact your nearest ENERPAC Authorized Technical Service Center. The ENERPAC Technical Service Center will provide complete and prompt service on all ENERPAC products. For the location of an ENERPAC Service Center, call **Toll Free 1-800-433-2766. (In Wisconsin CALL 1-800-242-6636 — In Canada CALL 1-800-268-6975)**

NOTE: This phone number is not for product repair information.

For service related information contact ENERPAC Service Department 1-414-781-6600

PARTS AND SERVICE: For quality workmanship and genuine ENERPAC parts, select an Authorized ENERPAC Technical Service Center for your repair needs. Only repairs performed by an Authorized Service Center displaying the official ENERPAC sign are backed with full factory warranty. The Classified Section in Your Phone Book lists your nearest Service Center.

All ENERPAC tools are guaranteed from date of delivery to user against defects in workmanship and materials. Free repair or replacement will be made on all items not standing up to this guarantee. Following manufacturers trade customs, however, chains cannot be guaranteed. Warranty does not cover ordinary wear and tear, abuse or misuse, overloading, altered products or use of improper fluids. For prompt handling, send items requiring repairs prepaid, to your nearest ENERPAC authorized service center.

WARRANTY RETURN PROCEDURE: When question of warranty claim arises, the user should send his unit to the nearest ENERPAC Authorized Technical Service Center for inspection, transportation to be prepaid and evidence of purchase date furnished. If the claim comes under the terms of our warranty, the Authorized Technical Service Center will REPAIR OR REPLACE PARTS AFFECTED and return prepaid.

ENERPAC 