

**To Protect Your Warranty, Use Only ENERPAC Hydraulic Oil.**

Enerpac recommends that all kit components be installed to insure optimum performance of the repaired product.

**1.0 Remove Swing Clamp from Hydraulic System**

1. Shut down operation and release hydraulic pressure at the power source and holding valve (if used).
2. Disconnect the hydraulic line from the swing clamp. Wipe off excess oil.
3. Detach the swing clamp from its mounting by removing two bolts.

**2.0 Disassemble the Swing Clamp**

1. Remove one retaining ring from the fulcrum pin and pull pin out to free the clamping arm.
2. Remove clamping arm and spring from swivel fulcrum. Mark the position of the spring on the fulcrum for future reference.
3. Loosen set screw enough to remove cover.



**WARNING:** Cover is installed under slight spring pressure. Remove cover carefully to avoid injury.

4. Unscrew end plug and remove o-ring. Tap body lightly to remove plunger. Remove retaining ring, washer, plunger spring, o-ring, and back-up ring from the plunger. Discard o-ring and back-up ring.
5. Remove closure disc from the swivel fulcrum by tapping sharply on the fulcrum until the disc comes off. Remove swivel fulcrum through hole at bottom of swing clamp body.
6. Unscrew plunger housing from the swing clamp body. (For ASC-100: Remove snap ring from the plunger housing.) Remove plunger housing, internal spring, external spring, clamp plunger, and spring washer from the body.
7. Remove retaining ring to free check valve assembly, return spring, and o-ring. Do not discard retaining ring.
8. Remove felt ring (ASC-100 only), o-rings, and back-up rings and discard.



**3.0 Clean and Inspect the Parts**

1. Use OSHA approved degreasing solvent to clean the parts thoroughly. Blow them dry with clean moisture-free air and place them on a lint-free area
2. Inspect all parts for wear. Replace if necessary.
3. Replace the felt ring, o-rings, and back-up rings with new ones from the Repair Kit.

**4.0 Re-Assemble the Swing Clamp**

1. Re-assemble the unit. It may require slight hammering when installing the closure disc.
2. Use new parts from the Enerpac Repair Kit. Use all parts in the Repair Kit. DO NOT reinstall used seals.
3. Be sure all parts to be assembled are clean. Do not allow debris or contaminants to enter the unit.  
See notes on page 2.

**NOTES:**

1. Operating pressure is 1200 to 2500 psi.
2. ASC-30 only: Use thread sealant on plunger housing threads (Item 24).

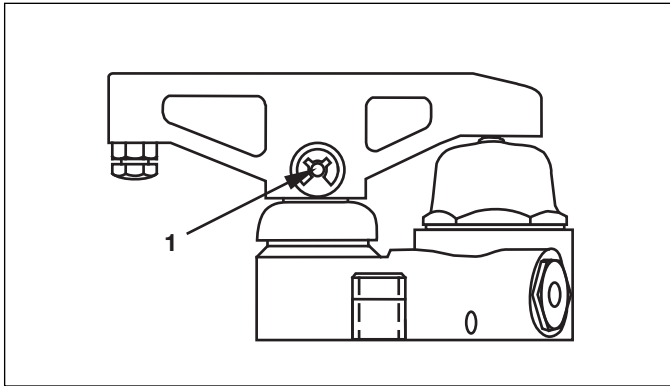

**ASC-30 - Side View Cutaway**

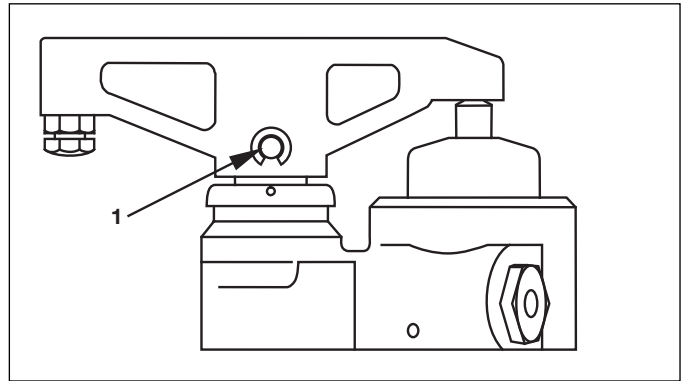

**ASC-100 - Side View Cutaway**

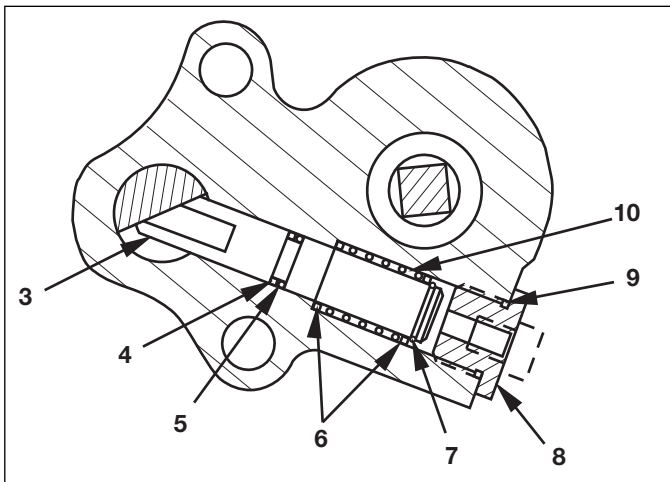

**ASC-30 - Top View Cutaway**

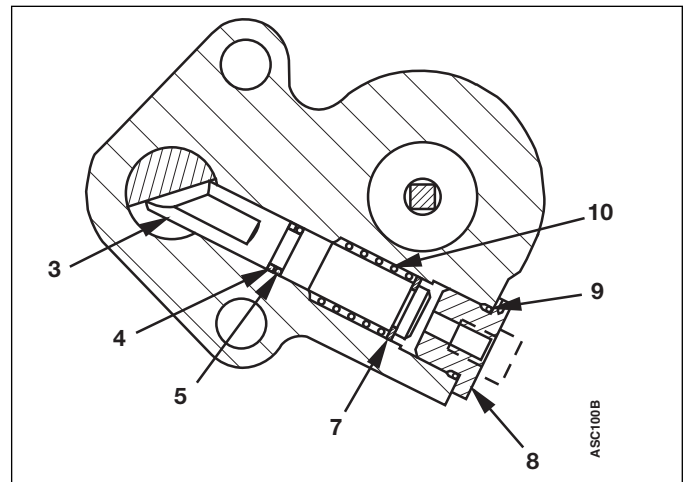

**ASC-100 - Top View Cutaway**

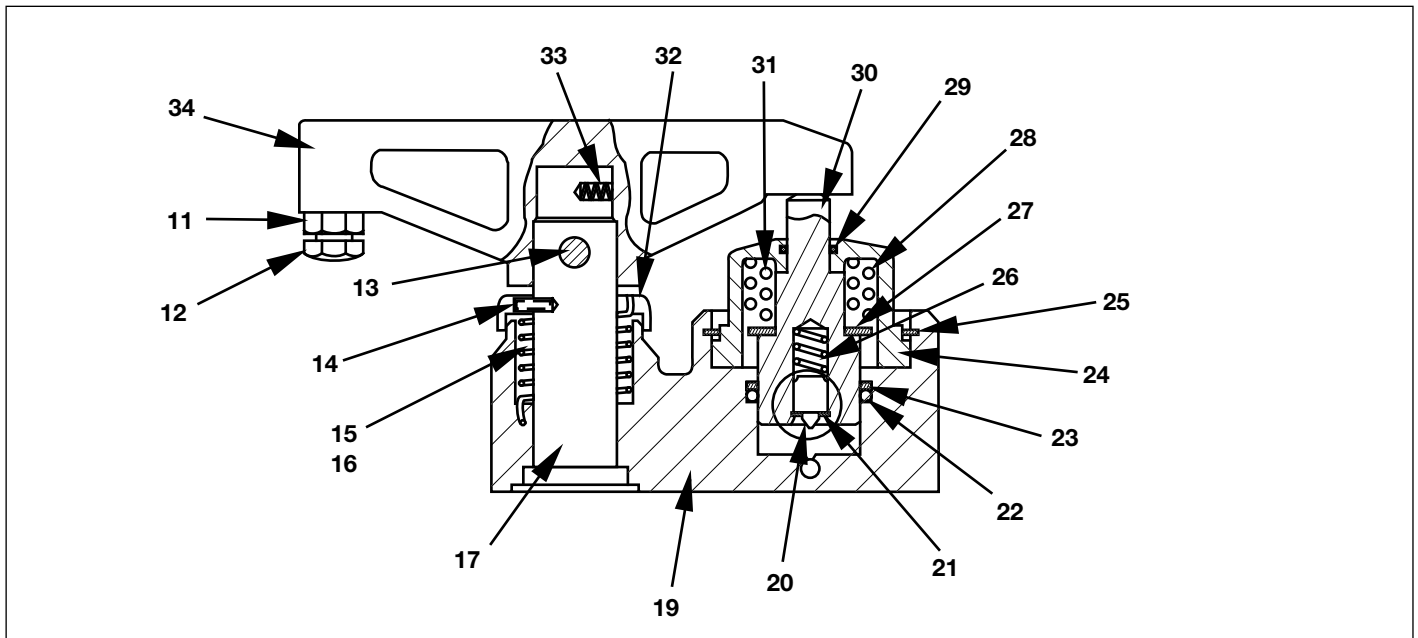

**ASC-30 - Swing Clamp Side View Cutaway**

| Repair Parts List                             |              |               |      |                      |
|---|--------------|---------------|------|----------------------|
| Item  | Model ASC-30 | Model ASC-100 | Qty. | Description          |
| 1   | 401809       | 401499        | 2    | Retaining Ring       |
| 3   | 401816       | 401807        | 1    | Plunger              |
| 4   | ★ B1110564   | ★ B1113564    | 1    | Back-Up Washer       |
| 5   | ★ B1008503   | ★ B1011503    | 1    | O-ring               |
| 6   | 401483       |               | 2    | Washer               |
| 7   | 401815       | DA1985044     | 1    | Retaining Ring       |
| 8   | 401465       | 403046        | 1    | End Plug             |
| 9   | ★ B1908503   | ★ B1912503    | 1    | O-ring               |
| 10  | 401226       | 404001        | 1    | Plunger Spring       |
| 11  | B1009123     | B1009123      | 1    | Jam Nut              |
| 12  | 4015121      | 4015122       | 1    | Bolt                 |
| 13  | 401810       | 401507        | 1    | Fulcrum Pin          |
| 14  | 401485       | 401513        | 1    | Set Screw            |
| 15  | 401472       | 401841        | 1    | R.H. Torsion Spring  |
| 16  | DD3114310    | 401278        | 1    | L.H. Torsion Spring  |
| 17  | PA2662010    | 401519        | 1    | Swivel Fulcrum       |
| 19  | PA2663005    | DC1520005     | 1    | Swing Clamp Body     |
| 20  | 430106       | 430106        | 1    | Check Valve Assembly |
| 21  | 401481       | 401481        | 1    | Retaining Ring       |
| 22  | ★ B1117903   | ★ B1028503    | 1    | O-ring               |
| 23  |              | ★ B1325564    | 1    | Back-Up Washer       |
| 24  | 401389       | 401511        | 1    | Plunger Housing      |
| 25  | 401503       |               | 1    | Retaining Ring       |
| 26  | 401230       | 401230        | 1    | Return Spring        |
| 27  | 401288       | 401680        | 1    | Spring Washer        |
| 28  | 401229       | 401266        | 1    | External Spring      |
| 29  | ★ B1114203   |               | 1    | O-ring               |
| 30  | 401811       | 401804        | 1    | Clamp Plunger        |
| 31  | 401227       | 401265        | 1    | Internal Spring      |
| 32  | 401476       | 401506        | 1    | Cover                |
| 33  | 401238       | 401238        | 1    | AMR Spring           |
| 34  | 401929       | 401931        | 1    | Clamping Arm         |
| ★   | ASC30K       | ASC100K       |      | Repair Kit           |
| ★ Indicates items included in the Repair Kit. |              |               |      |                      |

## Enerpac Worldwide Locations

◆ e-mail: [info@enerpac.com](mailto:info@enerpac.com)

◆ internet: [www.enerpac.com](http://www.enerpac.com)

### Australia and New Zealand

Actuant Australia Ltd.  
Block V Unit 3  
Regents Park Estate  
391 Park Road  
Regents Park NSW 2143  
(P.O. Box 261) Australia  
T +61 297 438 988  
F +61 297 438 648  
[sales-au@enerpac.com](mailto:sales-au@enerpac.com)

### Brazil

Power Packer do Brasil Ltda.  
Rua dos Inocentes, 587  
04764-050 - Sao Paulo (SP)  
T +55 11 5687 2211  
F +55 11 5686 5583  
Toll Free: 0800 891 5770  
[vendasbrasil@enerpac.com](mailto:vendasbrasil@enerpac.com)

### Canada

Actuant Canada Corporation  
6615 Ordan Drive, Unit 14-15  
Mississauga, Ontario L5T 1X2  
T +1 905 564 5749  
F +1 905 564 0305  
Toll Free:  
T +1 800 268 4987  
F +1 800 461 2456  
[customer.service@actuant.com](mailto:customer.service@actuant.com)

### China (Taicang)

Actuant (China) Industries Co. Ltd.  
No.6 Nanjing Road,  
Taicang Economic Dep Zone  
Jiangsu, China  
T +86 0512 5328 7500  
F +86 0512 5335 9690  
[sales-cn@enerpac.com](mailto:sales-cn@enerpac.com)

### China (Beijing)

Actuant (China) Industries Co. Ltd.  
709B Diyang Building  
Xin No. 2, Dong San Huan North Rd.  
Beijing City, 100028 China  
T +86 10 845 36166  
F +86 10 845 36220  
[sales-cn@enerpac.com](mailto:sales-cn@enerpac.com)

### France, Switzerland, North Africa and French speaking African countries

ENERPAC  
Une division d'ACTUANT France  
S.A.S.  
ZA de Courtaboeuf  
32, avenue de la Baltique  
91140 VILLEBON /YVETTE  
France  
T +33 1 60 13 68 68  
F +33 1 69 20 37 50  
[sales-fr@enerpac.com](mailto:sales-fr@enerpac.com)

### Germany and Austria

ENERPAC GmbH  
P.O. Box 300113  
D-40401 Düsseldorf  
Willstätterstrasse 13  
D-40549 Düsseldorf, Germany  
T +49 211 471 490  
F +49 211 471 49 28  
[sales-de@enerpac.com](mailto:sales-de@enerpac.com)

### India

ENERPAC Hydraulics Pvt. Ltd.  
No. 1A, Peenya Industrial Area  
IInd Phase, Bangalore, 560 058, India  
T +91 80 40 792 777  
F +91 80 40 792 792  
[sales-in@enerpac.com](mailto:sales-in@enerpac.com)

### Italy

ENERPAC S.p.A.  
Via Canova 4  
20094 Corsico (Milano)  
T +39 02 4861 111  
F +39 02 4860 1288  
[sales-it@enerpac.com](mailto:sales-it@enerpac.com)

### Japan

Applied Power Japan LTD KK  
Besshocho 85-7  
Kita-ku, Saitama-shi 331-0821, Japan  
T +81 48 662 4911  
F +81 48 662 4955  
[sales-jp@enerpac.com](mailto:sales-jp@enerpac.com)

### Middle East, Egypt and Libya

ENERPAC Middle East FZE  
Office 423, LOB 15  
P.O. Box 18004, Jebel Ali, Dubai  
United Arab Emirates  
T +971 (0)4 8872686  
F +971 (0)4 8872687  
[sales-ua@enerpac.com](mailto:sales-ua@enerpac.com)

### Russia

Rep. office Enerpac  
Russian Federation  
Admirala Makarova Street 8  
125212 Moscow, Russia  
T +7 495 98090 91  
F +7 495 98090 92  
[sales-ru@enerpac.com](mailto:sales-ru@enerpac.com)

### Singapore

Actuant Asia Pte Ltd.  
83 Joo Koon Circle  
Singapore 629109  
T +65 68 63 0611  
F +65 64 84 5669  
Toll Free: +1800 363 7722  
[sales-sg@enerpac.com](mailto:sales-sg@enerpac.com)

### South Korea

Actuant Korea Ltd.  
3Ba 717, Shihwa Industrial Complex  
Jungwang-Dong, Shihung-Shi,  
Kyunggi-Do  
Republic of Korea 429-450  
T +82 31 434 4506  
F +82 31 434 4507  
[sales-kr@enerpac.com](mailto:sales-kr@enerpac.com)

### Spain and Portugal

ENERPAC SPAIN, S.L.  
Avda. Los Frailes, 40 – Nave C & D  
Pol. Ind. Los Frailes  
28814 Daganzo de Arriba  
(Madrid) Spain  
T +34 91 884 86 06  
F +34 91 884 86 11  
[sales-es@enerpac.com](mailto:sales-es@enerpac.com)

### Sweden, Denmark, Norway, Finland and Iceland

Enerpac Scandinavia AB  
Fabriksgatan 7  
412 50 Gothenburg  
Sweden  
T +46 (0) 31 799 0281  
F +46 (0) 31 799 0010  
[scandinavianinquiries@enerpac.com](mailto:scandinavianinquiries@enerpac.com)

### The Netherlands, Belgium, Luxembourg, Central and Eastern Europe, Baltic States, Greece, Turkey and CIS countries

ENERPAC B.V.  
Galvanistraat 115  
6716 AE Ede  
P.O. Box 8097  
6710 AB Ede  
The Netherlands  
T +31 318 535 800  
F +31 318 535 848  
[sales-nl@enerpac.com](mailto:sales-nl@enerpac.com)

Enerpac Integrated Solutions B.V.  
Opaalstraat 44  
7554 TS Hengelo  
P.O. Box 421  
7550 AK Hengelo  
The Netherlands  
T +31 74 242 20 45  
F +31 74 243 03 38  
[integratedsolutions@enerpac.com](mailto:integratedsolutions@enerpac.com)

### South Africa and other English speaking African countries

ENERPAC B.V.  
Galvanistraat 115  
6716 AE Ede  
P.O. Box 8097  
6710 AB Ede  
The Netherlands  
T +31 318 535 911  
F +31 318 525 613  
[sales-za@enerpac.com](mailto:sales-za@enerpac.com)

### United Kingdom and Ireland

ENERPAC Ltd.,  
Bentley Road South  
Darlaston, West Midlands  
WS10 8LQ  
England  
T +44 (0)121 50 50 787  
F +44 (0)121 50 50 799  
[sales-uk@enerpac.com](mailto:sales-uk@enerpac.com)

### USA, Latin America and Caribbean

ENERPAC  
P.O. Box 3241  
6100 N. Baker Road  
Milwaukee  
WI 53209 USA  
T +1 262 781 6600  
F +1 262 783 9562  
User inquiries:  
+1 800 433 2766  
Distributor inquiries/orders:  
+1 800 558 0530  
[sales-us@enerpac.com](mailto:sales-us@enerpac.com)

All Enerpac products are guaranteed against defects in workmanship and materials for as long as you own them.

For the location of your nearest authorized Enerpac Service Center, visit us at [www.enerpac.com](http://www.enerpac.com)

01/25/11