

**L1840 Rev. B 11/2017**

**IMPORTANT RECEIVING INSTRUCTIONS**

Visually inspect all components for shipping damage. If any shipping damage is found, notify carrier at once. Shipping damage is NOT covered by warranty. The carrier is responsible for all repair or replacement cost resulting from damage during shipment.

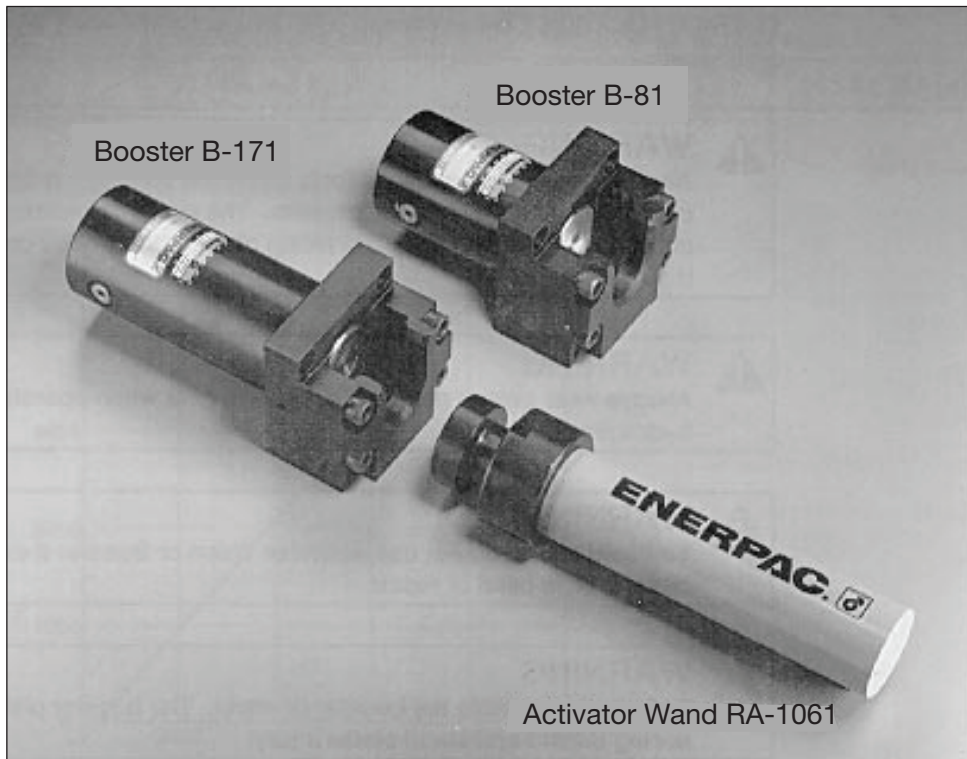

**CONTENTS**

**Page**

DESCRIPTION .....	2
SAFETY INFORMATION .....	2
SPECIFICATIONS .....	3
INSTALLATION .....	4
OPERATION .....	6
TROUBLESHOOTING .....	7
MAINTENANCE .....	8

## DESCRIPTION

The Wand and Booster system is primarily for use in flexible machining centers in which the power source does not remain connected to the fixture. This system is ideal for simple applications with relatively low fluid capacities. The energy transfer in the system is mechanical, making it highly tolerant of contaminants. In addition, the fixture and the hydraulic power supply systems are not coupled by hydraulic quick disconnects, isolating the hydraulic fluid from external contamination.

## SAFETY INFORMATION

To avoid personal injury or property damage during the system operation, read and follow all CAUTIONS, WARNINGS, and INSTRUCTIONS included with, or attached to, each product. ENERPAC CANNOT BE RESPONSIBLE FOR DAMAGE OR INJURY RESULTING FROM UNSAFE USE OF PRODUCT, LACK OF MAINTENANCE, OR INCORRECT PRODUCT AND/OR SYSTEM APPLICATION. Contact Enerpac when in doubt about safety precautions or applications.



### WARNING

Always check product limitations regarding pressure ratings, load capacities, and set-up requirements. The system operating pressure must not exceed the pressure rating of the lowest-rated component in the system.



### WARNING

Always wear proper personal protective gear when operating hydraulic equipment.



### WARNING

To avoid injury, do not use Activator Wand or Booster if damaged, altered, or in need of repair.



### WARNING

Do not disassemble the booster or wand. The booster piston is spring loaded and could cause injury.



### CAUTION

Keep fixture, booster, and wand clear of chips. The accumulation of chips will obstruct flow through the Booster flange.

## SPECIFICATIONS

Model	Wand RA-1061	Booster B-81	Booster B-171
Temperature Range	41° - 140°F [5° - 60°C]	41° - 140°F [5° - 60°C]	
Viscosity Range	150 - 165 S.U.S. [15 - 250 cSt]	150 - 165 S.U.S. [15 - 250 cSt]	
Oil Capacity (Cylinder)	9.91 cu. in. [162,4 cu.cm.]	8.12 cu. in. [133,0 cu.cm.]	17.11 cu. in. [280,4 cu. cm.]
Pressure	Max. 10,000 psi [690 BAR] Min. 300 psi [21 BAR]	Max. 5,000 psi [345 bar]	
Stroke	4.44 in. [112,8 mm.]	2.04 in. [51,8 mm.]	4.30 in. [109,2 mm]
Effective Area	2.23 sq. in. [14,4 sq.cm.]	3.98 sq. in. [25,7 sq. cm.]	
Weight	10.5 lbs. [4,8 Kg.]	12.5 lbs. [5,7 kg.]	14.5 lbs. [6,6 kg]

**Activator Wand Input Pressure vs. Booster Output Pressure**

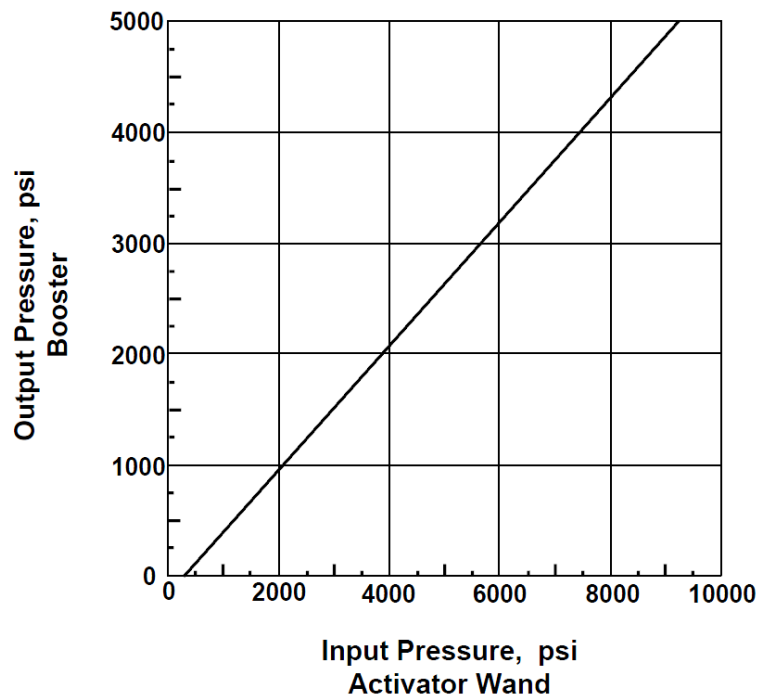
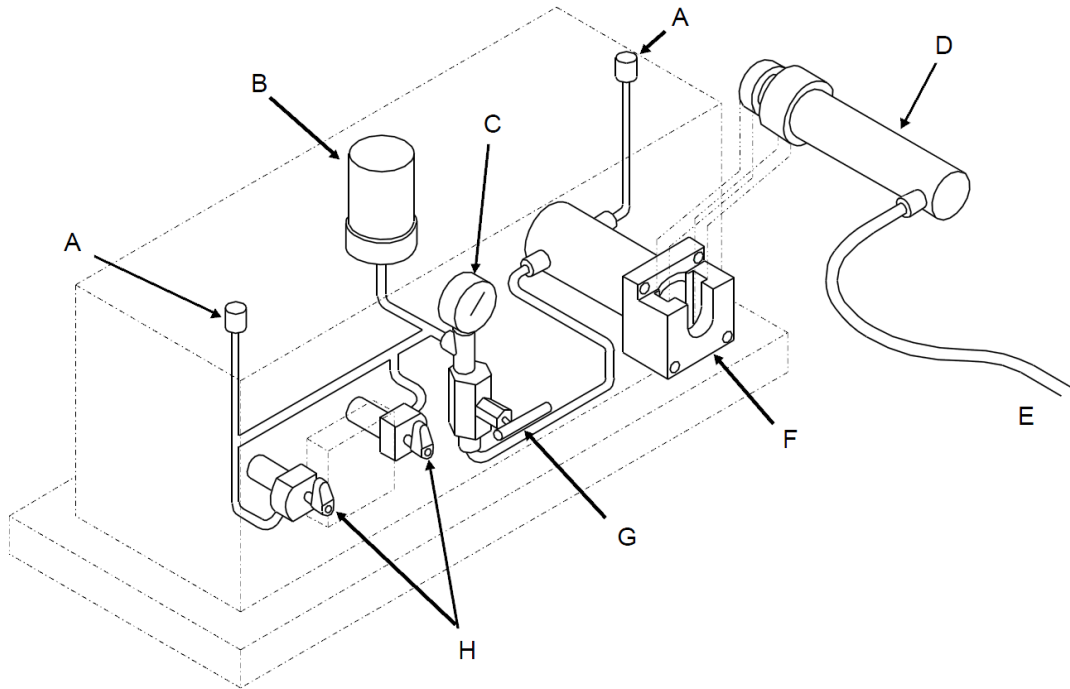

**Figure 1**

**NOTE:** Booster output flow rate will be approximately twice the flow rate of the power source used to pressurize the activator wand. Do not exceed the maximum flow rate of the lowest rated component in the system.

**INSTALLATION**

Figure 2 below shows a typical set-up for a single-acting swing cylinder system. Figure 3 is a hydraulic schematic of the system.



**Figure 2**

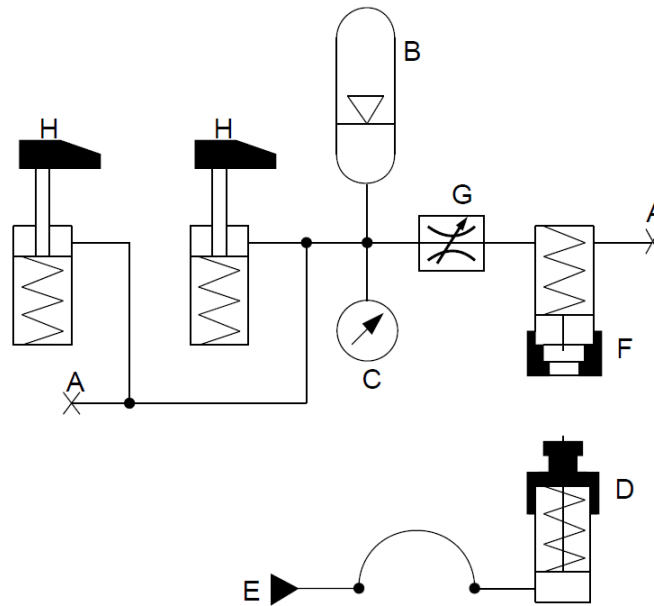

**Figure 3**

**Figure 2 and 3**

Item	Description	Item	Description
A	Bleeder Valve	E	To Power Source
B	Hydraulic Accumulator	F	Booster
C	Pressure Gauge	G	Shut-off Valve
D	Activator Wand	H	Swing Cylinders

## INSTALLATION (continued)

### System Set-up

Use two bleeder valves, one at each end of the circuit. Maximize tubing size. Tubing with a diameter of .375 inches [0,95 cm] is preferred. If necessary, more than one connection to the booster may be used. Booster connections are #4 SAE and are located on both sides and at the rear of the booster. Connect the power source to the Activator Wand 3/8 NPTF port, located on the side of the wand. Use 1 1/2 wraps of teflon tape on NPTF fittings, leaving the first complete thread free of tape to ensure that pieces of tape do not break off and enter the system, causing damage.



### CAUTION

Size the hydraulic circuit to 90% or less of the booster capacity to ensure proper operation.

**NOTE:** Customers interested in double-acting or other applications should contact Enerpac Technical Services.

### Mounting

Mount the booster on a readily accessible face of the fixture, with the flange exposed externally and the pressure cylinder recessed. Select a location which will minimize the build-up of metal chips. Use two 3/8 -16 UNC x 1.25 in. and two 3/8 - 16 UNC x 3.00 in. steel socket head capscrews. See Figure 4 for mounting dimensions.

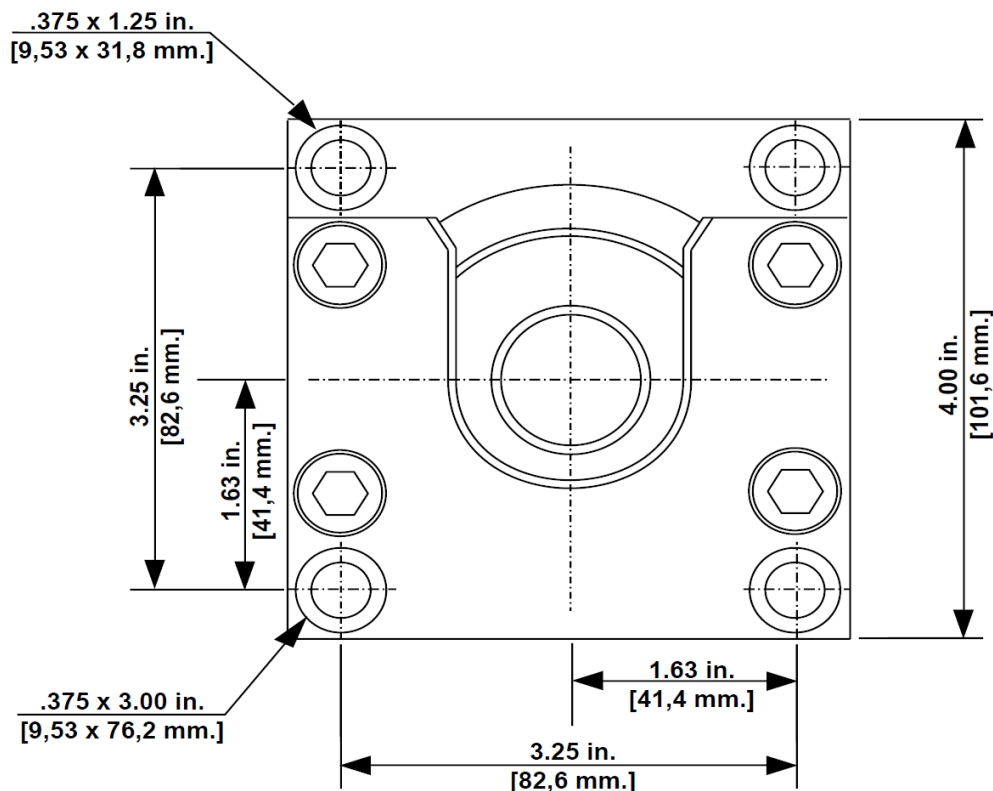

Figure 4

## Adding Hydraulic Fluid

1. Connect a pump to one bleeder valve connection.
2. Open the other bleeder valve.
3. Pump hydraulic fluid into the system until it drains out of the bleeder valve.  
The system pressure gauge should remain at 0 psi while fluid is being added.
4. Disconnect the pump from the circuit and close the bleeder valves.

## Bleeding the Circuit

1. Make sure bleeder valves are closed.
2. Energize the fixture several times, using the activator wand at low pressure (1,000 psi).
3. With the fixture energized, slightly open the bleeder valves to release any trapped air.
4. Close bleeder valves.
5. Add hydraulic fluid if necessary.
6. Remove air from the wand by fully extending the plunger. Then position the wand lower than its power source with the plunger facing down and allow it to retract.
7. Repeat until the motion of the plunger is smooth.

## OPERATION

### Load Cycle

1. Load the workpieces into the fixture.
2. Make sure that the manual shut-off valve is open.
3. Put the activator wand into the booster.
4. Pressurize the activator wand.



#### **CAUTION**

**Make certain that the wand is fully seated in the booster/receiver base before pressurization or the activator wand or booster may be damaged.**

5. Visually check the clamped workpiece and the system pressure.



#### **WARNING**

**Keep hands away from booster during pressurization.**

6. Close the manual shut-off valve.
7. Depressurize the activator wand.

### Unload Cycle

1. Open the manual shut-off valve.
2. Unload the workpiece.

## TROUBLESHOOTING

The following information is intended as an aid in determining if a problem exists. Do not disassemble the booster or wand. For repair service, contact the Authorized Enerpac Service Center in your area.

<b>Problem</b>	<b>Possible Cause</b>	<b>Solution</b>
1) Fixture hydraulic circuit fails to attain desired pressure.	<p>A. Low activator wand pressure.</p> <p>B. Air trapped in the fixture circuit.</p> <p>C. Low hydraulic fluid level in fixture circuit.</p> <p>D. Booster hydraulic capacity is insufficient.</p> <p>E. Manual shut-off valve is closed.</p> <p>F. Fixture circuit has a leak.</p>	<p>Increase activator wand pressure.</p> <p>Bleed air from the circuit, following the instructions on page 6.</p> <p>Add oil to the circuit, following the instructions on page 6.</p> <p>Re-evaluate the system.</p> <p>Open manual shut-off valve.</p> <p>Check that all connections are tight.</p>
2) Fixture clamps do not achieve full stroke.	<p>A. Air trapped in fixture circuit.</p> <p>B. Low hydraulic fluid level in fixture circuit.</p> <p>C. Booster hydraulic capacity is insufficient.</p>	<p>Bleed air from the circuit, following the instructions on page 6.</p> <p>Add oil to the circuit, following the instructions on page 6.</p> <p>Re-evaluate the system.</p>
3) Fixture clamps unclamp too slowly.	<p>A. Hydraulic tubing size is too small.</p> <p>B. Manual shut-off valve is too restrictive.</p> <p>C. Air trapped in the fixture circuit.</p> <p>D. Failed booster return spring.</p>	<p>Use larger-sized tubing.</p> <p>Use a less restrictive manual shut-off valve.</p> <p>Bleed air from the circuit, following the instructions on page 6.</p> <p>Have booster serviced by a qualified hydraulic technician.</p>
4) Fixture clamps do not unclamp fully.	<p>A. Air trapped in the fixture circuit.</p> <p>B. Too much fluid in the hydraulic circuit.</p> <p>C. Failed booster return spring.</p> <p>D. Manual shut-off valve is closed.</p>	<p>Bleed air from the circuit, following the instructions on page 6.</p> <p>Remove excess oil from the system.</p> <p>Have booster serviced by a qualified hydraulic technician.</p> <p>Open manual shut-off valve.</p>
5) Activator wand retracts slowly.	<p>A. Flow restriction in activator wand circuit.</p> <p>B. Failed activator wand spring.</p>	<p>Check that all connections are tight.</p> <p>Have activator wand serviced by a qualified hydraulic technician.</p>

## MAINTENANCE



### **CAUTION**

**Keep fixture, wand, and booster free of chips. Use wash station to aid in clearing chips.**

To keep the system functioning properly, periodically:

1. Re-tighten mounting bolts.
2. Bleed air from the system and refill with Enerpac hydraulic fluid.



**POWERFUL SOLUTIONS. GLOBAL FORCE.**  
[www.enerpac.com](http://www.enerpac.com)