

Pneumatic Torque Wrench PTW Series

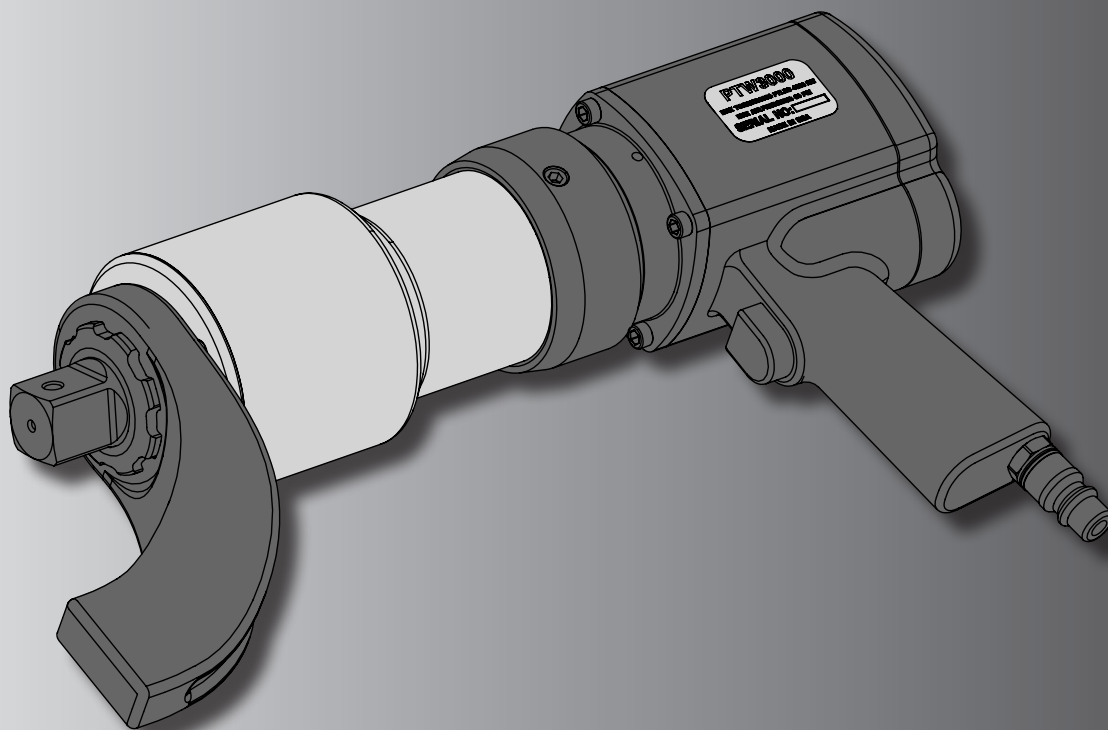

PTW1000
PTW2000
PTW3000
PTW6000

PTW Series Pneumatic Torque Wrench

PTW1000
PTW2000
PTW3000
PTW6000

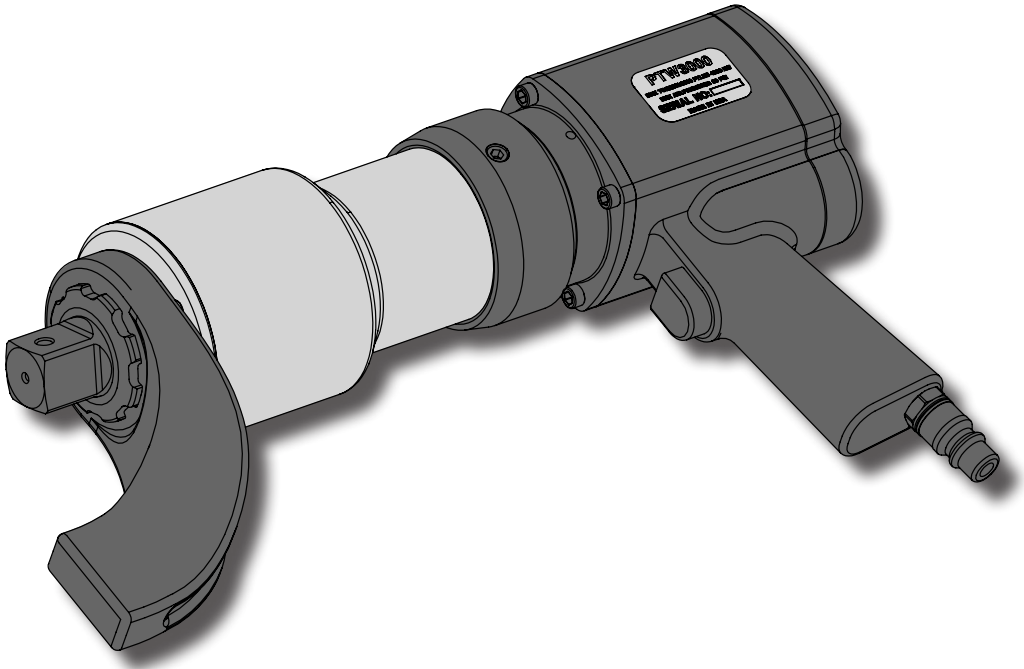

Index

1	Introduction	2
2	Safety	3
3	Assembly and Adjustment	5
4	Operation	6
5	Maintenance	9
6	Troubleshooting	9
7	Technical Specifications.....	10

PTW Series Pneumatic Torque Wrench

1 INTRODUCTION

Overview

The Enerpac PTW Series torque wrench is designed for controlled tightening and loosening of fasteners in industrial bolting applications. Optional reaction arms are available for different applications.

The PTW Series is available as a package with the following:

- 1 PTW Series Pneumatic Torque Wrench
- 1 Standard Reaction Arm
- 1 Storage Case
- 1 Air Hose (10 ft)
- 1 Air Filter Regulator Lubricator Unit (FRL)

Delivery Instructions

Upon delivery, all components must be inspected for damage incurred during shipping. If damage is found, the carrier should be notified at once. Shipping damage is not covered by the Enerpac warranty.

Warranty

- Enerpac guarantees the product only for the purpose for which it is intended.
- All Enerpac products are guaranteed against defects in workmanship and materials for as long as you own them. Any misuse or alteration invalidates the warranty.
- Observe all instructions as communicated in this manual.
- Use only genuine Enerpac replacement parts.

Conformance to National and International Standards



Enerpac declares that the product(s) have been tested and conforms to applicable standards and the product(s) are compatible to all EU and UK Requirements.

Copies of the EU Declaration as well as the UK Self-Declaration are enclosed with each shipment.

PTW Series Pneumatic Torque Wrench

2 SAFETY

Read all instructions carefully. Follow all recommended safety precautions to avoid personal injury as well as damage to the wrench and/or damage to other property. Enerpac cannot be responsible for any damage or injury from unsafe use, lack of maintenance or incorrect operation. Do not remove warning labels, tags or decals. In the event any questions or concerns arise, contact Enerpac or a local Enerpac distributor for clarification.

This manual follows a system of safety alert symbols, signal words and safety messages to warn the user of specific hazards. Failure to comply with these warnings could result in death or serious personal injury, as well as damage to the equipment or other property.

Safety Definitions



The **Safety Alert Symbol** appears throughout this manual. It is used to alert you to potential physical injury hazards. Pay close attention to Safety Alert Symbols and obey all safety messages that follow this symbol to avoid the possibility of death or serious personal injury.

Safety Alert Symbols are used in conjunction with certain Signal Words that call attention to safety messages or property damage messages and designate a degree or level of hazard seriousness. The Signal Words used in this manual are DANGER, WARNING, CAUTION and NOTICE.



DANGER

Indicates a hazardous situation, if not avoided, *will* result in death or serious personal injury.



WARNING

Indicates a hazardous situation, if not avoided, *could* result in death or serious personal injury.



CAUTION

Indicates a hazardous situation, if not avoided, *could* result in minor or moderate personal injury.

NOTICE

Indicates information considered important but not hazard-related (e.g., messages relating to property damage). Please note that the Safety Alert Symbol will **not** be used with this signal word.

NOTE: Indicates a procedure, practice or condition that should be followed in order for the tool to function in the manner intended.

General Safety

Be aware that the operator is fully responsible for the correct operation of this tool. Enerpac is not responsible for damage or injury caused by misuse of this tool. Under some circumstances, additional safety precautions beyond those described in this manual may be required. Read this manual carefully and observe all safety precautions.

- Be sure you have read and understood the instruction manual prior to using the tool. Contact Enerpac if you have questions.
- Make sure you have completed safety training, specific to the work surroundings. The operator should be thoroughly familiar with the controls and the proper use of the tool.
- The operator must be of at least the minimum age required by applicable local regulations, laws and the facility's standard operating procedures.
- Make sure your workplace is safe.

Follow instructions in your workplace's standard operating procedures and be sure to observe all communicated safety precautions.

PTW Series Pneumatic Torque Wrench

PTW Series Safety

The following warnings are specific to the PTW Series Pneumatic Torque Wrench.



DANGER

- Do not place any part of the body between the reaction arm and the reaction point.



WARNING

Failure to observe and comply with the following precautions could result in death or serious personal injury. Property damage could also occur.

- Be aware that a nut or bolt that breaks off during operation of the tool may become a high-velocity projectile.
- Never exceed the maximum air pressure shown on the supplied chart.
- Always wear protective headwear, ear protectors, footwear and gloves (at a minimum, rigger-type gloves) suitable for safe operation of the tool. The protective clothing must not interfere with safe operation of the tool or restrict the ability to communicate with coworkers.
- Do not place any objects between the reaction arm and the reaction point. Keep the hoses away from the reaction points.
- Tightening and loosening nuts and bolts involves little visible movement. The pressure and loads, however, are extreme. Keep your hands away from the fastener being loosened or tightened.
- Keep loose clothing, hair and other items from being caught in any rotating part of the tool.



CAUTION

Failure to observe and comply with the following precautions could result in minor or moderate personal injury. Property damage could also occur.

- Make sure the air supply is off prior to attaching or removing couplings or hoses. Be certain that all hose couplings are fully connected before applying air pressure.
- Always use sockets which are designed for use with powered wrenches.
- Always position the tool for maximum stability. Make sure reaction points are adequate for the forces at work during operation of the tool.
- Make sure the reaction point is of a suitable shape. For example, use an adjacent nut or bolt as a reaction point.
- The maximum torque output rating of the tool must always exceed the torque required to loosen or tighten the nut or bolt.
- Do not drop heavy objects on the hose. A sharp impact may cause internal damage to the hose. Applying pressure to a damaged hose may cause it to burst.

NOTICE

Failure to observe and comply with the following precautions could result in property damage and/or void the product warranty.

- Never use the air hoses to carry or move the tool or the Filter/Regulator/Lubricator (FRL) assembly.
- If the tool is dropped from a significant height, have the tool inspected before you operate it again.
- In severe conditions, the tool must be cleaned and inspected more frequently.
- Be sure to minimize torsional and bending stresses in the tool and any accessories.
- Avoid striking the tool at any time, even when it is not under load. Striking the tool could cause permanent damage to wrench components and may affect the wrench calibration.
- Always use Enerpac spare parts.
- Ensure that the tool and related equipment are in good working condition prior to use.

PTW Series Pneumatic Torque Wrench

3 ASSEMBLY AND ADJUSTMENT

The air source must be capable of at least 50 CFM (85 CMH) at 100 psi (6.9 bar). A minimum hose size of 1/2 inch (13 mm) must be used. The tool must be calibrated with the Filter/Regulator/Lubricator (FRL) that is being used. The PTW equipment (including tool and FRL) is to be used with an air supply that is regulated and/or limited to 120 psi (8.3 bar) maximum.

1. Check the air lubricator oil level and fill if needed. Only use SAE 10 or lighter clean, nondetergent oil. Remove the cap and add oil if needed.
2. Turn the drip rate adjustment knob to adjust the drip rate. The drip rate can be viewed through the clear adjustment knob. The drip rate should be checked while the tool is operating. Set the drip rate to between 4 and 6 drops per minute.

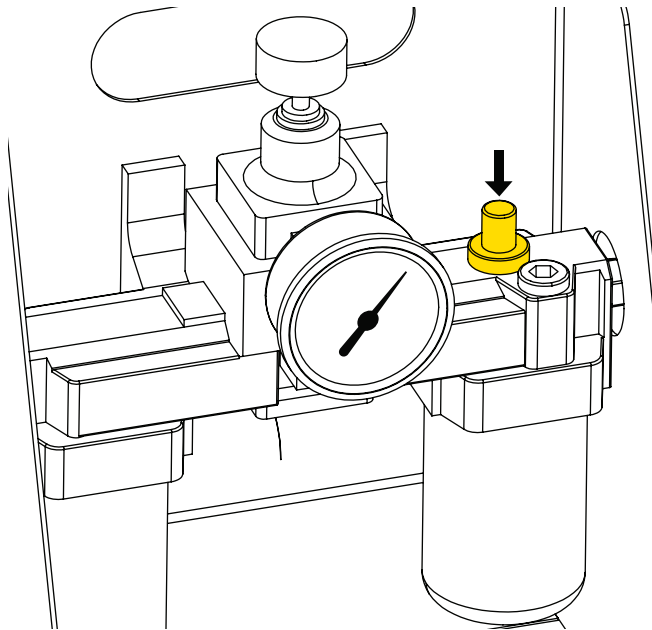

Fig. 1



WARNING: To prevent hazards created by hose whip, securely connect all connections before turning on the air supply.

NOTICE: Make sure hoses are free of debris and the ends are clean before connecting.

3. Install a quick coupler or air hose (not supplied) into the 1/2 inch NPT inlet port.

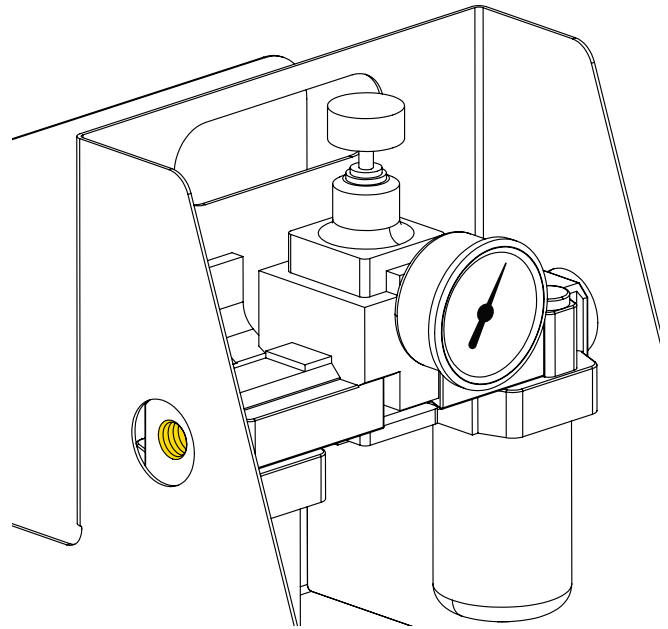

Fig. 2

4. Install the supplied male quick coupler into the outlet port.
5. Connect the air hose to the male quick coupler.

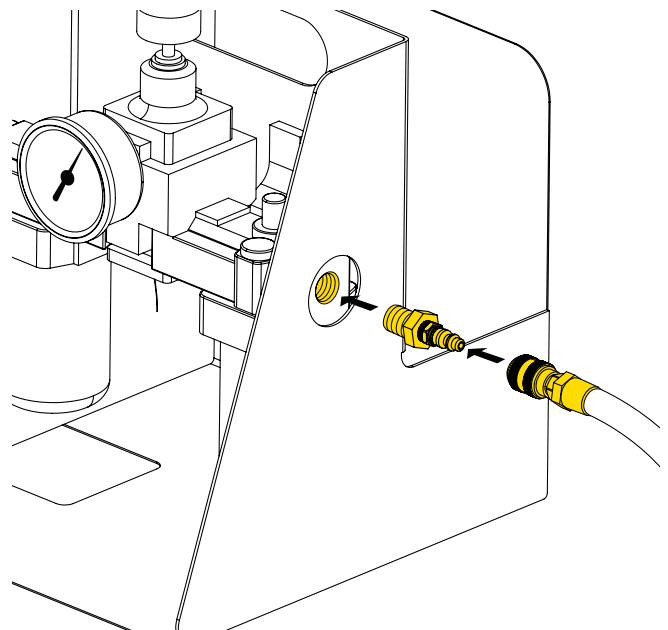

Fig. 3

PTW Series Pneumatic Torque Wrench

6. Connect the air hose to the tool.

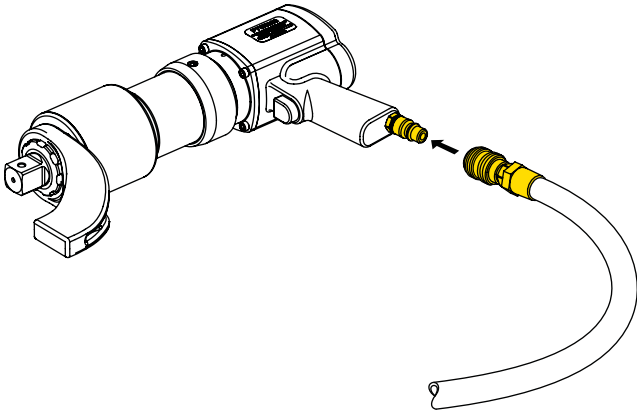

Fig. 4

7. Install the reaction arm onto the tool. Tighten the setscrew to secure it on the tool.

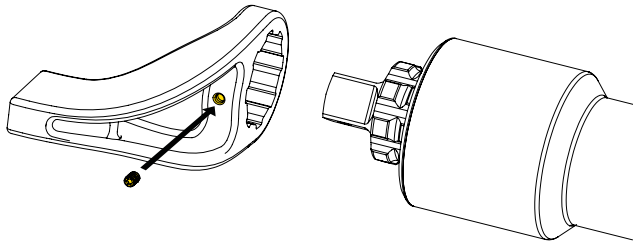

Fig. 5

NOTICE: Thread the setscrew in just deeply enough to catch the retaining shoulder. Bottoming out the screw can cause thread damage during operation, making it difficult to remove.

8. Turn on the air supply.

4 OPERATION



WARNING: Before using the tool, inspect the tool, reaction arm, air hoses and Filter/Regulator/Lubricator (FRL) for any cracks, wear or other damage. Immediately replace any worn or damaged parts with genuine Enerpac parts before using the tool.

1. To rotate the tool clockwise, move the lever to the “F” position. To rotate the tool counterclockwise, move the lever to the “R” position. There are 3 speeds for each direction.

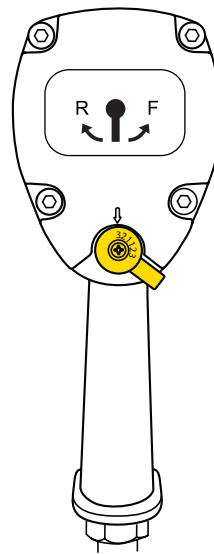

Clockwise
Rotation

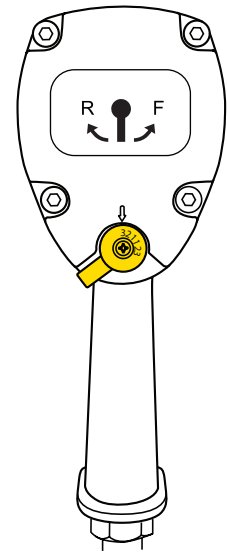

Counterclockwise
Rotation

Fig. 6

PTW Series Pneumatic Torque Wrench

- The torque output of the tool is set by adjusting the air pressure using the regulator on the FRL.

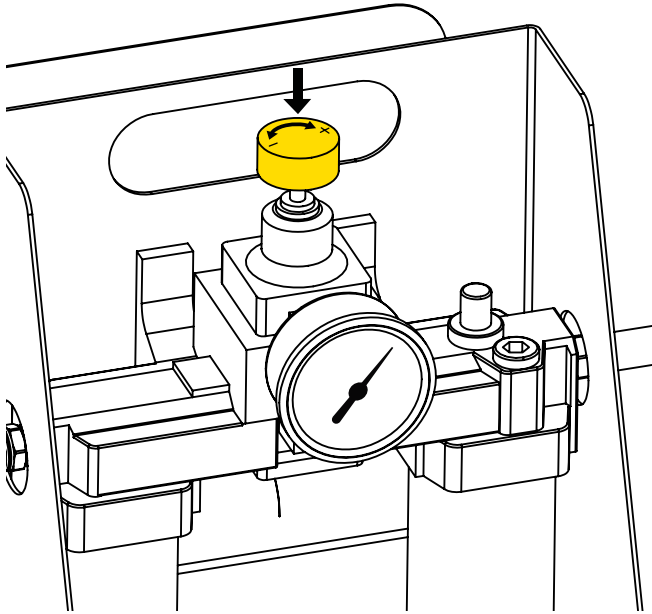

Fig. 7

- Determine the correct air pressure for the desired torque setting by using the chart from the most recent calibration. A factory calibration chart is provided by Enerpac in the tool case.
- Adjust the lever on the back of the tool indicated in Fig. 6 so the tool is set to the highest speed and direction of rotation.

The tool calibration chart provided by Enerpac for this tool was produced with the tool on the highest speed. Tool performance in this speed will most closely reproduce the pressure/torque ratio listed in this chart.



WARNING: Do not attempt to operate the tool at pressures exceeding the torque ratings from the supplied chart.

NOTE: For an accurate torque value, the air pressure must be adjusted with the tool free-running (rotating freely, not under load).

- Fully depress the trigger of the tool and adjust the regulator to the correct pressure while the tool is free-running.

- Make sure the appropriate reaction arm is installed onto the tool.
- Determine the correct size socket and install it on the square drive. It is recommended that the socket be pinned onto the square drive.
- Install the socket onto the fastener and rotate the body so the reaction arm is positioned against the reaction point.



WARNING: To prevent serious crushing injury, always keep all body parts away from the reaction point when the tool is in use.



CAUTION: When in operation, the reaction arm rotates in the opposite direction of the square drive. Always make sure the reaction arm is positioned against a solid fixed object.

NOTE: For clockwise rotation, the adjustment lever is set to the “F” position.

- Fig. 8 shows the position for the reaction arm when the square drive rotates clockwise.

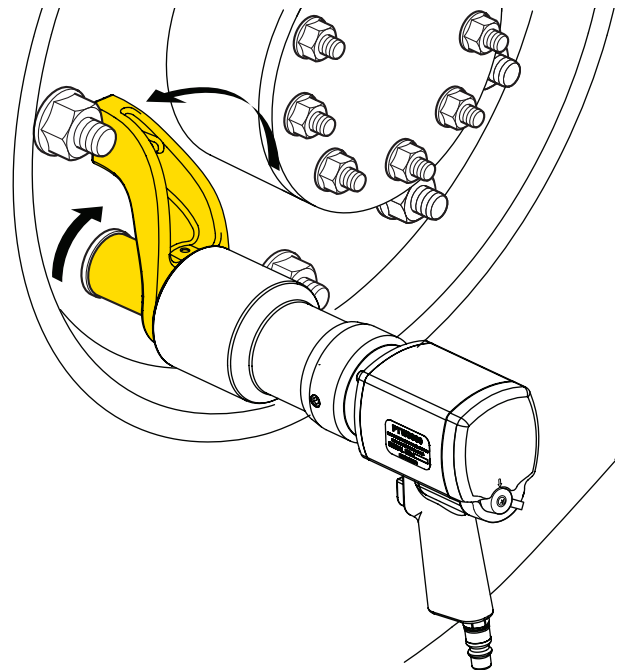

Fig. 8

PTW Series Pneumatic Torque Wrench

NOTE: For counterclockwise rotation, the adjustment lever is set to the “R” position.

10. Fig. 9 shows the position for the reaction arm when the square drive rotates counterclockwise.



DANGER: Do not place any part of the body between the reaction arm and the reaction point.

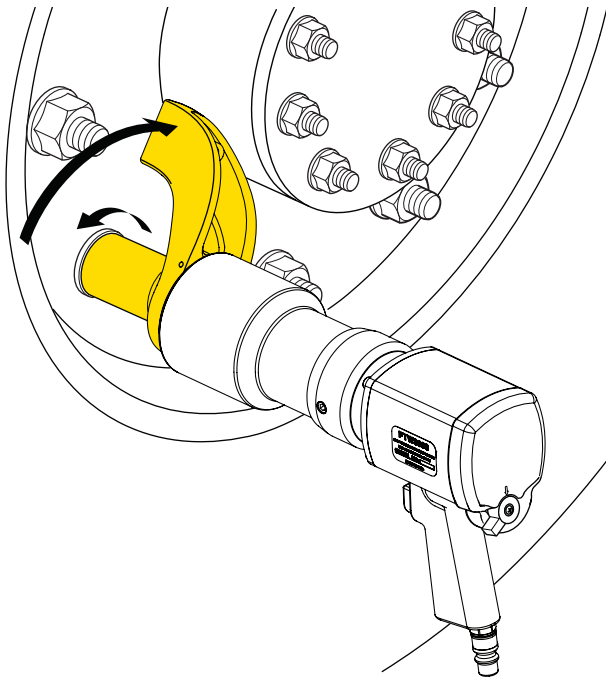

Fig. 9

11. To tighten a fastener (or to apply torque in the clockwise direction): Be sure the adjustment lever is set to the “F” position, and that the reaction arm is positioned as shown in Fig. 8. Then, fully depress the trigger, and keep it depressed until the wrench stalls.

NOTICE: If the trigger is released before the wrench stalls, the desired torque will not be applied to the fastener. Do not repeatedly depress and release the trigger while tightening a fastener, as this could result in the incorrect torque being applied.

12. To loosen a fastener (or to apply torque in the counterclockwise direction): Be sure that the adjustment lever is set to the “R” position and that the reaction arm is positioned as shown in Fig. 9. Then, fully depress the trigger and keep it depressed until the fastener loosens.

13. After tightening or loosening is completed, release the trigger and remove the tool from the fastener. In some cases, it may be necessary to briefly operate the tool in the opposite direction to release the counter torque load from the reaction arm.

14. When finished using the tool, turn off the air supply, disconnect the hoses, remove the reaction arm and store the tool in the case.

PTW Series Pneumatic Torque Wrench

5 MAINTENANCE

NOTICE: Failure to keep the air motor properly lubricated can cause a reduction in output torque.

A constant source of clean and lubricated air is required to ensure proper operation of the air motor's internal components.

Periodically check the oil level in the FRL lubricator bowl and add oil if low. Check the oil drip rate and readjust drip speed if too slow or too fast.

NOTICE: Failure to maintain proper lubricator oil level and drip rate will result in reduced output torque and possible air motor failure.

Drain the water separator bowl as needed. Clean and/or replace filter elements inside the bowl.

6 TROUBLESHOOTING

Symptom	Possible Cause	Solution
Tool is not producing required torque.	Inadequate incoming air.	Check pressure setting on FRL.
	Inadequate lubrication.	After shutting down the FRL, remove the air fitting coupler from the tool. Add 1/2 teaspoon of oil and install the air fitting coupler.
	Motor contamination.	Contact Enerpac Service Center.
Noticeable changes in sound level during operation from one fastening to the next.	Inadequate lubrication.	Increase the drip rate for the FRL. Recheck and reset drip rate if necessary.
Motor turns but there is no torque output.	Broken square drive.	Contact Enerpac Service Center.
	Internal gearbox failure.	
Noisy gearbox.	Gearbox failure.	Contact Enerpac Service Center.

PTW Series Pneumatic Torque Wrench

7 TECHNICAL SPECIFICATIONS

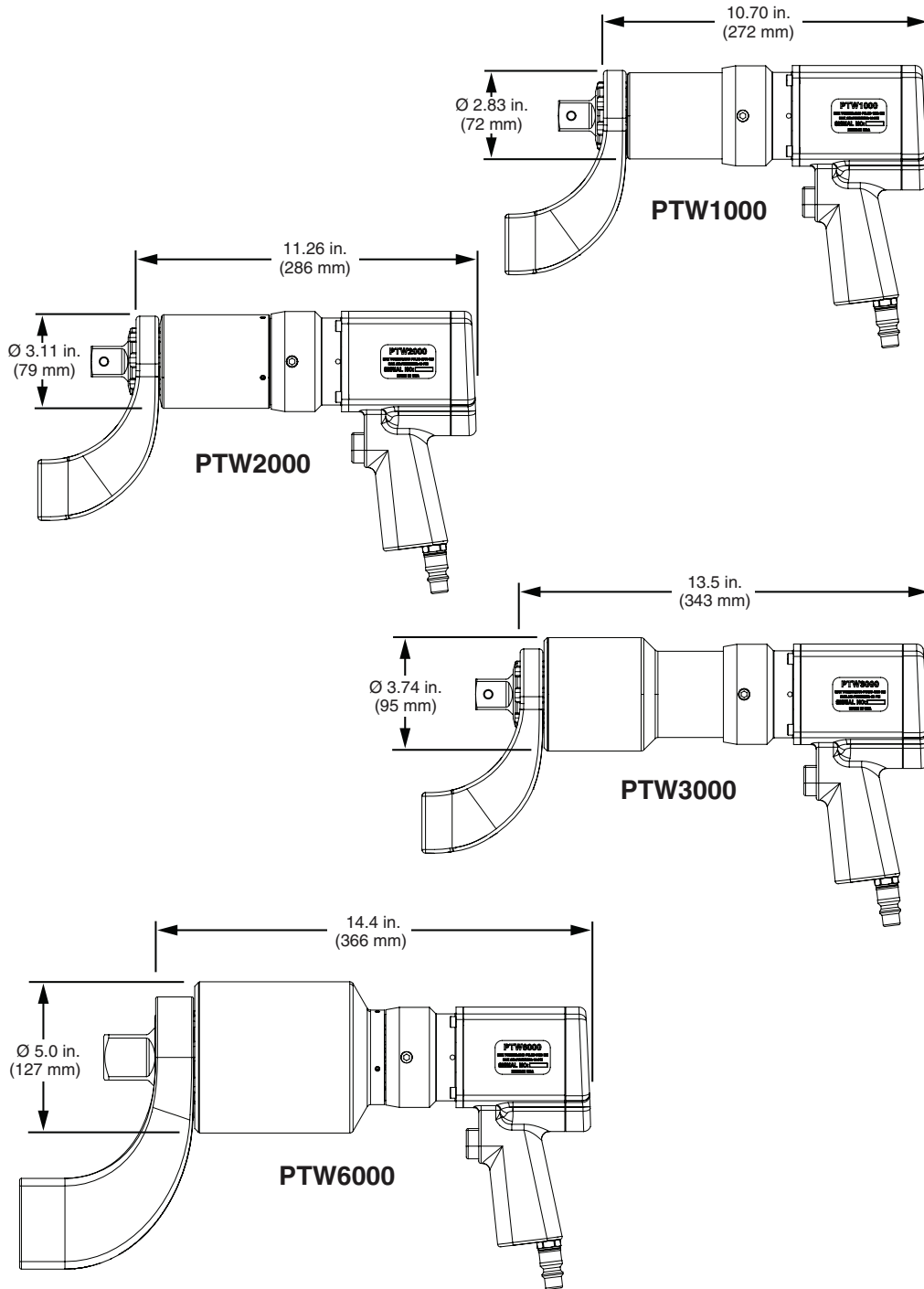

Tool Model	Tool lb (kg)	Supplied Reaction Arm lb (kg)	Minimum Output ft-lb (Nm)	Maximum Output ft-lb (Nm)
PTW1000	18 (8.16)	2.85 (1.29)	300 (407)	1,000 (1,356)
PTW2000	19.5 (8.85)	2.85 (1.29)	500 (678)	2,000 (2,712)
PTW3000	23 (10.43)	2.85 (1.29)	900 (1,220)	3,000 (4,067)
PTW6000	39 (17.69)	7.75 (3.52)	1,300 (1,763)	6,000 (8,135)



www.enerpac.com