

L4220 Rev. A 08/17

For Date Codes Beginning with the Letter "A" or "B"

Troubleshooting and Repair:

English	13-15	Português	N/A
Français	N/A	Suomalainen	N/A
Deutsch	N/A	Norsk	N/A
Italiano	N/A	Svensk	N/A
Español	N/A	中文	N/A
Nederlands	N/A	日本語	N/A

To Protect Your Warranty, Use Only Enerpac Hydraulic Oil.

Enerpac recommends that all kit components be installed to insure optimum performance of the repaired product.

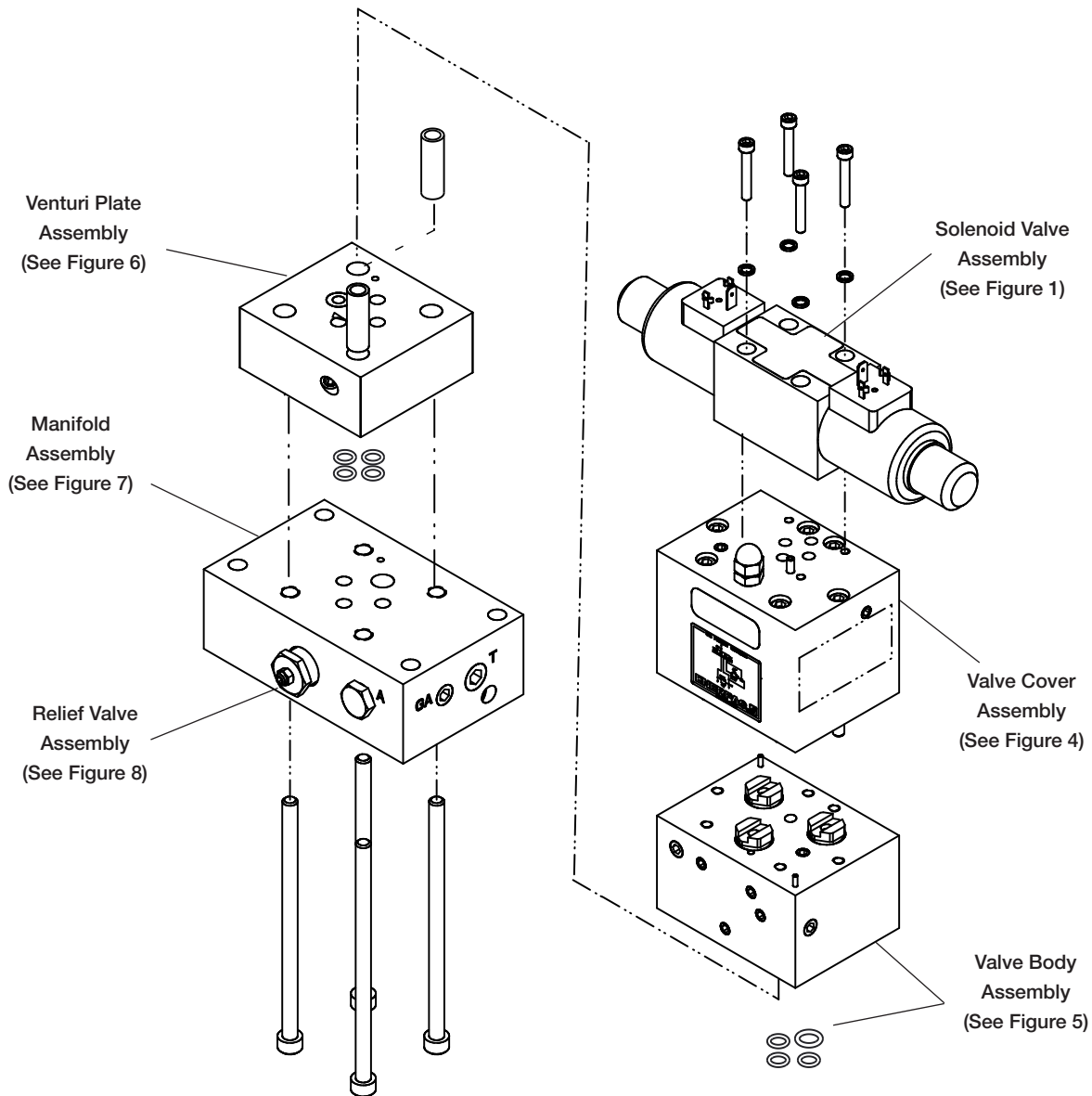
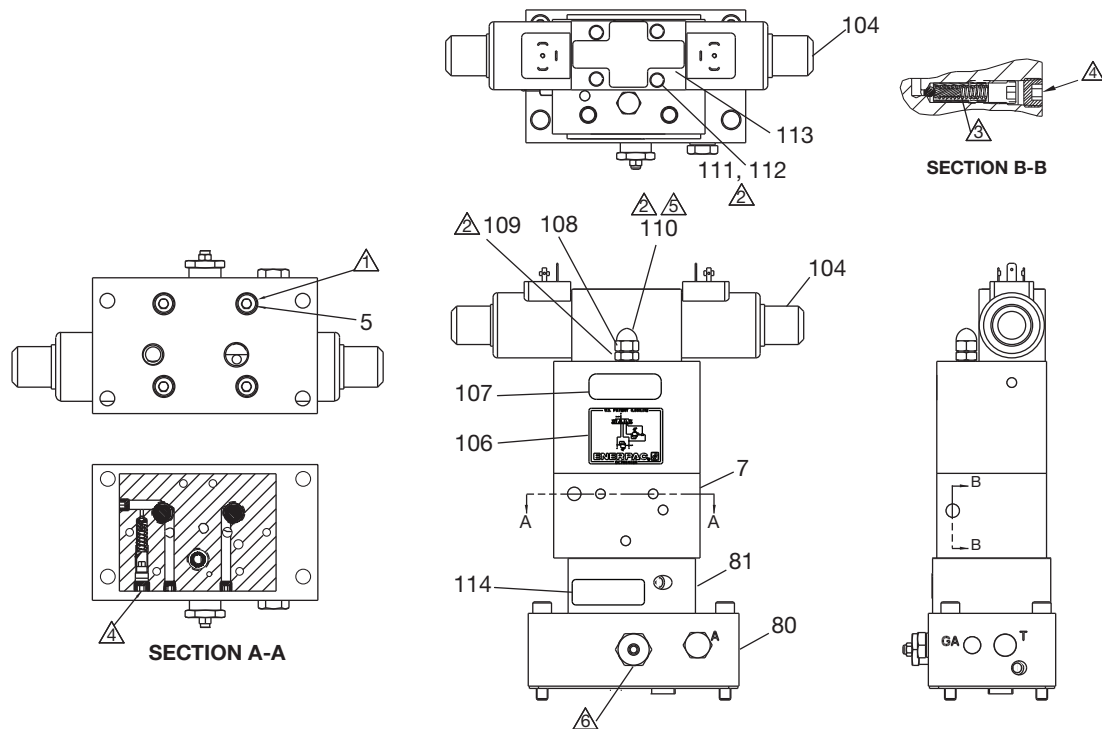

Figure 1, Electric Valve Components, VE33VAC



NOTES:

- ⚠ Torque to 22-25 Ft-lbs [30-34 Nm].
- ⚠ Torque to 5-6 Ft-lbs [7-8 Nm].
- ⚠ Pilot pressure relief to be set for 2200 psi \pm 200 [151 bar \pm 14]. Bottom set screw onto sleeve. or stop. Unscrew set screw one (1) complete revolution, before setting pressure limit. (Refer to paragraph 2 of *Reassembly* section, and paragraph 2 of *Adjustments* section, at the end of this manual)
- ⚠ For .125-27 pipe plugs torque to 10-12 ft-lbs [14-16 Nm].
- ⚠ Adjust Item 35 (see Fig. 4) to close at 1200-1400 psi [82-96 bar] followed by locking in place with Item 109 and Item 108. Pilot pressure can drop to but maintain a minimum of 850 psi [58 bar]
- ⚠ Standard user adjustable relief valve to be set at 10,000 psi +500/-0 [700 bar +3.5/-0].

Figure 2, Three-Way Electric Valve, VE33VAC

Repair Parts List for Figure 2							
Item	Part Number	Qty.	Description	Item	Part Number	Qty.	Description
5	CBE845028-1A	4	SHCS, M8 X 90	108	BL30156	2	Copper Gasket
7	See Figure 5	1	Valve Body Assembly	109	B1006124	1	Jam Nut
32	See Figure 4	1	Valve Cover Assembly	110	L342055	1	Acorn Nut
80	See Figure 7	1	Manifold Assembly	111	B1331028X	1	SHCS, #10-24 UNC
81	See Figure 6	1	Venturi Plate Assembly	112	B1086066	4	Lock Washer
104	DC5142660	1	Solenoid Valve Assembly (24 VDC)	113	DC6359226	1	Label, 24 VDC
106	DC7864026	1	Decal, Valve (VE33VAC)	114	DD6801026	1	Decal, Warning
107	CH272026	1	Decal, Caution				

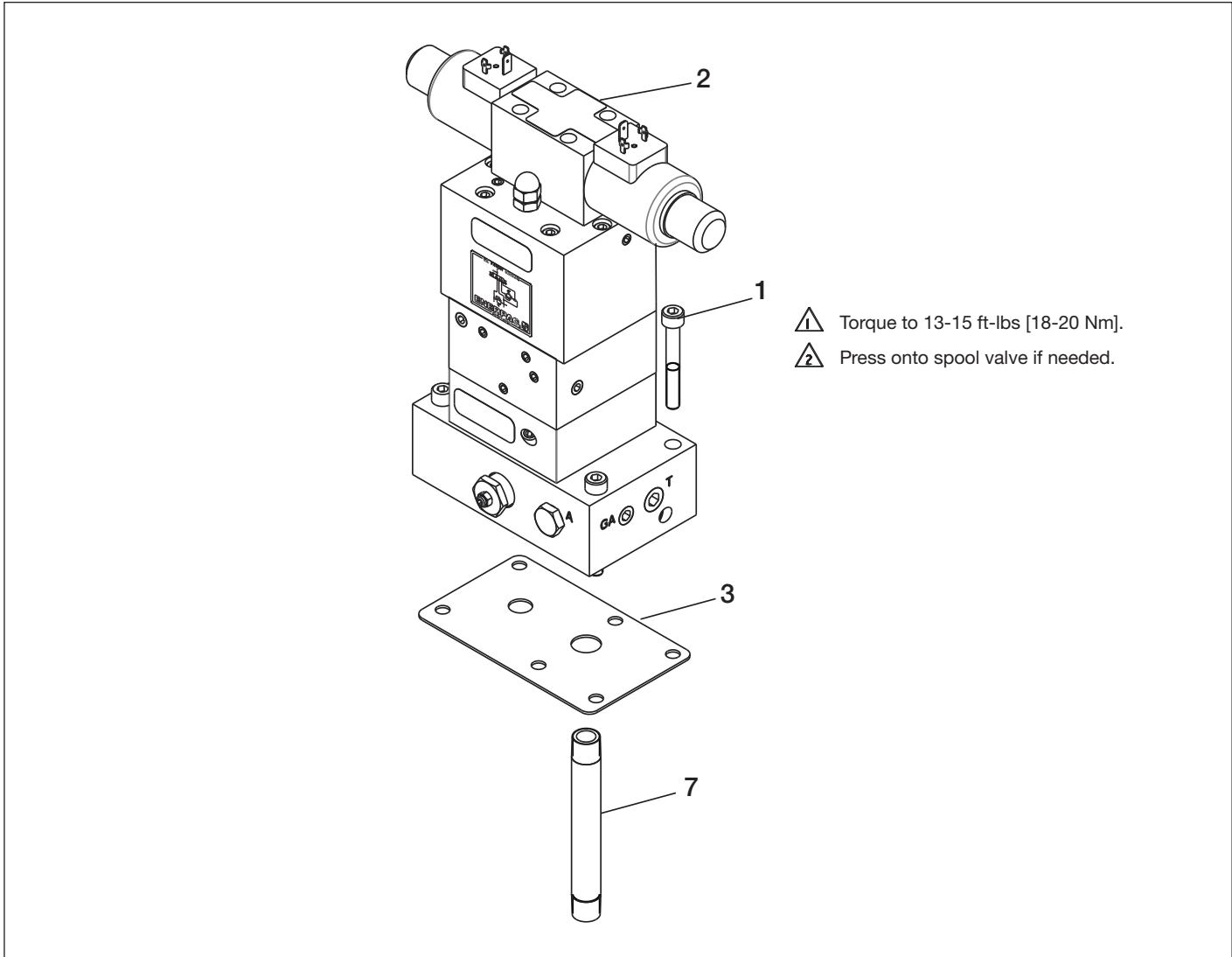
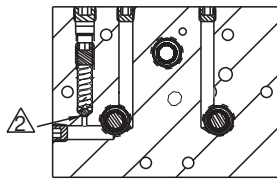
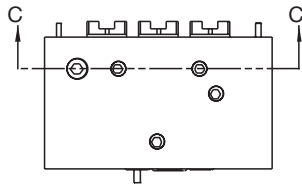
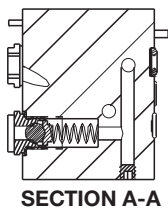
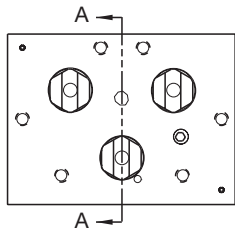
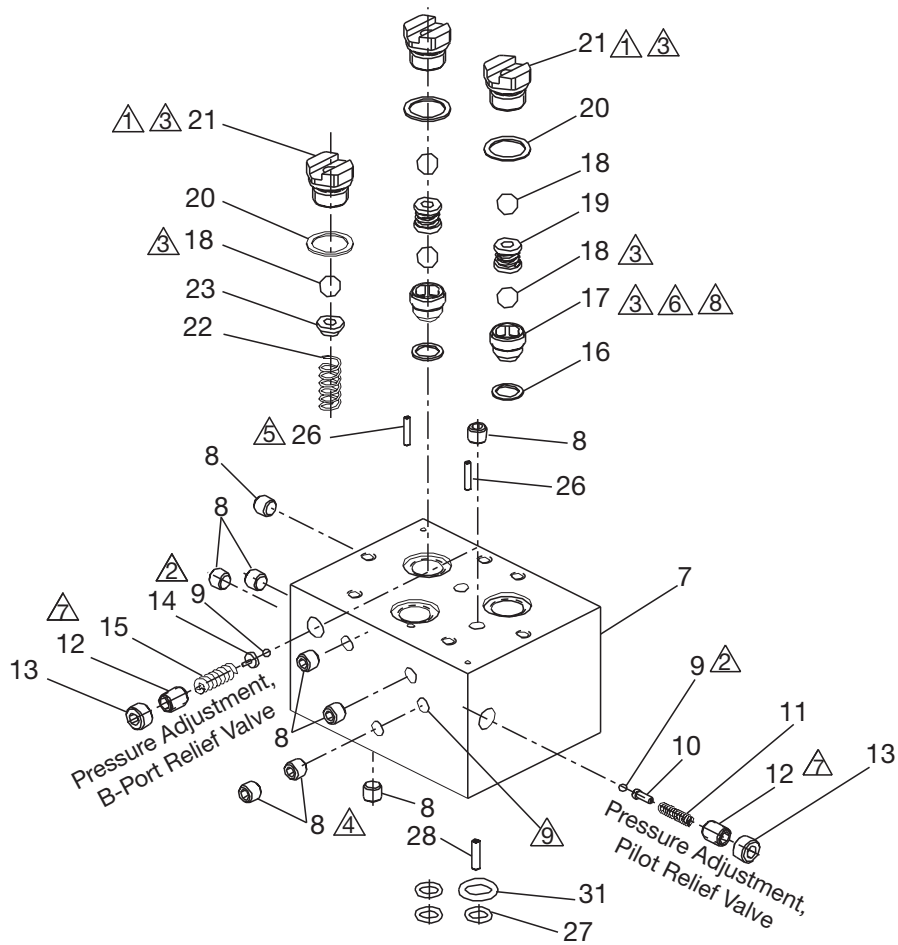

Figure 3, Electric Valve Mounting Hardware, Gasket, and Return Pipe, VE33VAC

Repair Parts List for Figure 3			
Item	Part Number	Qty.	Description
1	CBE837028-1A	4	SHCS, M8 X 60
3	★ DC9356037	1	Gasket
7	DC2749768	1	Return Pipe
★ Item included in Repair Kit VE43K1.			

Repair Parts List for Figure 4			
Item	Part Number	Qty.	Description
32	DC5894190	1	Cover, Block
33	DC6794245	1	Flush Plug 1/4"
34	DC6792245	6	Flush Plug 1/16"
35	■ BF3824027A	1	Set Screw, Pilot Adjust
36	■ DD1327900	1	Spacer, Ball Guide Assy.
37	■ DC8498110	1	Spring
38	● DA983950	1	Pilot Piston Assy. (valves mfg. before 10/2008)
38A	★ B1214203	1	O-Ring, 1.25" O.D. x .139 x.s.
38B	★ B1214564	1	Backup Ring
38	■ DD1190950	1	Pilot Piston Assy. (valves mfg. after 10/2008 - includes items 38C and 38D)
38C	★ B1024203	1	O-Ring, 1.25" O.D. x .070 x.s.
38D	★ B1024564	1	Backup Ring
39	DA982950SR	2	Directional Piston Assy. (includes items 39A and 39B)
39A	★ B1214203	2	O-Ring, 1.25" O.D. x .139 x.s.
39B	★ B1214564	2	Backup Ring
40	★ BL10952	2	Spring
41	★ B1010803	1	O-Ring, 0.38" O.D. x .070 x.s.
	★ B1011803	1	O-Ring, 0.44" O.D. x .070 x.s.
42	★ B1026803	3	O-Ring, 1.38" O.D. x .070 x.s.
43	CCE643028-1A	6	SHCS - M6 x 1.0 x 80 mm
44	B1051057	1	Spring Pin
<p>■ Items included in Repair Kit DD1190950SR. (Use kit to upgrade valve from date code "A" to date code "B".)</p> <p>★ Items included in Repair Kit VE43K1.</p> <p>● Pilot piston assembly DA983950 is no longer available. If replacement is required, order Repair Kit DD1190950SR. Install new piston DD1190950 and all other kit parts as a complete set.</p>			



SECTION C-C

Notes:

- △ Torque to 27-35 Ft-lbs [36-47 Nm].
- △ Coin ball seat at 130 psi [9,0 bar] on a 10-ton press or 260 psi [17,9 bar] on a 5-ton press.
- △ Coin ball seat at 300 psi [20,6 bar] on a 10-ton press or 600 psi [41.3 bar] on a 5-ton press.
- △ Torque Item 8 to 10-12 ft-lbs [14-16 Nm].
- △ Press pin, Item 26, into block, Item 7.
- △ Torque to 20-25 Ft-lbs [27-34 Nm].
- △ Refer to *Adjustments* section of this manual for final setting of Item 12**.
- △ Assemble Item 17 using tool No. TXK200466-3.
- △ This plug only to be hand-tight + one revolution.

Figure 5, Valve Body Assembly

Repair Parts List for Figure 5			
Item	Part Number	Qty.	Description
7	DC5906190	1	Valve Body
8	DC6792245	9	Flush Plug 1/16"
9	★ B1003016	2	Ball
10	★ DD1707013	1	Guide**
11	★ DD1684110	1	Spring**
12	★ DC6531028	1	Screw**
13	DC6793245	2	Flush Plug 1/8"
14	★ K1013	1	Ball Guide
15	★ BL10968	1	Spring
16	★ BL30156	2	Gasket
17	★ CW182290	2	Lower Seat
18	★ B1010016	5	Ball, .34" diameter
19	L843186	5	Spacer
20	★ P182167	3	Gasket
21	★ CW181290	3	Upper Seat
22	★ L848110	1	Spring
24	★ DC6280110	2	Spring
26	B1036057	2	Spring Pin
27	★ B1011803	3	O-Ring, .44" diameter O.D.
28	B1051057	1	Pin
31	★ B1111803	1	O-Ring, .62" diameter O.D.
★ Items included in Repair Kit VE43K1.			
<p>** NOTE: The sleeve limits the setting of items 10, 11, 12. See the notes in Figure 2 for additional relief valve setting information. Also refer to the <i>Adjustments</i> section at the end of this manual.</p>			

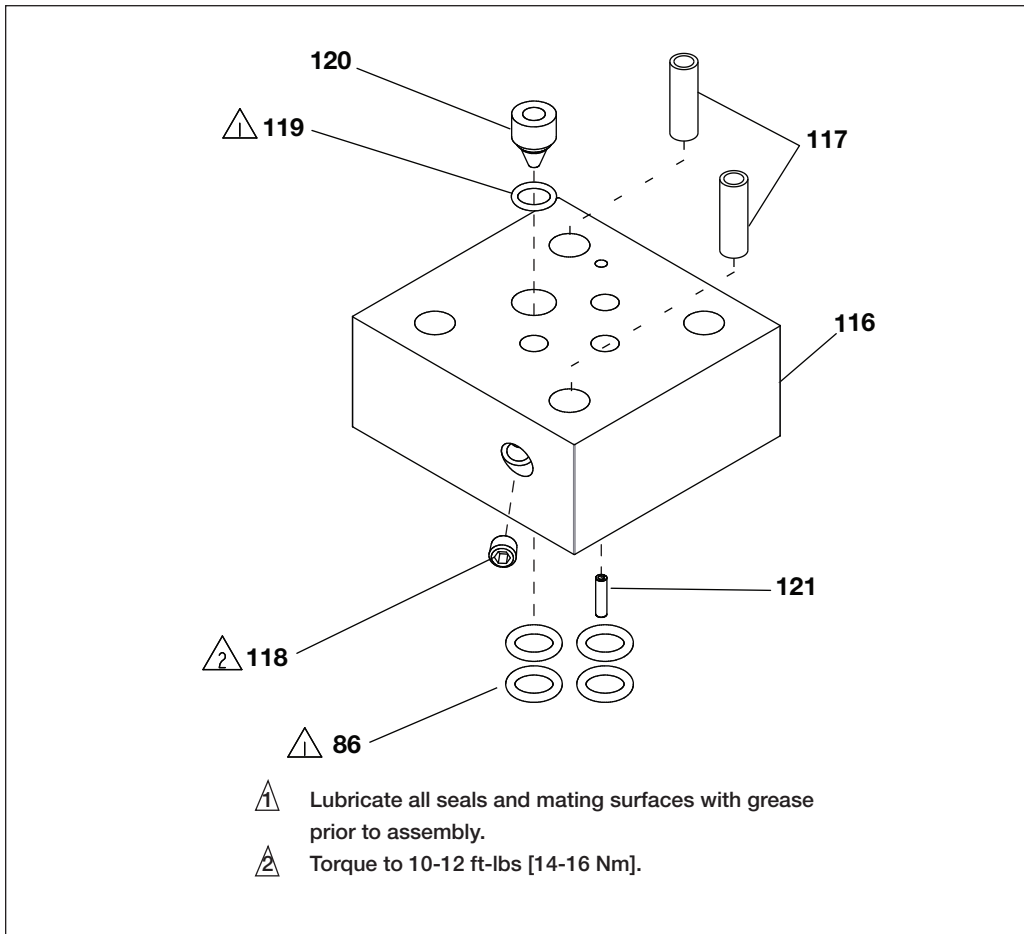

Figure 6, Venturi Plate Assembly

Repair Parts List for Figure 6			
Item	Part Number	Qty.	Description
86	★ B1111803	4	O-Ring
116	★ DC7850190	1	Venturi Plate
117	DD6677225	2	Insert
118	★ DC6792249	1	Plug
119	★ B1007503	1	O-Ring
120	★ DD6612828	1	Nozzle
121	★ B1051057	1	Spring Pin
★ Items included in Repair Kit VUV6MSR.			

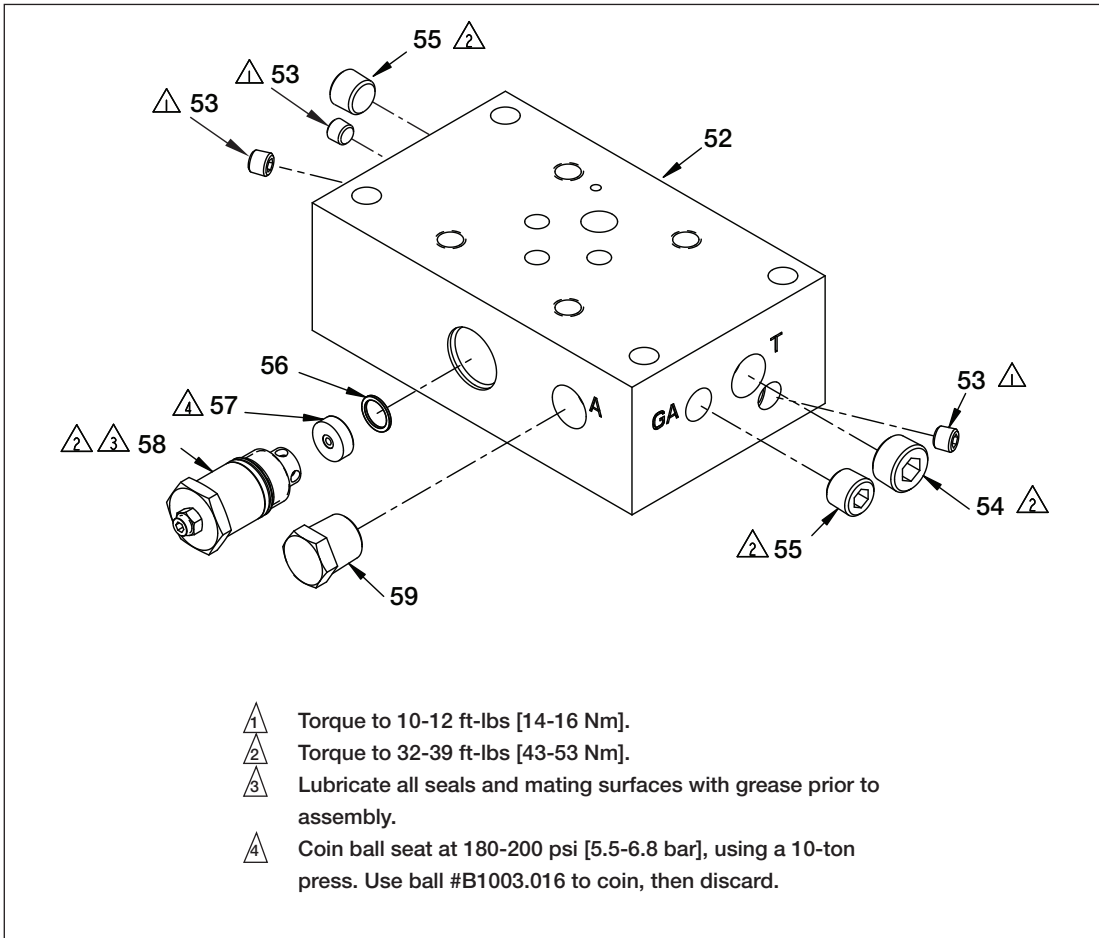

Figure 7, Port Manifold Assembly, DC6245950SR, VE33VAC

Repair Parts List for Figure 7			
Item	Part Number	Qty.	Description
52	★ DC6303038	1	Manifold
53	★ DC6792245	4	Flush Plug 1/16"
54	★ DC6795245	1	Flush Plug 3/8"
55	★ DC6794245	2	Flush Plug 1/4"
56	★ P20037	1	Gasket
57	★ DC5124290	1	Seat
58	★ DC5139900SR	1	Relief Valve Assembly
59	★ R515245-2	1	Plug
★ Items included in Repair Kit DC6245950SR.			

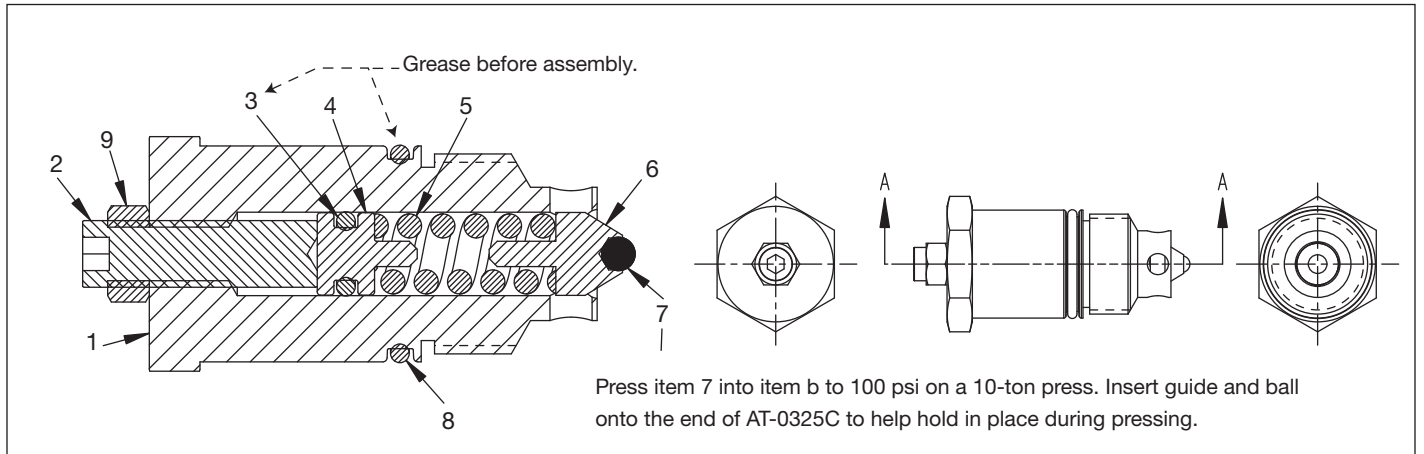

Figure 8, User-Adjustable Relief Valve Assembly, DC5139900SR

Repair Parts List for Figure 8			
Item	Part Number	Qty.	Description
1	★ DC5138190	1	Body
2	★ BC2512027FX	1	Set Screw
3	★ B1003503	1	O-Ring
4	★ DC5127007	1	Plug
5	★ A8126110	1	Spring
6	★ DC5125013	1	Guide
7	★ B1003016	1	1/8 Dia. Ball
8	★ B1223503	1	O-Ring
9	★ B1001122	1	Lock Nut
	★▲ DC5124290	1	Seat (not shown)
	★▲ P20037	1	Gasket (not shown)
★ Items included in Repair Kit DC5139900SR.			
▲ See Figure 7, Items 56 and 57.			

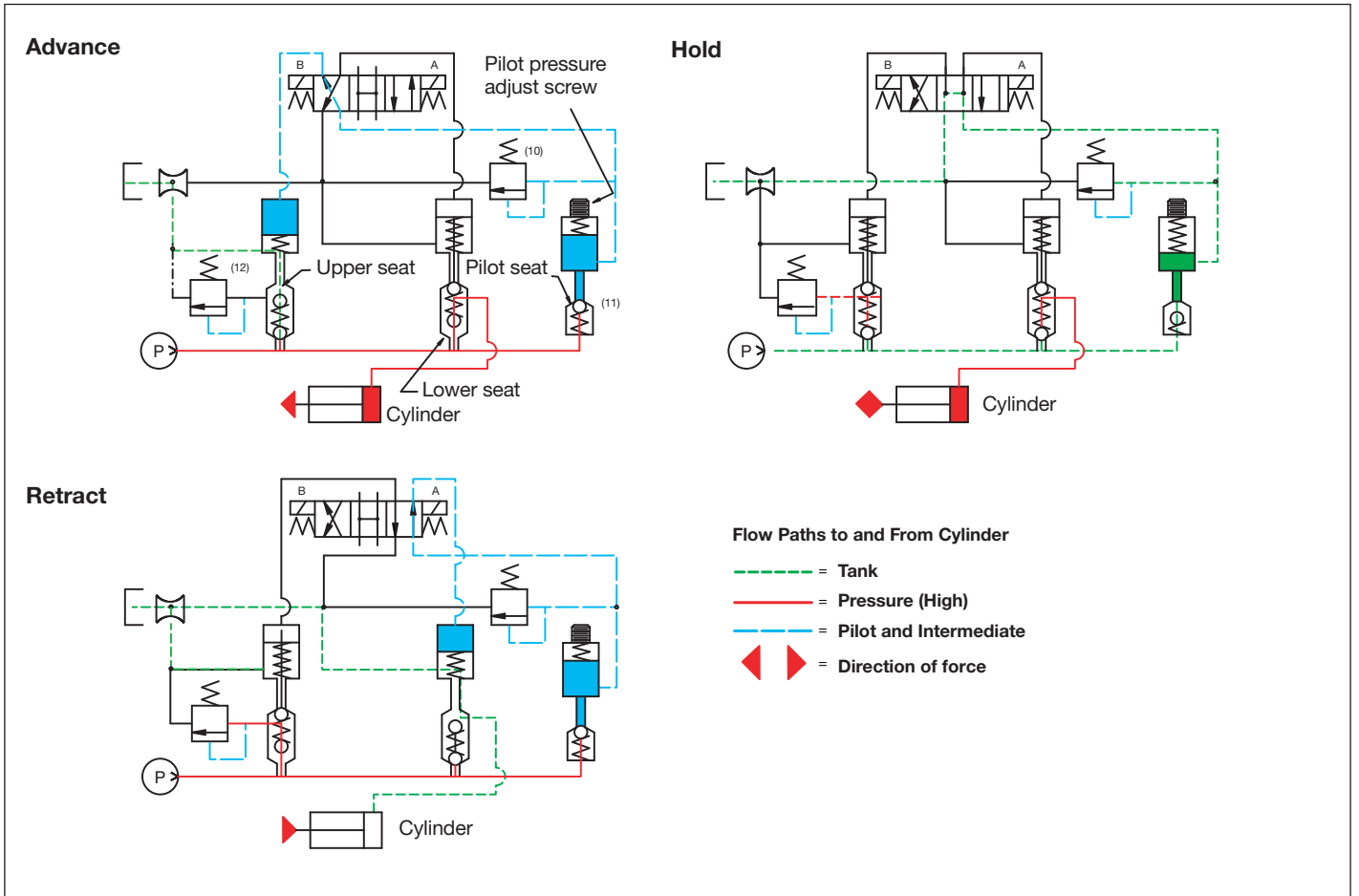

Figure 9, Electrical Diagrams, VE33VAC (For Troubleshooting Purposes Only)

Solenoids		
Position	A	B
Advance	De-energized	Energized
Retract	Energized	De-energized
Hold	De-energized	De-energized
Settings		
Adjustment Item	Pressure	
(*) Pilot relief pressure	2000-2400 psi [137-165 bar]	
(♦) Pilot piston pressure	1200-1400 psi [82-96 bar]	

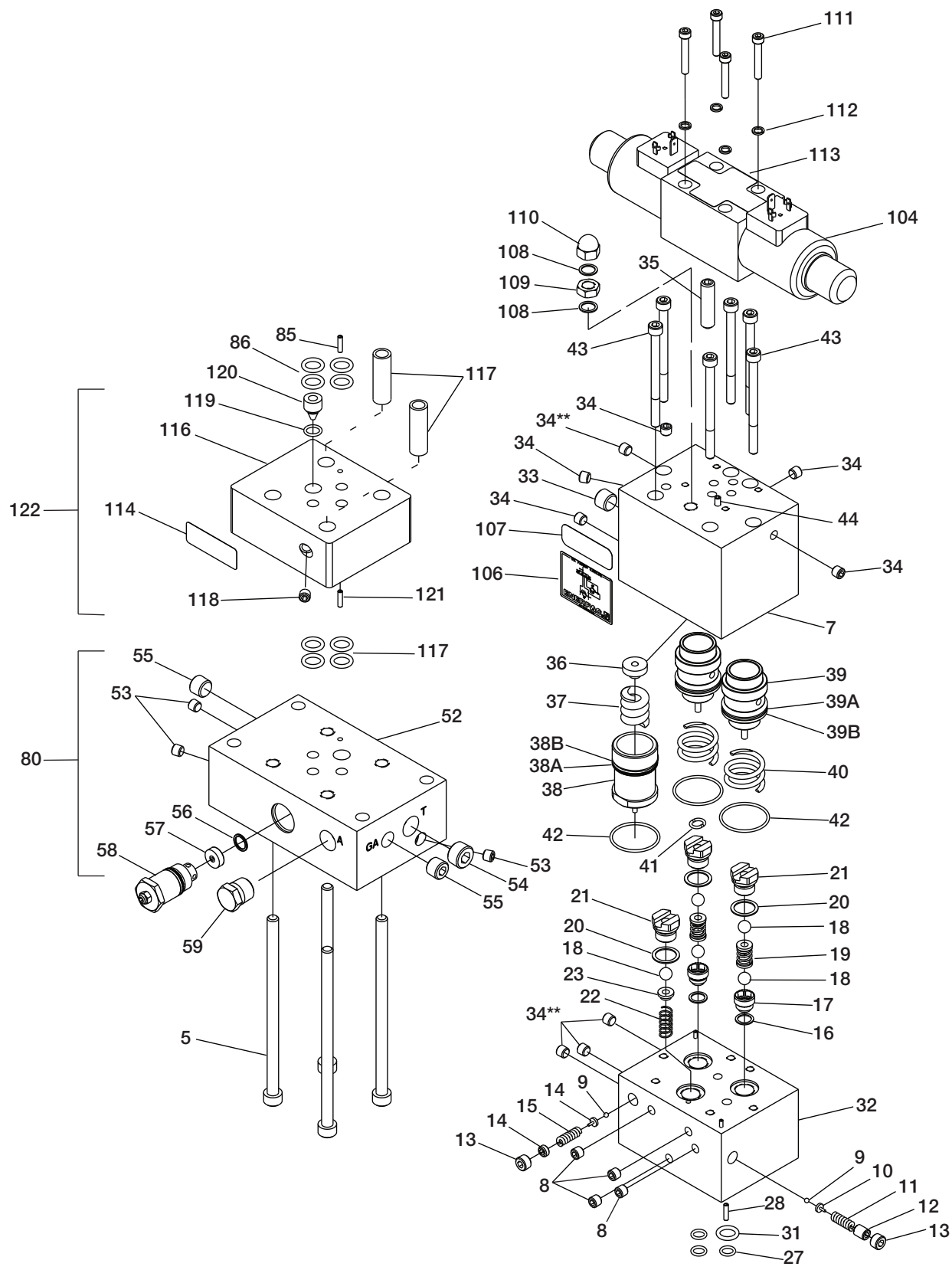

Figure 10, Electrically-Operated, Vacuum Assisted Control Valve Assembly, VE33VAC

TROUBLESHOOTING AND REPAIR OF ELECTRIC VALVE, VE33VAC

In diagnosing malfunctioning valves, certain symptoms may be common not only to valves, but often to hydraulic equipment in general. Before repairing the valve, mount a VM32 valve on the pump and verify that the problem is not with the pump.

TROUBLESHOOTING:

1. To assist in becoming familiar with the function and usage of the valve, please refer to Figures 9 and 10.
2. Check electrical operation of valve. Make certain pushbutton control station is in correct working order. Check spool valve for “clicking” sound that indicates operating solenoids.
3. Make certain that pilot pressure has been correctly set, or can be adjusted, and that the valve has been checked for external oil leakage.
4. Inability to obtain any pressure may be the result of damaged connector seals, failed relief valve components (items 9, 14, 15), sticking solenoid spool (item 104), or the pilot pressure setting is too low (less than 500 psi [34 bar]).
5. Pressure leaks that are consistent and increase proportionally with increasing pressure ranges are usually the result of leaking gaskets or threaded surfaces such as NPTF fittings or plugs.
6. Ball seat leakage is often erratic and intermittent and is caused by contaminants trapped on the sealing edge. Over time, as wear occurs, these seats need to be replaced.
7. If the valve malfunction is identical in both directions, check the pilot pressure setting by inserting a 0-5000 psi [0-344 bar] gauge in the port labeled “pilot pressure” on the side of the valve. Advance the valve and check that the pilot pressure is between 1200-1400 psi [82-96 bar] and adjust the pilot pressure adjustment screw (item 35) accordingly to either increase or decrease the pressure setting. If no improvement is noticed, replace the spring (item 37), pilot seat (item 21), and copper gasket (item 20).
8. If the pilot setting cannot be adjusted down, it can indicate the O-ring and backup ring are installed on the wrong side of each other on item 38, or indicates a severe leakage in the pilot seat (item 21) or a broken spring (item 22). Replace parts immediately.
9. If the valve fails to build to maximum pressure, the pilot pressure may be too low. Low pilot pressure may be caused by leakage through the spool valve or a leaking relief ball seat (item 9) in the valve body (item 7), or the pilot setting is too low and needs to be adjusted (see step 7, above).
10. If the valve builds pressure simultaneously in both directions, this may be the result of a broken pin in either one or both of the directional piston assemblies (item 39), and/or the pilot piston (item 38), or the pilot pressure setting (item 35) is too low, or that the pilot spring (item 37) has broken. Either readjust the pilot setting or replace parts immediately.
11. If the valve fails to change direction immediately, this may be due to worn springs (item 19) between the ball directional circuits, or a problem with the directional pistons (item 39), either a broken pin or failed seal. Replace parts immediately.
12. If the cylinder will not build pressure either in the advance or retract position, check the pilot pressure setting (set between 1200-1400 psi [82-96 bar]). Another possible cause is the upper seat and/or the pilot seat is worn and must be replaced. If the cylinder creeps in the “Neutral” position or “Hold” position, this may suggest a worn upper or lower valve seat or spring (item 19) that must be replaced.
13. If the cylinder is hung-up in either the advance or retract position, the problem is usually a symptom of contaminated hydraulic oil. The system should be drained and refilled with fresh Enerpac hydraulic oil. The spool valve should then be centered manually by depressing the pin actuator on either side of the spool valve. Now press the “up” arrow and “down” arrow several times checking the valve operation and cylinder movement. Another cause might be that the pilot pressure setting is too high (greater than 1400 psi [96 bar]), in which case the pilot pressure relief valve must be reset to 2200 psi [151 bar] ± 200 psi [± 14 bar].
14. Slow retract speed of a single-acting cylinder may be because the return pipe (item 75) is not installed. Make sure that item 75 is installed to the tank return port under the valve manifold (item 52). Using a hose with a larger inside diameter or using a shorter length hose (between the valve and the cylinder) will improve cylinder retract speed.

DISASSEMBLY:

1. Remove solenoid valve assembly (item 104) by removing the 4 screws (item 111) and lockwashers (item 112). **NOTE:** Do not disassemble solenoid valve!
2. Disassemble the valve assembly by first removing the acorn nut (item 110), lock nut (item 109), copper gaskets (item 108), adjustment screw (item 35), and 6 screws (item 43). Separate cover (item 32) from body (item 7). Remove seals (items 42, 41), directional springs (item 40) from bottom of cover. Remove the pilot piston assembly (item 38), spring (item 37), and spacer (item 36). Inspect all seals for damage. If in doubt replace with new items supplied with repair kit.
3. Disassemble the advance and retract directional pistons (item 39).
4. Disassemble the pilot section by removing the pilot seat (item 21), copper gasket (item 20), ball (item 18), spacer (item 23), and spring (item 22). Disassemble the advance and retract sections by removing the upper seats (item 21), copper gasket (item 20), ball (item 18), spring and spacer assembly (item 19), ball (item 18), and lower seat (item 17). Use special tool No. TXK200466-3 and copper gasket (item 16). Discard used copper gaskets and replace with new items supplied in repair kit.
5. Disassemble the pilot relief section by removing the plug (item 13), adjustable screw (item 12), spring (item 11), guide (item 10), and ball (item 9).
6. Disassemble the B port relief section by removing the plug (item 13), adjustment screw (item 12), spring (item 15), ball guide (item 14), and ball (item 9).
7. It is not necessary to remove the numerous pipe plugs found on the cover and body unless contamination is trapped within the parts and needs to be flushed out. Replace with new items supplied in repair kit.

8. Disassemble the manifold assembly (item 52) from the venturi plate assembly (item 122) by removing the 4 screws (item 5). Inspect the seals (item 117) and replace if necessary.
9. Remove the venturi plate assembly (item 122). Inspect the seals (item 86) and replace if necessary.

REASSEMBLY:

When assembling, use new parts supplied in repair kit:

1. Clean valve body and inspect all components. Check for worn or damaged ball seats (items 17, 21), and/or broken or weak springs (items 15, 19, 22, 37, 40). Inspect relief ball seats in valve body (item 7). Replace if necessary.
2. Carefully reseal small ball (item 9) in body (item 7) using a TXK200468 and 10-ton press. All seats must be seated by placing the ball on the seat and pressing to 130 psi [9.0 bar]. Replace guides (item 14, 10), springs (item 15, 11) and adjustment screws (item 12). Screw the adjustment screw (item 12) in the pilot relief valve (items 9, 10, 11) until it bottoms out on sleeve or step, then unscrew one (1) complete revolution. Do not install pipe plug (13) at this time as adjustments to the reliefs will be made during testing of the valve. The "B" port relief will be adjusted later.
3. Using the balls (item 18), coin the seats (item 17, 21) at 300 psi [20.6 bar] on a 10-ton press or 600 psi [41.3 bar] on a 5-ton press.
4. Assemble the advance and retract piston sections by inserting the copper gasket (item 16) onto the lower seat (item 17). Torque the lower seats to 20-25 ft-lbs [27-34 Nm] using tool No. TXK200466-3. Install balls (item 18), spring and spacer assemblies (item 19), balls (item 18), copper gasket (item 20), and upper seat (item 21). Torque upper seat (item 21) to 27-35 ft-lbs [36-47 Nm].
5. Assemble pilot pressure adjustment spring (item 22), spacer (item 23), ball (item 18), gasket (item 20), and seat (item 21). Torque seat (item 21) to 27-35 ft-lbs [36-47 Nm].
6. Install insert (item 117) in any two thru holes diagonal from each other.
7. Install the venturi plate assembly (item 122).
8. Attach the port manifold assembly (item 80) onto the venturi plate assembly (item 122), and valve body (item 7).
9. Install return pipe (item 75) into the tank return port of manifold (item 52).
10. Install screws (item 5) thru items 52, 116, 83, and into item 32. Torque to 22-25ft-lbs (30-34Nm).
11. Turn in "B" port relief valve (item 12) it bottoms out. Install plug (item 13) and torque to 10-12 ft-lbs (14-16 Nm).
12. Install new O-rings and backup washers on all three pistons (items 39, 38).
13. Install pistons (item 39) into the advance and retract bores in the cover (item 32). Grease the O-rings liberally and use insertion guide No. DC5122816 to help install the pistons. Install the springs (item 40) onto the pistons.
14. Lubricate O-ring on piston (item 38). Install spacer (item 36), spring (item 37), and piston (item 38) into pilot bore in cover (item 32) using insertion guide No. DC5122816. Insert seals (items 42, 41) into cover. Do not lubricate seals (items 42, 41).

15. Attach the cover (item 32) to the body (item 7) using the 6 screws (item 43), torque to 13-15 ft-lbs [18-20 Nm]. Install but do not tighten adjusting screw (item 35), copper washer (item 108), and jam nut (item 109). Do not install acorn nut (item 110) or second copper washer (item 108). Adjustments to the pilot pressure setting will be made later.
16. Install solenoid valve (item 104) using 4 screws (item 111) and lockwashers (item 113). Torque screws (item 111) to 5-6 ft-lbs [7-8 Nm].
17. Valve is now ready to be adjusted and tested.

ADJUSTMENTS:

1. Mount valve on pump. Insert a 5000 psi [344 bar] gauge to the port labeled "Pilot Pressure".
2. If installed, remove acorn nut (item 110) and copper washer (item 108). Screw in adjustment screw (item 35) until it bottoms out then unscrew two (2) complete turns.
3. If installed, remove pipe plug (item 13) at the pilot relief valve. Screw in the adjustment screw (item 12) until it bottoms out on sleeve or step, then unscrew one (1) complete revolution.
4. Using a push-button pendant or the manual override on the solenoid valve, energize the "A" side of the solenoid valve and slowly screw in the set screw (item 12) until a pressure of 2200 psi [151 bar] is reached. Install the pipe plug (item 13).
5. Adjust the pilot pressure setting to 1200-1400 psi [82-96 bar] using the adjustment screw (item 35). Tighten locknut (item 109) to lock the adjustment screw (item 35). Install copper washer (item 108) and acorn nut (item 110).
6. Connect the "A" port to the advance side of a single-acting cylinder and a 15,000 psi [1034 bar] gauge.
7. Remove 5000 psi (344 bar) pressure gauge and install pipe plug (item 34). Torque to 10-12 ft-lbs (14-16 Nm).
8. Advance to 10,000psi (690bar) and retract the single-acting cylinder. If the cylinder does not build pressure to 10,000 psi [690 bar] or retracts the single acting cylinder, repeat step 1-7 above.
9. Advance and retract the cylinder several times under no load, to eliminate air in the system.
10. The valve should hold pressure in the advance direction. At 10,000 psi [700 bar] there should be less than a 300 psi [21 bar] drop in pressure in 15 seconds. When the valve is in the "Hold" position there should be no cylinder creep.
11. Retract the cylinder. Ensure that no trapped pressure registers on the "A" port of the manifold (item 52).

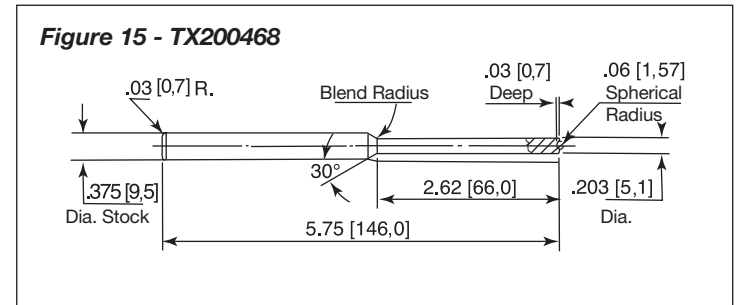
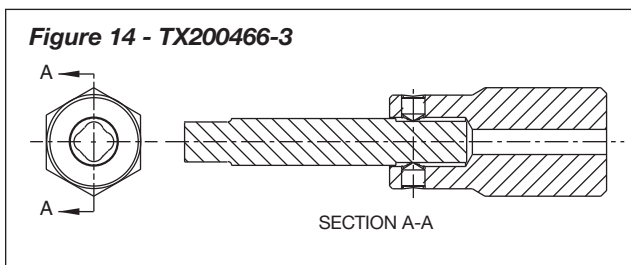
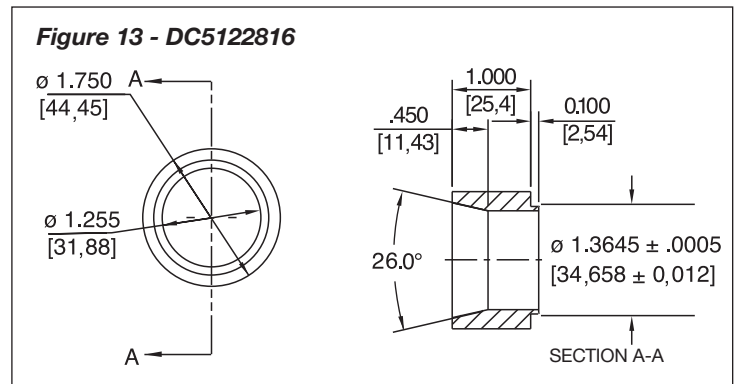
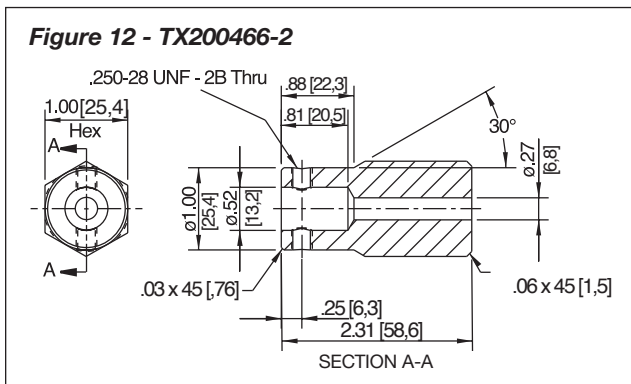
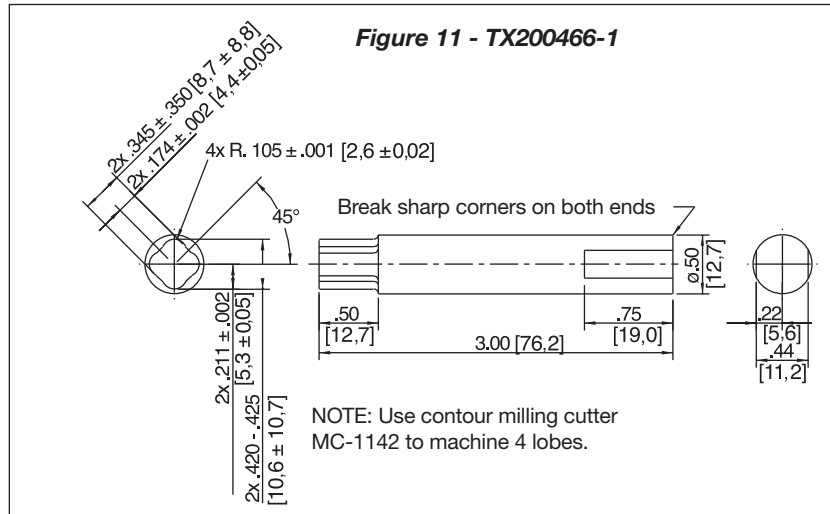

Special Tools							
Fig.	Part Number	Qty.	Description/Material	Fig.	Part Number	Qty.	Description/Material
11	● TX200466-1	4	Seat Tool	14	● DC5122816	1	Guide, Bushing
12	● TX200466-2	1	Tool Holder	15	● TX200468	1	Coining Tool
13	● F2540027B	1	SHSS, .250-28 x .25	N/S	● CK911032	1	Reducer, 1/4-1/8 NPT
13	● TX200466-3	1	Special Tool (complete)				

● Item included in special tool kit TXK400. N/S = Not Shown.

NOTE: TX200466-3 includes TX200466-1 (qty. 1), TX200466-2 (qty. 1) and F2540027B (qty. 2).

