

INDEX

1.0 SAFETY 1
 2.0 PRODUCT DATA 5
 3.0 CONFORMANCE TO NATIONAL AND INTERNATIONAL STANDARDS 8
 4.0 DESCRIPTION 8
 5.0 RECEIVING INSTRUCTIONS 8
 6.0 SET-UP 8
 7.0 CUTTING HEAD 10
 8.0 CUTTER OPERATION 11
 9.0 MAINTENANCE 14
 10.0 STORAGE 17
 11.0 TROUBLESHOOTING 18

1.0 SAFETY

1.1 Introduction

Read all instructions carefully. Follow all recommended safety precautions to avoid personal injury as well as damage to the product and/or damage to other property. Enerpac cannot be responsible for any damage or injury from unsafe use, lack of maintenance or incorrect operation. Do not remove warning labels, tags, or decals. In the event any questions or concerns arise, contact Enerpac or a local Enerpac distributor for clarification.

If you have never been trained on high-pressure hydraulic tool safety, consult your distributor or service center for information about an Enerpac hydraulic safety course.

This manual follows a system of safety alert symbols, signal words and safety messages to warn the user of specific hazards. Failure to comply with these warnings could result in death or serious personal injury, as well as damage to the equipment or other property.



The Safety Alert Symbol appears throughout this manual. It is used to alert you to potential physical injury hazards. Pay close attention to Safety Alert Symbols and obey all safety messages that follow this symbol to avoid the possibility of death or serious personal injury.

Safety Alert Symbols are used in conjunction with certain Signal Words that call attention to safety messages or property damage messages and designate a degree or level of hazard seriousness. The Signal Words used in this manual are DANGER, WARNING, CAUTION and NOTICE.

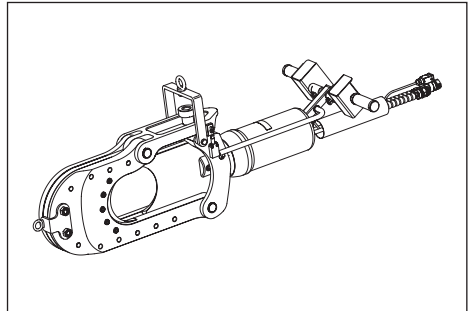

DANGER Indicates a hazardous situation that, if not avoided, will result in death or serious personal injury



WARNING Indicates a hazardous situation that, if not avoided, could result in death or serious personal injury.



CAUTION Indicates a hazardous situation that, if not avoided, could result in minor or moderate personal injury.



NOTICE Indicates information considered important, but not hazard related (e.g. messages relating to property damage). Please note that the Safety Alert symbol will not be used with this signal word.

1.2 Hydraulic Cutter Safety Precautions



WARNING Failure to observe and comply with the following precautions and instructions may result in death or serious personal injury. Property damage could also occur.

- Read and completely understand the safety precautions and instructions in this manual. Always follow all safety precautions and instructions, including those that are contained within the procedures of this manual.
- Read this manual before operating the cutter, or before performing any adjustments, inspections, maintenance or repairs.
- Follow all instructions and heed all precautions stated in this manual.
- Keep this manual for future reference in a place that is accessible to all persons operating or servicing the cutter.

- Always perform a visual inspection of the cutter before placing it into operation. If any problems are found, do not use the tool. Make repairs before using the cutter.
- Do not use the cutter if it is leaking oil. Do not use the cutter if damaged, altered or in need of repair.
- Do not remove or disable cutter safety devices. Before using the cutter, make sure that all the safety devices (guards, etc.) are in place and in good condition.
- Do not disable or bypass cutter safety switch.
- Do not remove the guards installed on the cutter or on any accessories. Replace any guards immediately if they develop faults or become damaged.
- Do not alter the calibration of the safety devices, such as maximum pressure valves (if equipped).
- Allow only authorized, trained, and experienced personnel to operate the cutter and supervise its use.
- Ensure that all users are trained and qualified to operate the cutter. Operators must be aware of all applicable occupational safety laws and must operate the cutter in accordance with all such laws.
- Keep the work area clean and well illuminated.
- When operating the cutter, do not wear loose clothing or jewelry. These items could get caught up in the cutter during operation. Tie up long hair.
- Always wear and use appropriate personal protective equipment (PPE) such as non-skid safety shoes, hard-hat, hearing protection, and face and eye protection. Use of these and other PPE items (used as appropriate for the conditions) will reduce the chance of personal injuries. The use of these items may also be required by local regulations or laws.
- Consult your employer concerning specific safety requirements and the safety equipment required for use in your country or region.
- Be certain that the cutting head is closed before starting the cutter.
- Always stop the cutter before opening the cutting head. Never open the cutting head during operation.
- Before reaching inside the cutting area for any reason, always stop the pump, relieve hydraulic pressure and disconnect pump from AC power supply.
- Keep others clear of the work area while the tool is in use. Be sure that all personnel not operating the cutter remain at a safe distance when the cutter is in operation.
- Stop the cutter if people and/or animals enter the work area.
- Ensure that the operator is alert, observant of the task being performed and that the work is being done with care.
- Do not allow use of the cutter by persons that are tired, or under the influence of drugs, alcohol or medication.
- Do not allow children to operate the cutter or to assist with its use. Keep children out of the work area.
- Place the tool horizontally on a substantial work surface. The work surface must have a rated weight capacity that exceeds the weight of the cutter and of the material being cut.
- Fragments and splinters may be ejected from the cutter during normal use. The end of the material being cut may become a projectile as it separates during cutting. Stay clear of the cutting head and surrounding area during operation. Always wear face and eye protection.
- As needed, remove any foreign objects from the cutting head that could damage the cutter and/or injure the operator. Before removing any foreign objects, always stop the pump, relieve hydraulic pressure and disconnect pump from AC power supply.
- Avoid touching the cutter's metal surfaces during operation and after the cutter has been in use. Be aware of the risk of burns if the cutter becomes hot.
- Do not use the cutter for activities other than those it was approved and designed to perform. Refer to Section 8.1 of this manual for additional information regarding foreseen use.
- Use the cutter lifting eyes and appropriately rated lifting equipment if it is necessary to lift or suspend the tool by mechanical means.
- Do not exceed equipment ratings. Be certain that the properties of the material to be cut do not exceed the stated maximum limits applicable to your cutter model. Refer to Section 2.1 of this manual. Overloading may cause equipment failure and possible personal injury.
- Do not use the cutter in explosive atmospheres (for example, in the presence of flammable liquids, gasses or powders).
- Do not use the cutter on live electric lines, on pressure vessels or ducts, or on vessels containing corrosive and/or toxic substances.
- If the cutter malfunctions, stop use immediately. Check for misaligned or jammed moving parts, broken components and any other condition that could make the tool operate incorrectly. Place the cutter back into operation only after the fault has been identified and the identified repairs and/or adjustments have been performed.
- Ensure that any repairs are performed only by trained, qualified and authorized staff using original equipment replacement parts. For repair service, contact the Enerpac authorized service center in your area.
- Use only original equipment Enerpac parts. Enerpac parts are designed to fit properly and to withstand high loads. Non-Enerpac parts may break or cause the product to malfunction.
- Keep cutting tools clean and replace blades when they become dull. Suitably maintained cutting tools with sharp edges are less likely to jam and are easier to control.

1.3 General Hydraulic Tool Safety Precautions (Tools with external hydraulic pumps)

⚠ WARNING Failure to observe and comply with the following precautions and instructions could result in death or serious personal injury. Property damage could also occur.

- Always read, follow and completely understand all manufacturer's instructions when operating pumps, valves and all other devices used with the tool. Follow all safety precautions contained in the manufacturer's manuals.
- Use the tool only with a compatible Enerpac pump. Use of a non-compatible pump may result in erratic and/or unsafe operation.
- The tool is designed for a maximum working pressure of 10,150 psi [700 bar]. Do not connect the tool to a pump with a higher pressure rating. Be certain that all hydraulic hoses and fittings are properly connected and that they are rated at 10,150 psi [700 bar] or higher.
- Never set a relief valve to a higher pressure than the maximum rated pressure of the pump and tool. If ratings are different, relief valve setting should not exceed the setting of the lowest rated component (pump or tool).
- Perform cleaning, maintenance and repair operations only after disconnecting the tool from the hydraulic pump.
- Wear suitable personal protective equipment (PPE) such as goggles, gloves and protective clothing when checking hoses and fittings.
- Do not leave the tool unattended in the workplace when it is connected to the hydraulic pump.
- The tool is designed for noncontinuous use. Allow sufficiently long pauses to allow the oil to cool. Consult Enerpac if prolonged and/or interrupted use is required.
- Do not expose tool to temperatures in excess of 158°F [70°C]. Allow tool to cool or remove heat source.
- Be aware of hot metal components. Avoid contact with these components to prevent burns.
- Do not handle pressurized hoses. Escaping oil under pressure can penetrate the skin. If oil is injected under the skin, see a doctor immediately.
- Do not pressurize disconnected couplers.
- Never use a hydraulic cylinder or tool with uncoupled couplers.
- Do not remove or disable the pump relief valve. Do not remove or disable the tool relief valve (if equipped).
- Monitor the system hydraulic pressure gauge (or digital pressure readout). It is your window to see what is happening in the system.

- Always be certain that hydraulic pressure is fully relieved before disconnecting hydraulic hoses, loosening hydraulic fittings, or performing any tool disassembly or repair procedures.

⚠ CAUTION Failure to observe and comply with the following precautions and instructions could result in minor or moderate personal injury. Property damage could also occur.

- To help ensure proper operation and best performance, use only Enerpac HF hydraulic oil. Use of any other oil may result in unsafe operation and /or damage to tool. The Enerpac product warranty may also be invalidated.
- Be careful to avoid damaging hydraulic hoses. Avoid sharp bends and kinks when routing hydraulic hoses. Do not exceed the minimum bend radius specified by the hose manufacturer. Using a bent or kinked hose will cause severe back-pressure. Sharp bends and kinks will internally damage the hose, leading to premature hose failure.
- Do not drop heavy objects on hoses. A sharp impact may cause internal damage to hose wire strands. Applying pressure to a damaged hose may cause it to rupture.
- Do not lift hydraulic equipment by the hoses or couplers. Use the equipment handle(s) or lifting eye(s) (if equipped) and appropriately rated lifting equipment.
- Keep hydraulic equipment away from flames and heat. Excessive heat will soften packings and seals, resulting in fluid leaks. Heat also weakens hose materials and packings.
- Protect all hydraulic equipment from weld spatter.

1.4 Safety Symbols (on cutter)

⚠ WARNING Failure to observe and comply with the safety symbols affixed to the cutter housing could result in death or serious personal injury.

⚠ WARNING Make sure the safety symbols (decals, labels, etc.) are securely affixed to the tool and that they are legible. If not, obtain replacements from Enerpac. Refer to tool repair parts sheet for locations and part numbers. Failure to maintain safety symbols on tool could result in death or serious personal injury.

The following safety symbols are affixed to the cutter housing:



Crush hazard: Keep hands, fingers and other body parts away from the cutting head during operation.



Projectile hazard: Objects may be ejected from the cutter during operation. Stay clear of cutting area. Wear eye and face protection.



PPE Alert: Wear personal protective equipment (PPE) when using or servicing equipment.



Instruction Manual Alert: Read the instruction manual before using or servicing equipment.

1.5 Disconnecting Pump AC Power

WARNING Pump **MUST** be disconnected from the AC power supply before performing cutter maintenance, repair or cleaning procedures, or before allowing persons to reach inside the cutting head for any reason. Failure to observe this precaution may result in serious personal injury.

- Cutter will operate immediately when pump motor is running, and either of the cutter push buttons is depressed.
- If it is not possible to unplug the pump power cord from the AC power outlet, turn off and lock out power at the AC power supply and disconnect the hydraulic hoses.
- Refer to the separate pump instruction sheet (provided with the pump) for detailed pump safety, operation and maintenance instructions.

1.6 Crush Hazard

DANGER Cutter will start immediately when pump motor is ON and cutter advance or retract button is depressed.

DO NOT place hands, fingers or other parts of your body inside the cutting head unless pump is disconnected from AC power supply. Death or serious personal injury will result if cutter is operated while persons are working inside the cutting head.

- Never reach into the cutting head while cutter is in operation.
- Before reaching inside the cutting head for any reason, always stop the pump, relieve hydraulic pressure, and disconnect pump from AC power supply.



CRUSH HAZARD

Do not reach inside cutting head unless pump is disconnected from AC power supply.

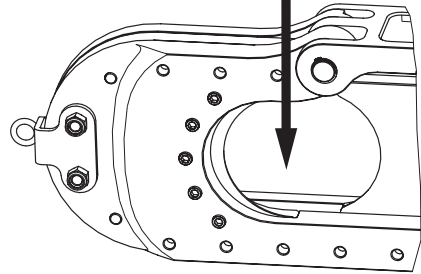

2.0 PRODUCT DATA

2.1 Cutter Maximum Capacities

Cutter Model No.	Material to be Cut	Material Maximum Tensile Strength		Material Maximum Hardness
		psi	daN/mm ²	Rockwell C
EWCH180	Round ropes or cables.	94,275	65	43

NOTICE Material to be cut must not exceed any of the stated maximum limits shown in this table.

These specifications are independent material limits provided to help prevent premature blade damage. They should not be considered as an indication of the maximum cutting capacity of the tool.

The tool will not necessarily cut the largest piece of material that will fit between the blades, even if the material properties are equal to or less than the stated maximum limits.

Cutting performance, including whether a cut can be completed, will depend on the material properties, blade condition, and the size and shape of the material being cut. If the tool is struggling or failing to make a cut, select a larger capacity tool.

2.2 Specifications

Cutter Model No.	Weight		Max. Hyd. Operating Pressure		Ambient Operating Temp		Hyd. Pump*
	lb	Kg	psi	bar	°F	°C	
EWCH180	330	149.5	10,150	700	-40 to +122	-40 to +50	External

Notes:

* Hydraulic pump sold separately. Special Enerpac pump required. Refer to Section 6.1 for additional information.

Product specifications are subject to change without notice.

2.3 External Dimensions

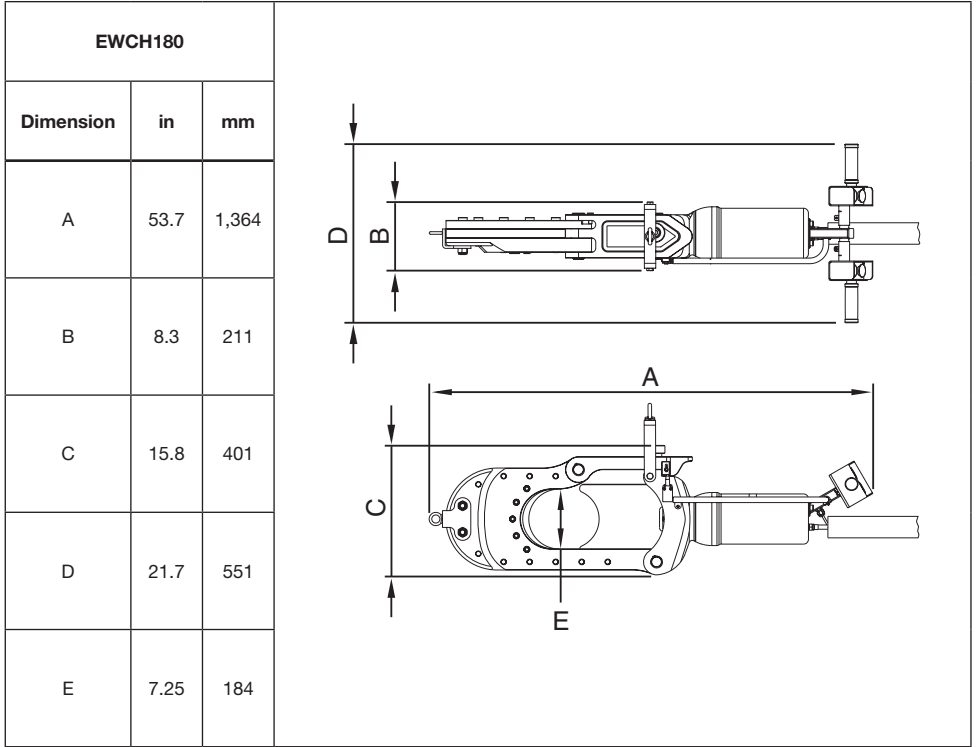

Product dimensions are subject to change without notice.

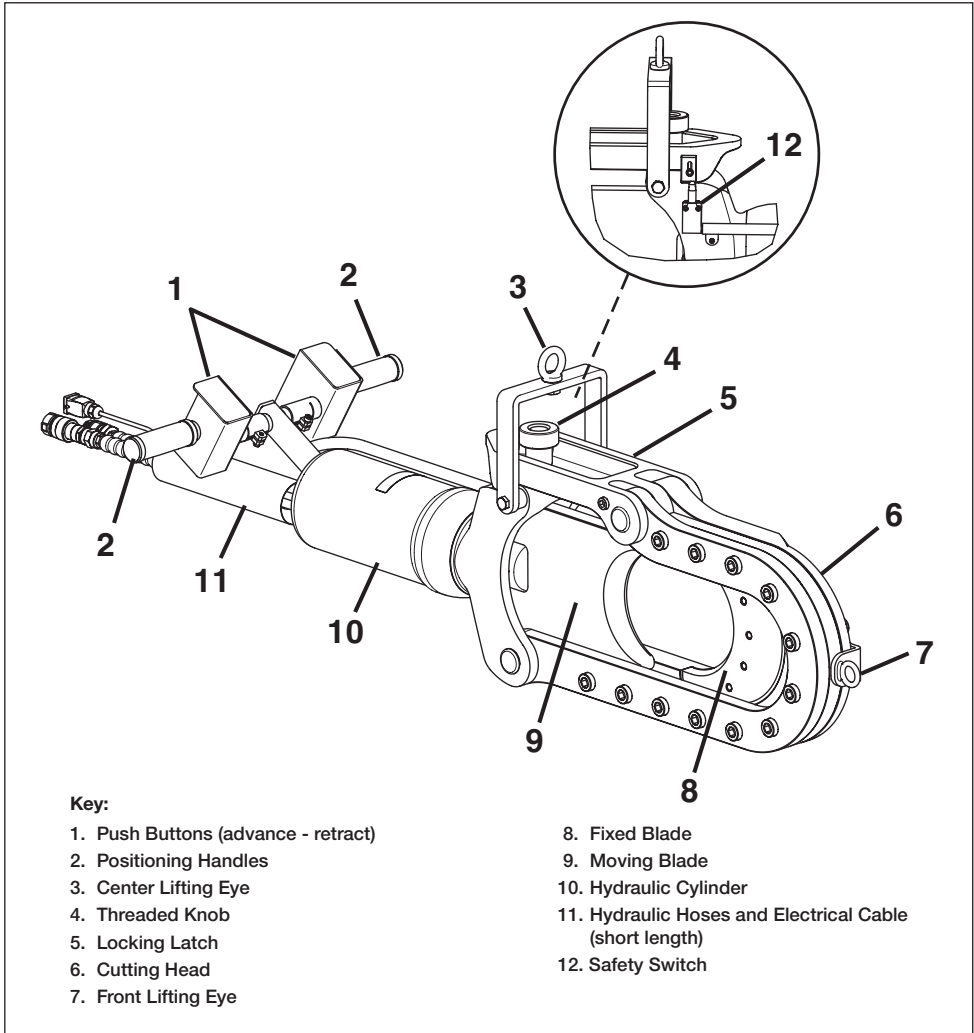

Figure 1, Features and Components

3.0 CONFORMANCE TO NATIONAL AND INTERNATIONAL STANDARDS



Enerpac declares that this product has been tested and conforms to applicable standards and is compatible with all CE requirements.

A copy of an EU Declaration of Conformity is enclosed with each shipment of this product.

4.0 DESCRIPTION

Enerpac model EWCH180 is a fixed-head hydraulic cutter designed to cut round ropes and cables.

The cutter contains two blades, one fixed and one moving. The moving blade is actuated by an integral double-acting hydraulic cylinder. The double-acting design ensures positive blade return and also helps prevent jamming or sticking.

Hydraulic power is supplied by an Enerpac hydraulic pump, which is sold separately from the cutter. Refer to Section 6.1 for additional pump information.

See Figure 1 for a description of cutter major features and typical items included in the shipment. Refer to Section 2.0 for cutter maximum capacities, specifications and dimensions.

5.0 RECEIVING INSTRUCTIONS

Visually inspect all components for shipping damage. Shipping damage is not covered by warranty. If shipping damage is found, notify carrier at once. The carrier is responsible for all repair and replacement costs resulting from damage in shipment.

6.0 SET-UP

6.1 Hydraulic Pump Requirements

The cutter must be used in conjunction with a specially designed hydraulic pump (sold separately). This pump contains unique valving and controls that are specific to the cutter.

Refer to the pump instruction sheet for detailed pump setup and operation instructions. Also refer to Section 6.4 of this manual for additional details.

6.2 Hydraulic Connections

A high pressure twin hydraulic hose assembly connects the pump control valve to the cutter. The hoses are included as part of a hose subassembly that also contains an electrical cable for the cutter controls. This subassembly is not included with the cutter and must be purchased separately.

To facilitate connections, quick-disconnect hydraulic couplers are present on the hoses, the cutter, and on the pump control valve.

⚠ WARNING Hydraulic oil can reach very high temperatures even when the cutter is idle and cutting force is not being applied. To prevent burns, always use suitable personal protective equipment when connecting or disconnecting couplers on a cutter that has been in operation.

⚠ WARNING Never use any hydraulic component that contains damaged hydraulic couplers. Never connect or disconnect a hydraulic coupler if the hydraulic circuit is pressurized. Failure to observe these instructions may result in the uncontrolled release of pressurized hydraulic oil. Skin penetration may occur. Death or serious personal injury could result.

NOTICE All hydraulic hoses and fittings used with the cutter must be rated at 10,150 psi [700 bar] or above.

6.2.1 Connecting the Hydraulic Couplers

1. Be sure that pump motor is stopped.
2. Be certain there is no residual pressure in the hydraulic circuit. If pressure is present, discharge the pressure in accordance with the instructions in the pump instruction sheet.

Repeat steps 3 through 6 for each hydraulic connection. See Figures 2 and 3 for hookup details.

NOTICE Before connecting hydraulic hoses, be certain that the electrical cable (included in hose and cable subassembly) is properly oriented. Note that electrical connectors are different on cutter and pump ends.

3. Remove the coupler dust caps.
4. Inspect the couplers after removing the dust caps. Remove any oil, dust or dirt.
5. Push the male and female couplers firmly together until engagement occurs.
6. Screw the threaded collar of the female coupler fully onto the threaded flange of the male coupler. Be sure that no threads are visible.

6.2.2 Disconnecting the Hydraulic Couplers

1. Be sure that pump motor is stopped.
2. Be certain there is no residual pressure in the hydraulic circuit. If pressure is present, discharge the pressure in accordance with the instructions in the pump instruction sheet.

Repeat steps 3 through 5 for each hydraulic connection. See Figures 2 and 3.

3. Unscrew the threaded collar of the female coupler from the threaded flange of the male coupler.
4. Disconnect the couplers. Remove any oil, dust or dirt.
5. Reinstall the coupler dust caps.

6.3 Electrical Connections

An electrical cable connects the pump electrical circuits to the push button controls mounted on the cutter. This cable is included as part of the hydraulic hose and electrical cable subassembly.

Connect the electrical cable as described in the following steps. See Figures 2 and 3.

1. Be sure that pump is disconnected from AC power supply.
2. Connect one end of the electrical cable to the electrical connector at the pump electrical control box.
3. Connect the other end of the electrical cable to the electrical connector at the cutter.

6.4 Pump Setup

Prepare the pump for operation as described in the pump instruction sheet.

Before connecting the pump to the cutter, verify that the pump relief valve is set at 10,150 psi [700 bar].

If the pump and/or cutter is being used for the first time, be certain to bleed air from the hydraulic system as described in Section 8.4 before using the cutter.

Verify that pump oil level is correct and that there are no oil leaks or other obvious problems.

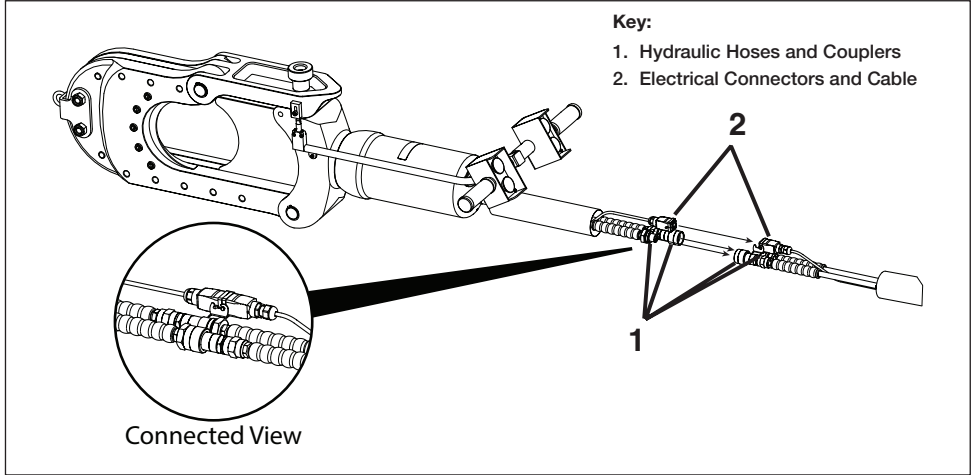

Figure 2, Hydraulic and Electrical Connections at Cutter

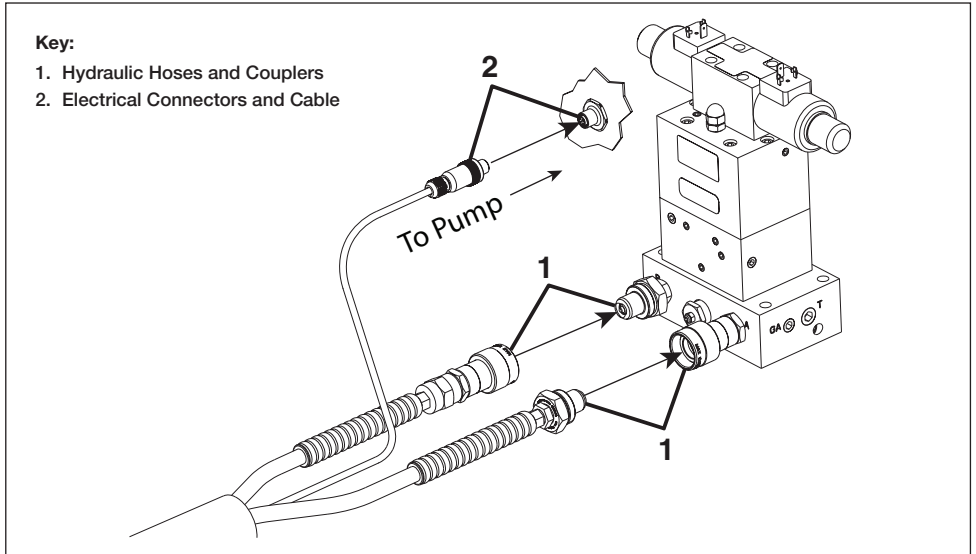

Figure 3, Hydraulic and Electrical Connections at Pump

7.0 CUTTING HEAD

7.1 Description

When closed, the cutting head helps prevent hand contact with the moving piston and blade.

⚠ WARNING Failure to observe and comply with the following precautions and instructions could result in serious personal injury.

- Always close the cutting head before beginning the cutting process.
- Never attempt to operate cutter with cutting head open.
- Never open cutting head while cutter is operating. Cutting head must remain closed until cutter is stopped.
- Before reaching inside the cutting head to clear jams or for any other reason, always stop the pump, relieve hydraulic pressure and disconnect pump from AC power supply.
- Always close cutting head after performing any adjustments, maintenance or repairs.
- Be certain that cutting head is in good condition and secured.

7.2 Opening and Closing the Cutting Head

The cutting head can be opened and closed to allow the material to be inserted into the cutting head.

⚠ WARNING Be certain that cutter is off before opening or closing the cutting head. Serious personal injury may result if this precaution is not observed.

To open the cutting head: unscrew the threaded knob (Figure 4, item 1). Lift the locking latch (Figure 4, item 2) and swing it up and away from the cutter body. Then, swing the cutting head away from the cutter body as shown in Figure 4.

To close the cutting head: swing the cutting head toward the cutter body. Then, push down on the locking latch (Figure 5, item 2) and install the threaded knob (Figure 5, item 1) to lock the cutting head in place, as shown in Figure 5.

NOTICE A safety switch is located at the rear of the cutting head. Locking latch must be engaged and threaded knob must be fully installed to allow cutter to operate.

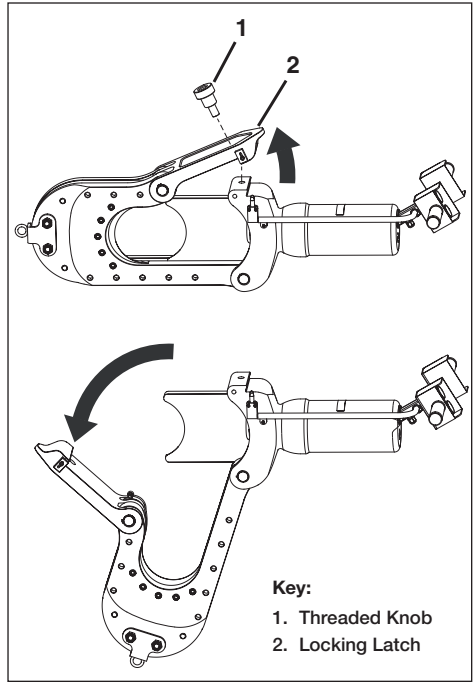

Figure 4, Opening the Cutting Head

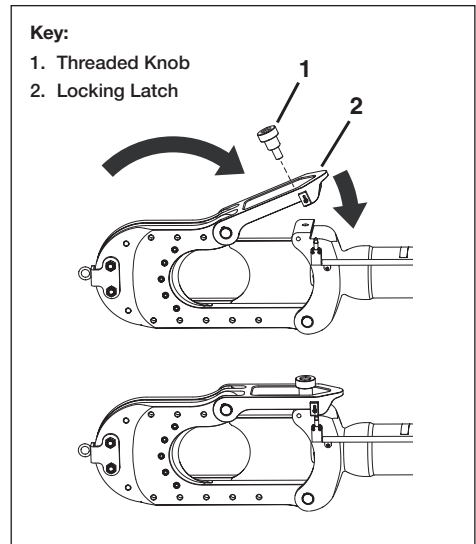

Figure 5, Closing the Cutting Head

8.0 CUTTER OPERATION

8.1 Foreseen Use and Residual Risks

⚠ WARNING Failure to observe and comply with the instructions and precautions contained in the following paragraphs could result in death or serious personal injury.

1. The cutter is designed for cutting round ropes and cables. Be certain that the properties of the material to be cut do not exceed the stated maximum limits applicable to your cutter model. Refer to Section 2.1.
2. The cutter may be used only when connected to a compatible Enerpac hydraulic pump.
3. Operators must observe the instructions in this manual in order to minimize the risk of accidents. In particular, operators must pay attention when working in conditions that could cause:
 - Possible burns from overheated parts.
 - Injury due to incorrect positioning or inadequate lifting or moving.
 - Injury caused by splinters discharged from the cable or other work piece.

⚠ WARNING People remaining in the vicinity of the cutter while it is working are subject to the risk of flying debris (dangerous objects, etc.). Serious personal injury could result.

4. Incorrect Uses:

- Cutter must not be used for purposes other than those indicated in this document.
- Cutter must not be used in areas subject to the risk of explosion.

8.2 Positioning and Transporting the Cutter

- Before inserting material to be cut inside the cutting head, be certain that the cutter is positioned on a solid and stable work surface of sufficient weight rating capacity. Refer to Section 2.2 for cutter weight.
- Position the cutter as needed using the cutter positioning handles and appropriately rated lifting equipment (if needed). See Figure 1.
- If it is necessary to move or transport the cutter, use only the supplied lifting eyebolts. See Figure 6. Use appropriately rated lifting equipment.

⚠ WARNING Because the cutter components are very heavy, there is a risk of cuts, crushing or broken bones. To avoid accidents, use care when working with the cutter. Serious personal injury may result if the cutter is not properly supported and handled in an appropriate way.

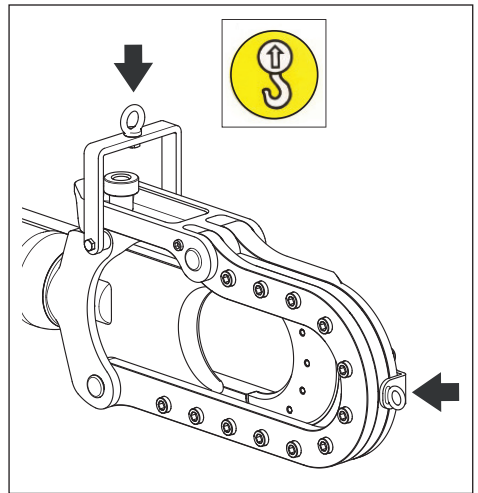

Figure 6, Cutter Lifting Location

8.3 Operating Precautions

⚠ WARNING Failure to observe the following precautions and instructions could result in death or serious personal injury.

- Keep fingers, hands and other body parts clear of the cutting head. Be certain that cutting head is closed and latched before starting the cutter.
- Do not attempt to reposition the item being cut while the cutter is in operation. Always stop the cutter and then move the piston to the “home” (fully retracted) position before repositioning the item.
- Dangerous projectiles could occur at any time during cutting. Always wear face and eye protection. Keep persons away from cutting area.
- Cutter surfaces can become very hot. To prevent burns, avoid contact with cutter components and wear appropriate personal protective equipment.
- Refer to additional safety precautions in Section 1.0 of this manual before using the cutter or performing any maintenance or repair activities.

8.4 Trapped Air Removal

Before placing a new cutter into operation, cycle the piston several times without load to remove any trapped air in the hydraulic circuit. The tool should also be placed below the pump so the air can escape to the pump reservoir.

Air is completely purged when the piston advances and retracts smoothly in both directions, from fully extended to fully retracted.

This procedure may also be performed after the cutter has been serviced.

Refer to the cutter controls information in Section 8.6 of this manual when performing the air removal procedure.

8.5 Positioning Material

Always be sure that the piston and moving blade are in the fully retracted "home" position before placing any material inside the cutting head. See Figure 7.

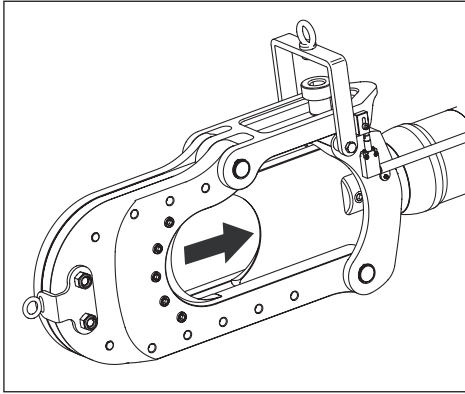

Figure 7, Piston and Blade in Home Position (fully retracted)

Open the cutting head and place the material inside. Then, close the cutting head. Refer to Section 7.2 for additional information.

Position the material to be cut between the cutter blades, so that it is perpendicular to the piston axis, as shown in Figure 8. This will provide the best quality cut while placing the least amount of load on the cutter.

NOTICE Be certain that the properties of the material to be cut do not exceed the stated maximum limits applicable to your cutter model. Refer to Section 2.1 of this manual for additional information. Failure to observe the instruction may result in poor cutting performance and/or damage to the cutter.

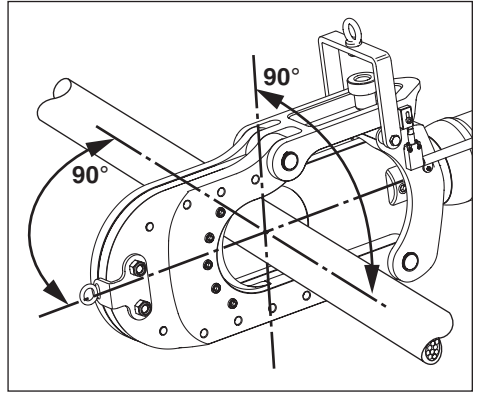

Figure 8, Positioning Material in the Cutting Head

8.6 Cutter Controls

Four push buttons control cutter operation. The two top push buttons activate the advance function. The bottom two push buttons activate the retract function.

With the pump motor ON:

- Press and hold both **advance** push buttons to advance the piston and slide the moving blade forward. See Figure 9.
- Press and hold both **retract** push buttons to retract the piston and slide the moving blade backward. See Figure 10.
- Release any push button at any time to stop movement of the piston and moving blade. Be advised that there may be a brief delay for the piston and blade to make a complete stop.

NOTICE A safety switch prevents the cutter from operating unless the locking latch is latched and the threaded knob is fully installed. Refer to Section 7.2 for additional information.

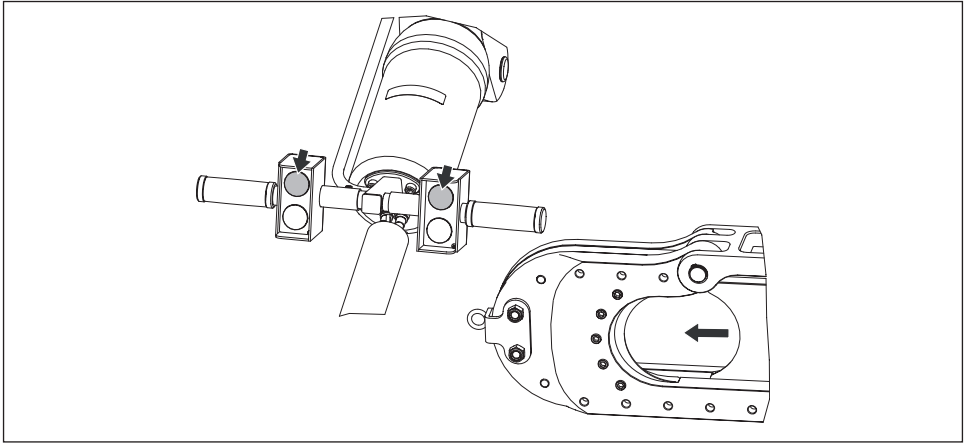

Figure 9, Operation - Advance/Cut

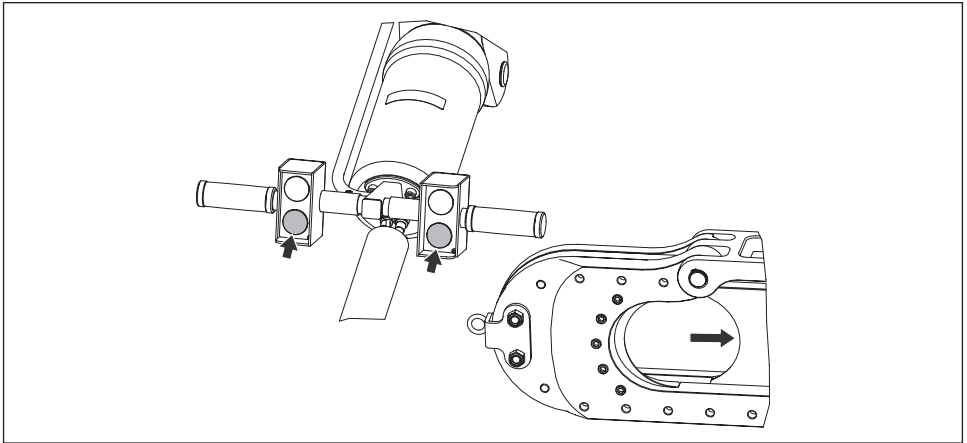

Figure 10, Operation - Retract

8.7 Cutting Procedure (typical)

1. Be certain that the properties of the material to be cut do not exceed the stated maximum limits applicable to your cutter model. Refer to Section 2.1.
 2. Be sure that the piston is in the “home” (fully retracted) position. See Figure 7.
 3. Open the cutting head. Refer to Section 7.2 for additional information.
 4. Place the material into the cutting head and close the cutting head. Refer to Section 7.2 for additional information.
 5. Place the material to be cut between the fixed and moving blades. Be sure that it is perpendicular to the piston axis, as shown in Figure 8. Refer to instructions in Section 8.5 for additional information.
- NOTICE** Failure to properly position the material in the cutting head may result in blade breakage and reduced cutting efficiency.
6. Start the pump motor.
 7. Press and hold down the advance push buttons until the item has been fully cut.
 8. Press and hold down the retract push buttons until the moving blade moves fully rearward and is in the “home” (fully retracted) position.

9.0 MAINTENANCE

9.1 Periodic Maintenance Table

Refer to the Periodic Maintenance Chart (Table 1) for a list of various routine checks and procedures.

⚠ WARNING Disconnect pump from AC power supply before performing any cleaning, maintenance or repair procedures. Failure to observe this precaution could result in death or serious personal injury.

9.2 Cleaning

- Clean the cutter using a dry cloth or compressed air. For plastic surfaces, use a cloth slightly dampened with water.
- Use a soft brush or compressed air to remove any cutting remnants or debris that have collected in the cutting head. These items can become caught between the blade and head, resulting in decreased blade/tool life. This should be checked often.

⚠ CAUTION To prevent possible injury, always wear safety glasses or face mask when using compressed air.

- Be sure there are no traces of oil, grease or corrosive substances on the tool, especially on the grips.
- Use a damp cloth and soapy water to clean plastic components.
- Do not use gasoline or thinner to clean the tool.

9.3 Fasteners

Periodically check all screws, nuts and other fasteners for proper tightness. Tighten any loose fasteners. Replace any worn or damaged fasteners. This should be performed periodically or every day in the event of frequent or prolonged cutter operation.

NOTICE Failure to check and tighten fasteners as required may result in serious damage to the cutter.

9.4 Preparation for Maintenance

All cutter maintenance procedures must be performed under the following conditions:

- All hydraulic pressure must be relieved. Refer to the pump instruction sheet for pressure relief procedure.
- The pump must be disconnected from the AC power supply.
- The cutter must be given time to cool to prevent burns.
- Procedures must be performed in a suitable work environment in accordance with all current safety regulations and/or laws in your country or region.
- The cutter must be cleaned thoroughly before maintenance procedures are performed.
- Suitable personal protective equipment (PPE) must be used and/or worn while performing any work.

⚠ WARNING Ensure that any guards or shields (if present) have been correctly reinstalled before placing the cutter back into service after maintenance procedures are completed. Failure to reinstall these devices could result in serious personal injury.

Table 1 - Periodic Maintenance Chart

Time Interval	Maintenance Operation	Method	To be performed by:
Frequently during use:	Check for any cutting remnants or debris that have collected in the cutting head. If these items are found, disconnect the pump from the AC power supply and remove remnants or debris as required.	Visual (refer to instructions in Section 9.2)	Operator
Every 8 hours of operation:	Check the cutter for loose, damaged or worn parts. Check for oil leaks. Tighten, replace or repair as required.	Visual	Operator
	Clean the cutter.	(Refer to instructions in Section 9.2)	Operator
	Check that screws and bolts are properly tightened. Replace any missing screws or bolts.	(Refer to instructions in Section 9.3)	Operator
As required:	Replace fixed blade.	(Refer to instructions in Section 9.5.1)	Operator
	Replace moving blade.	(Refer to instructions in Section 9.5.2)	Operator

9.5 Blade Replacement

The use of worn blades decreases the effectiveness of the cutter and can also side load the cylinder, possibly damaging the tool. Pump overheating may also occur.

Replace blades immediately when it is noticed that they are worn and/or damaged, or if there has been a noticeable decrease in cutting performance.

The cutter contains a fixed blade and a moving blade. Refer to Section 9.5.1 for fixed blade replacement instructions and to Section 9.5.2 for moving blade replacement procedures.

⚠ CAUTION Use extreme caution when removing and installing blades. Blades may be sharp even when worn. To avoid hand injury, wear appropriate hand protection and avoid contact with blade cutting edges.

NOTICE To help ensure even blade wear and optimum cutting performance, it is recommended that both the fixed blade and the moving blade be replaced at the same time.

9.5.1 Fixed Blade Replacement

Replace the fixed blade as described in the following steps. Refer to Figure 11.

1. Start the pump. Move the piston to the "home" position (fully retracted). See Figure 7.
2. Stop the pump. Be sure that hydraulic pressure is completely relieved.
3. Disconnect pump from AC power supply.

⚠ WARNING Always disconnect pump from AC power supply before beginning cutter blade replacement procedures. Failure to observe this precaution could result in accidental startup as procedures are being performed. Serious personal injury could result.

4. Place the cutter horizontally on a stable work surface.
5. Open the cutting head. Refer to Section 7.2 for additional information.

6. Remove retaining ring (Figure 11, item 4). Remove clevis pin (Figure 11, item 2) and cutting head (Figure 11, items 5-14).
7. Remove two socket head screws (Figure 11, item 13), lock nuts (Figure 11, item 6) and front lifting eye (Figure 11, item 7).
8. Remove two socket head screws (Figure 11, item 12) and eight socket head screws (Figure 11, item 14).
9. Separate left side outer plate (Figure 11, item 8), inner plate (Figure 11, item 10) and right side outer plate (Figure 11, item 11).
10. Remove five fixed blade screws (Figure 11, item 5) and remove fixed blade (Figure 11, item 9).
11. Install new fixed blade (Figure 11, item 9) onto left side outer plate (Figure 11, item 8) with five fixed blade screws (Figure 11, item 5) and torque to 64 ft-lb [87 Nm]. Also apply Loctite 243 or equivalent.
12. Assemble the left side outer plate (Figure 11, item 8), inner plate (Figure 11, item 10) and right side outer plate (Figure 11, item 11) using eight socket head screws (Figure 11, item 14) and two socket head screws (Figure 11, item 12). Torque to 213 ft-lb [289 Nm].
13. Install two socket head screws (Figure 11, item 13), front lifting eye (Figure 11, item 7) and lock nuts (Figure 11, item 6) and torque to 213 ft-lb [289 Nm].
14. Attach cutting head (Figure 11, items 5-14) to tool body using clevis pin (Figure 11, item 2) and retaining ring (Figure 11, item 4).
15. Close the cutting head. Refer to Section 7.2 for additional information.
16. Test for proper operation before placing the cutter back into service.

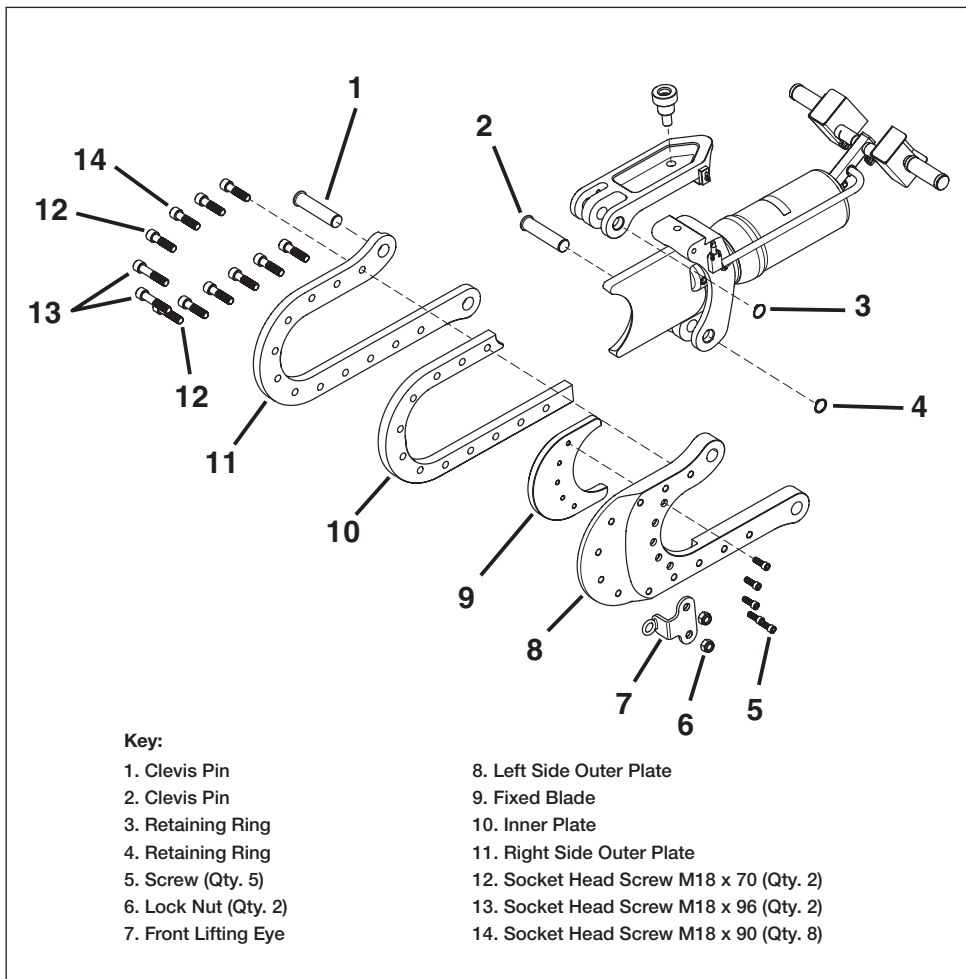

Figure 11, Fixed Blade Replacement

9.5.2 Moving Blade Replacement

Replace the moving blade as described in the following steps:

1. Start the pump. Retract the piston to the home position.
2. Stop the pump. Be sure that hydraulic pressure is completely relieved.
3. Disconnect pump from AC power supply.

⚠ WARNING Always disconnect pump from AC power supply before beginning cutter blade replacement procedures. Failure to observe this precaution could result in accidental startup as procedures are being performed. Serious personal injury could result.

4. Open the cutting head. Refer to Section 7.2 for additional information.
5. Loosen and remove the moving blade screw (Figure 12, item 1).

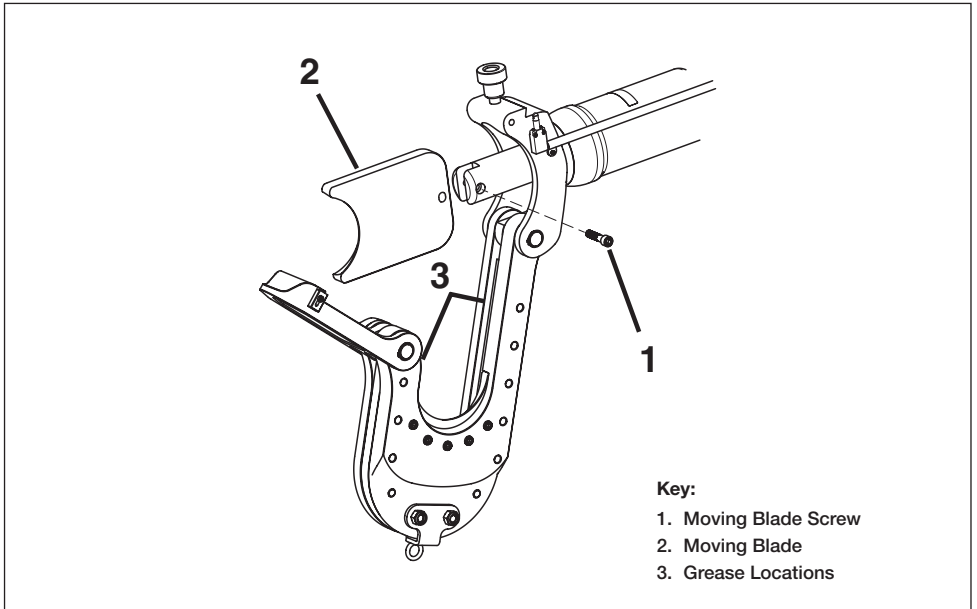

Figure 12, Moving Blade Replacement

6. Remove the worn moving blade (Figure 12, item 2).
7. Install new moving blade (Figure 12, item 2) into the piston.
8. Install the new moving blade screw (Figure 12, item 1). Torque to 102 ft-lb [138 Nm]. Apply Loctite 243 or equivalent.
9. Lubricate the slide slot and tool guide in the cutting head using an NLGI Grade 2 extreme pressure lithium grease (Figure 12, item 3).
10. Close the cutting head. Refer to Section 7.2 for additional information.
11. Test for proper operation before placing the cutter back into service.

10.0 STORAGE

10.1 Storage Guidelines

If the cutter will be stored for an extended period of time:

- Disconnect hydraulic hoses from cutter. Be sure that dust caps are installed on hydraulic couplers.
- Thoroughly clean the cutter.
- To help prevent corrosion, lubricate the cutter metal surfaces with a thin layer of oil.
- Store the cutter in a clean and dry place, accessible only to authorized personnel.

10.2 Return to Use (after storage)

Before using the cutter after an extended period of storage or inactivity, perform the following steps:

- Remove protective oil coating (applied before storage) from cutter surfaces.
- Check for oil leaks. Make repairs as required.
- Check that the tool hydraulic hoses and electrical cable are intact and undamaged.
- Check for any missing, worn or improperly installed parts.
- Check that all screws, nuts, bolts and other fasteners are tight.
- Replace, repair or tighten components as needed.
- Check for proper operation of cutter safety switch. Cutter must not run unless cutting head is closed, locking latch is latched and threaded knob is fully installed.

11.0 TROUBLESHOOTING

Refer to the Cutter Troubleshooting Chart (Table 2) for a list of common hydraulic cutter symptoms, possible causes and solutions.

For repair service, contact an Enerpac authorized service center. Inspection and repairs should be performed only by an Enerpac authorized service center or other qualified hydraulic tool service facility.

Table 2 - Cutter Troubleshooting Chart

Symptom	Possible Cause	Solution	Maint. Level
1. Piston moves slowly and/or has difficulty cutting the material.	Excessive cutting debris in the cutting head.	Clean out debris.	Operator
	Blocked or restricted hydraulic oil flow.	Check for incomplete hydraulic connections, blocked hydraulic hoses or other similar problems.	Operator
	Low hydraulic oil level.	Check oil level. Add oil if low.	Operator
	Material being cut is outside of acceptable specifications.	Material properties must not exceed stated maximum limits. Refer to Section 2.1.	Operator
	Low hydraulic oil pressure or flow.	Check pump relief valve setting. Troubleshoot and repair pump and solenoid control valve (as required).	Service Center
	Cutter seal wear and/or internal damage.	Repair cutter as required.	Service Center
2. Cutter vibrates during operation.	Loose or missing screws or bolts.	Verify screws and bolts are properly tightened. Replace any missing screws or bolts.	Operator
3. Piston does not advance or retract when pump motor is ON and cutter push buttons are pressed.	Pump not connected to electrical power.	Check that pump is connected to AC power supply. Be sure that pump is on.	Operator
	Electrical cable disconnected at pump or at cutter.	Connect electrical cable.	Operator
	Cutter safety switch open.	Close the cutting head. Engage locking latch and fully install threaded knob.	Operator
	Cutter push button switches and/or wiring defective.	Repair or replace cutter electrical components as required.	Service Center
	Pump solenoid control valve components defective.	Repair or replace control valve components as required.	Service Center
4. External oil leaks.	Loose hydraulic fittings.	Tighten loose fittings.	Operator
	Damaged hydraulic hoses.	Replace hoses.	Operator
	Damaged hydraulic couplers.	Replace couplers.	Service Center
	Worn or damaged cutter components.	Repair cutter as required.	Service Center

ENERPAC 

WWW.ENERPAC.COM