

Document Number	Document Revision	Document Revision Date	Product Date Code Beginning With
L4323	D	07/2019	A

To Protect Your Warranty, Use Only ENERPAC Hydraulic Oil.

Enerpac recommends that all kit components be installed to insure optimum performance of the repaired product.

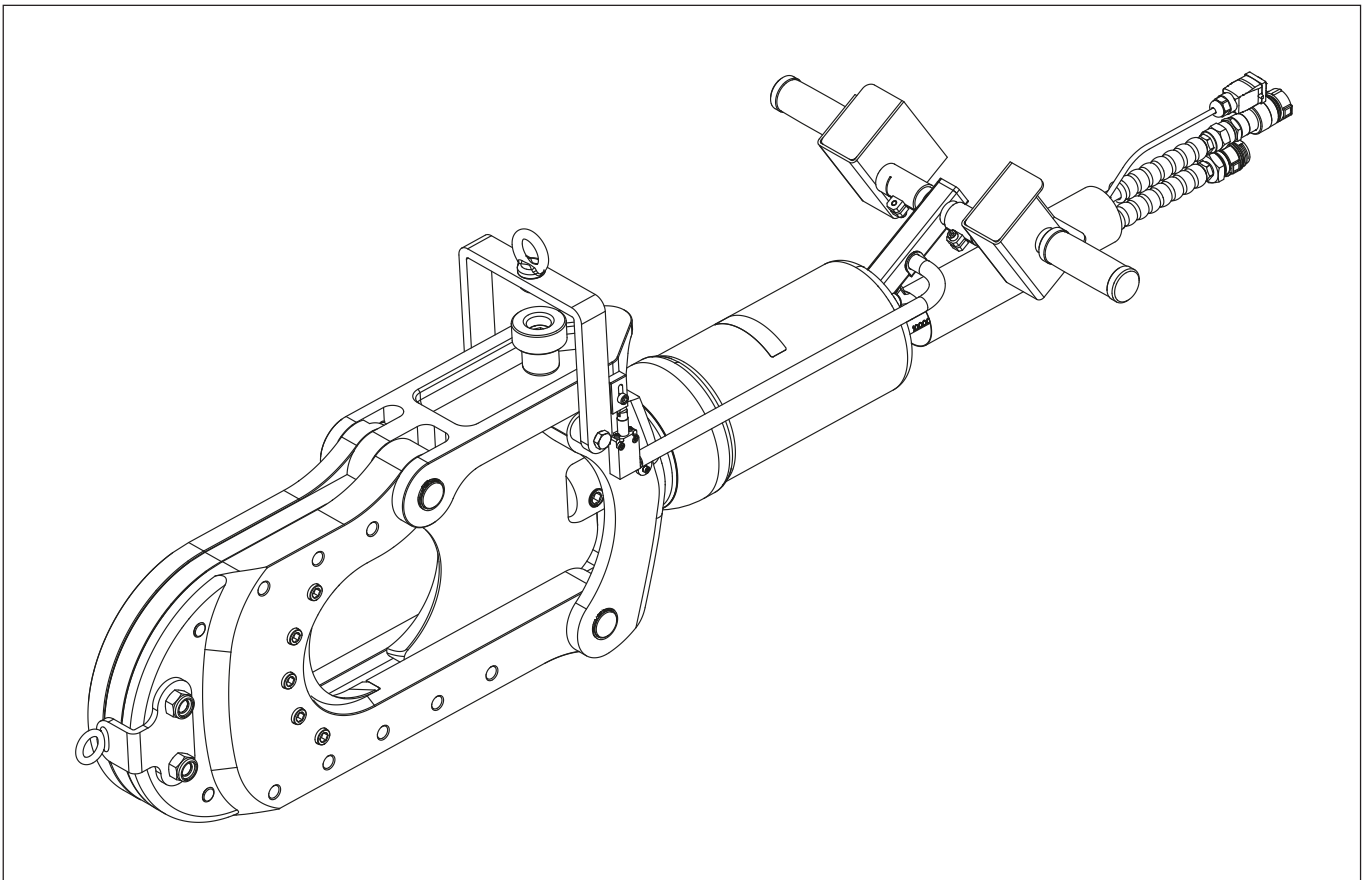

Table of Contents:

	Page		Page
Figure 1 - EWCH180 Cutter, Exploded View	2	Figure 10 - EWCH18009K Pin Kit	6
Figure 2 - EWCH18001K Blade Kit	4	Figure 11 - EWCH18010K Safety Switch Kit	7
Figure 3 - EWCH18002K Seal Kit	4	Figure 12 - EWCH18011K Handle Kit	7
Figure 4 - EWCH18003K Guide Kit	5	Figure 13 - EWCH18012K Latch Kit	8
Figure 5 - EWCH18004K Lift Kit	5	Figure 14 - EBH5206K Grip Kit	8
Figure 6 - EWCH18005K Switches Kit	5	Figure 15 - CKECHYD Connector Kit	8
Figure 7 - EWCH18006K Small Parts Kit	6	Figure 16 - ECH500IK Hydraulic Hose Kit	9
Figure 8 - EWCH18007K Head and Cylinder Body Kit	6	Figure 17 - CH720EC Hose and Cable Assembly Kit	9
Figure 9 - EWCH18008K Piston Kit	6	Figure 18 - DKSCOMP Decal Kit	10

⚠ WARNING Be certain that hydraulic pressure is completely relieved (0 psi/bar) before beginning any adjustment, maintenance or repair procedures. Appropriate shop safety procedures are to be followed during disassembly and reassembly to minimize any possibility of injury.

Note: Parts kits, components and product features described in this document are subject to change without notice.

Figure 1 - EWCH180 Cutter, Exploded View

Notes:

- 1 Torque to 3 Nm [26 in-lbs].
- 2 Torque to 10 Nm [91 in-lbs].
- 3 Torque to 50 Nm [37 ft-lbs].
- 4 Torque to 87 Nm [64 ft-lbs].
- 5 Torque to 138 Nm [102 ft-lbs].
- 6 Torque to 289 Nm [213 ft-lbs].
- 7 Apply Loctite 243.
- 8 Apply Loctite 542.
- 9 Hose with female quick coupler must be attached to the advance port of the tool.

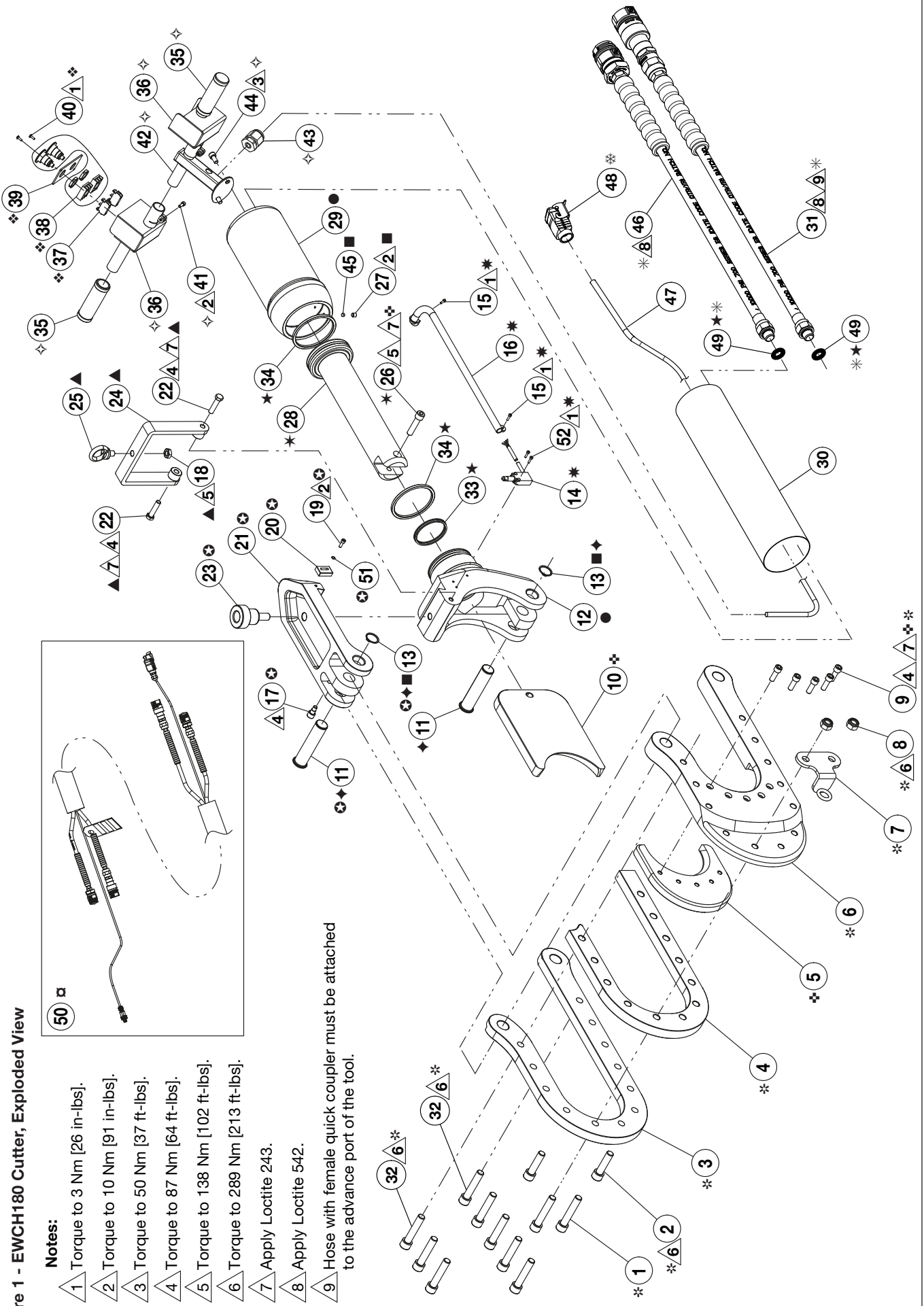
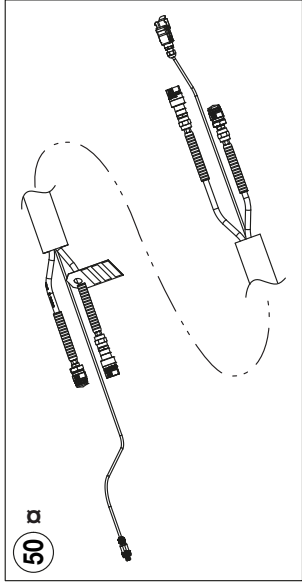

Repair Parts List for Figure 1			
Item No.	Part Number	Qty.	Description
1	*	2	Socket Cap Screw M18 x 96 UNI 5931 Zn
2	*	2	Socket Cap Screw M18 x 68 UNI 5931 Zn
3	*	1	Support Plate
4	*	1	Spacer Plate
5	◆	1	Fixed Blade
6	*	1	Fixed Blade Support
7	*	1	Lifting Hook
8	*	2	Lock Nut M18 Zn UNI 7474
9	◆*	5	Socket Cap Screw M12 x 35 UNI 5931 Zn
10	◆	1	Moving Blade
11	◆	2	Pin
12	●	1	Blades Support
13	■	2	Snap Ring External D=32 UNI 7435
14	*	1	Safety Switch
15	*	2	Socket Cap Screw M4 x 16 UNI 5931 Zn
16	*	1	Pipe
17	⊕	1	Limit Switch Screw M12
18	▲	1	Nut M14 UNI 5589
19	⊕	1	Socket Cap Screw M6 x 20 UNI 5931 Zn
20	⊕	1	Switch Flag
21	⊕	1	Hook
22	▲	2	HXBT screw M12 x 50 UNI 5739 Zn
23	⊕	1	Knob
24	▲	1	Lifting Hook
25	▲	1	Eyebolt M14
26	◆*	1	Socket Cap Screw M14 x 65 UNI 5931 Zn
27	■	1	Set Screw M10 x 16 12.9 UNI 5923
28	*	1	Piston
29	●	1	Cylinder Assembly
30	N/A	1	Protective Sheath
31	*	1	High Press. Hose (700 Series) G 1/4 F + CJ649096
32	*	8	Socket Cap Screw M18 x 90 UNI 5931 Zn
33	★	1	Gasket CSC 9080 90 x 80 x 8
34	★	2	Gasket NPU 0120 120 x 104.5 x 6.3
35	◇	2	Grip
36	◇	2	Handle Assembly
37	◆	4	Contact Block

Repair Parts List for Figure 1 (Continued)			
Item No.	Part Number	Qty.	Description
38	◆	4	Button CEMA P9NPN
39	◆	2	Button Panel
40	◆	4	Screw Self Threading M4 x 12 UNI 7985 Zn
41	◆	2	Socket Cap Screw M6 x 16 UNI 5931 Zn
42	◆	1	Handle Assembly
43	◆	1	Cable Gland
44	◆	2	Socket Cap Screw M10 x 20 UNI 5931 Zn
45	■	1	Plastic Pin D8 x 4.5
46	*	1	High Press. Hose (700 Series) G 1/4 F + DC1392900
47	N/A	1	Cable
48	*	1	Connector
49	★*	2	Bonded Seal Washer (included with items 36 and 37)
50	□	1	Hose and Cable Assembly, 6m long
51	⊕	1	Flat Washer 6.4 x 12 x 1.6 ISO 7089 Zn
52	*	2	Socket Cap Screw M4 x 20 UNI 5931 Zn

Kit Information			
Symbol	Included In	See Figure	
◆	EWCH18001K Blade Kit		2
★	EWCH18002K Seal Kit		3
*	EWCH18003K Guide Kit		4
▲	EWCH18004K Lift Kit		5
◆	EWCH18005K Switches Kit		6
■	EWCH18006K Small Parts Kit		7
●	EWCH18007K Head and Cylinder Body Kit		8
*	EWCH18008K Piston Kit		9
◆	EWCH18009K Pin Kit		10
*	EWCH18010K Safety Switch Kit		11
◇	EWCH18011K Handle Kit		12
⊕	EWCH18012K Latch Kit		13
◆	EBH5206K Grip Kit		14
*	CKECHYD Connector Kit		15
*	ECH500IK Hydraulic Hose Kit		16
□	CH720EC Hose and Cable Assembly Kit		17
N/A	DKSCOMP Decal Kit		18

Refer to figures 2 through 18 for kit part exploded views and additional service information.

N/A - Not Available

Figure 2 - EWCH18001K Blade Kit

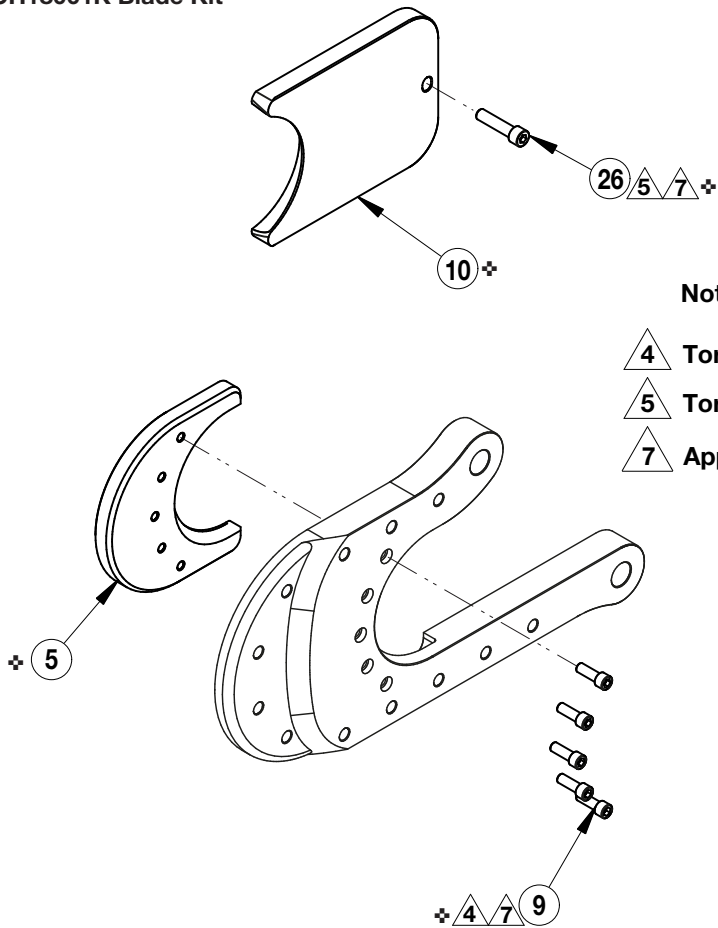

Notes:

- ▲ 4 Torque to 87 Nm [64 ft-lbs].
- ▲ 5 Torque to 138 Nm [102 ft-lbs].
- ▲ 7 Apply Loctite 243.

Refer to parts list in Figure 1 for part descriptions and quantities. (items marked "❖")

Figure 3 - EWCH18002K Seal Kit

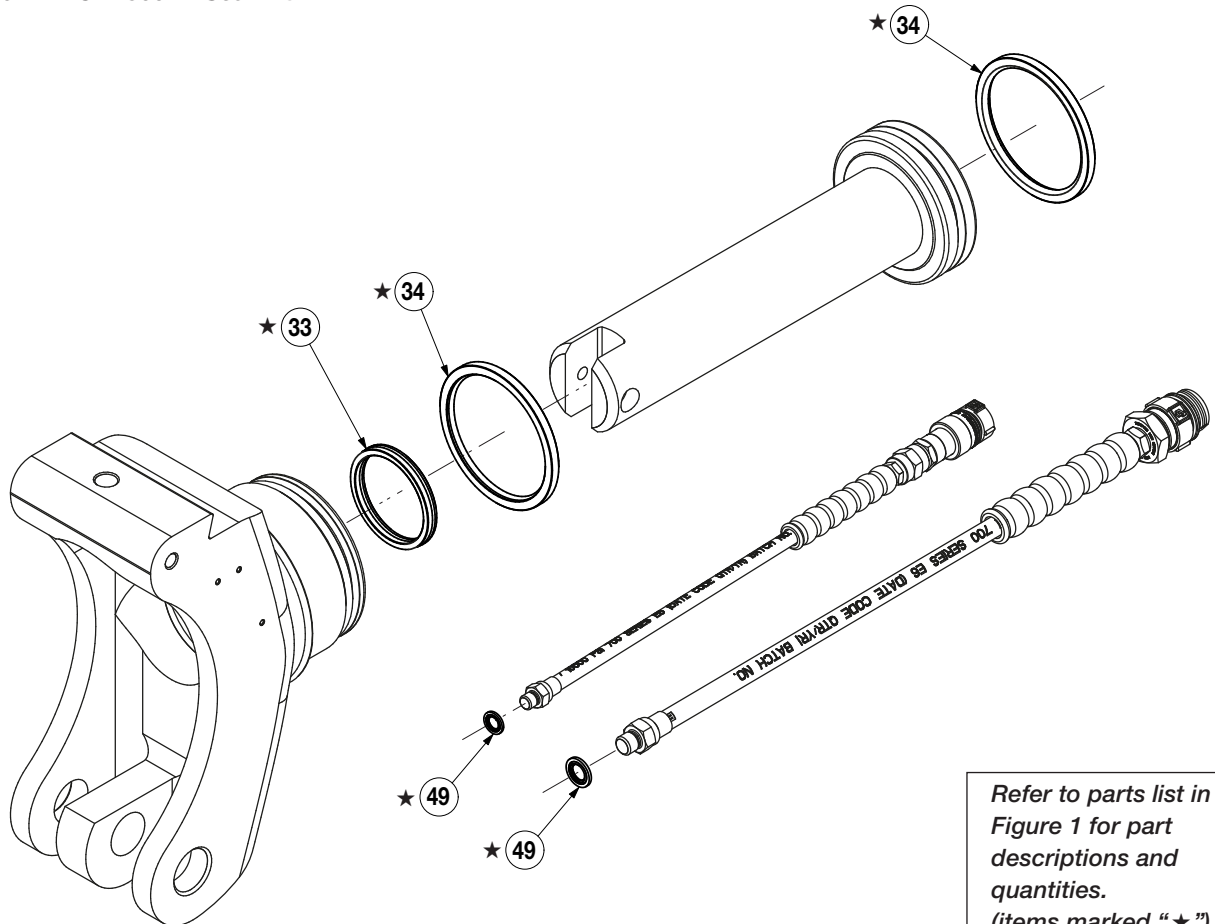

Refer to parts list in Figure 1 for part descriptions and quantities. (items marked "★")

Figure 4 - EWCH18003K Guide Kit

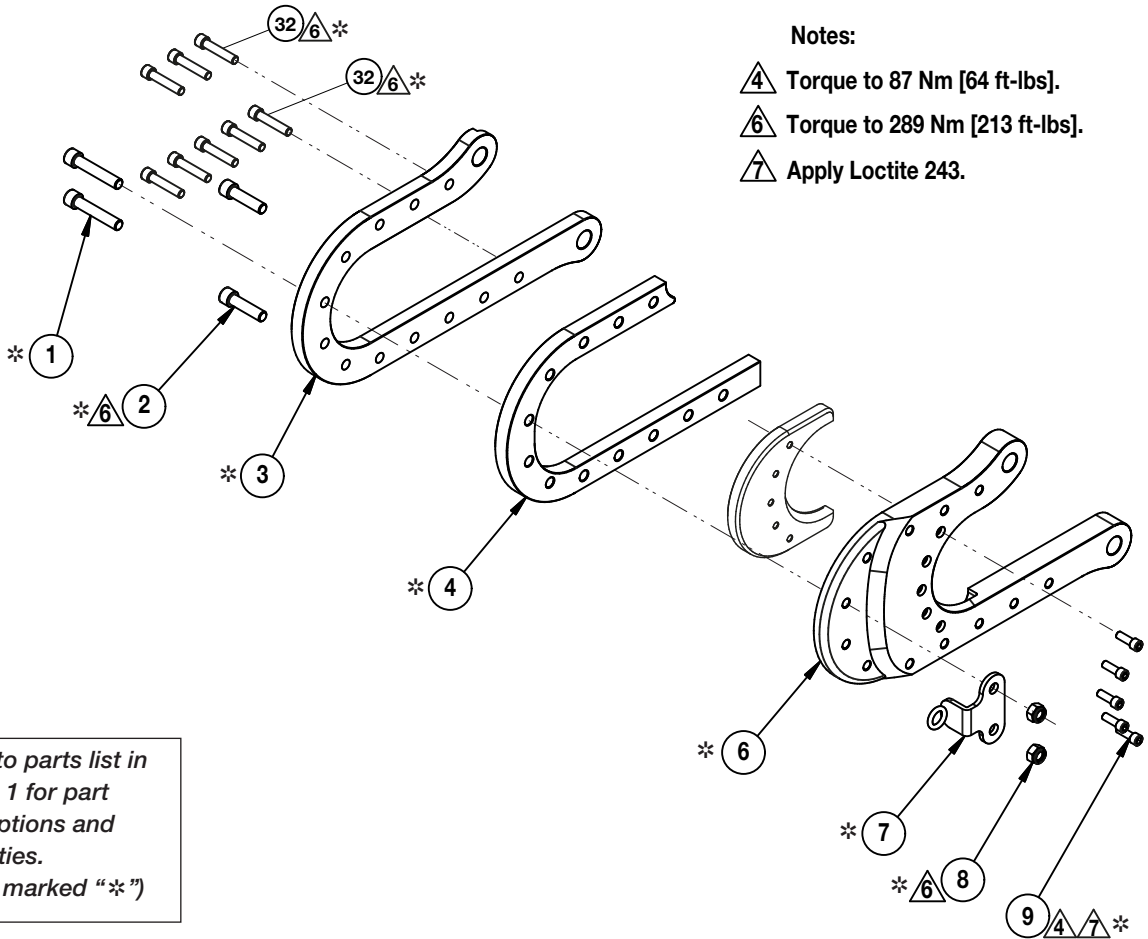

Notes:

- Torque to 87 Nm [64 ft-lbs].
- Torque to 289 Nm [213 ft-lbs].
- Apply Loctite 243.

Refer to parts list in Figure 1 for part descriptions and quantities. (items marked “*”)

Figure 5 - EWCH18004K Lift Kit

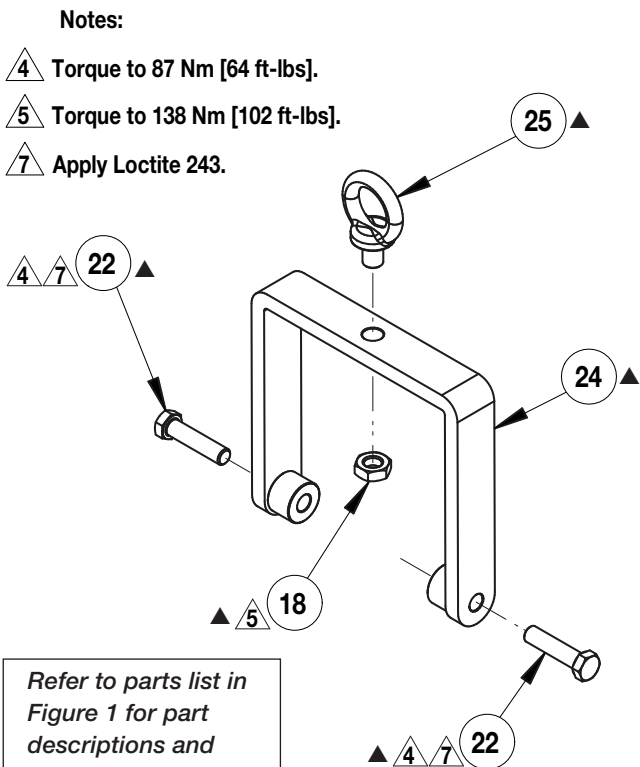

Notes:

- Torque to 87 Nm [64 ft-lbs].
- Torque to 138 Nm [102 ft-lbs].
- Apply Loctite 243.

Refer to parts list in Figure 1 for part descriptions and quantities. (items marked “▲”)

Figure 6 - EWCH18005K Switches Kit

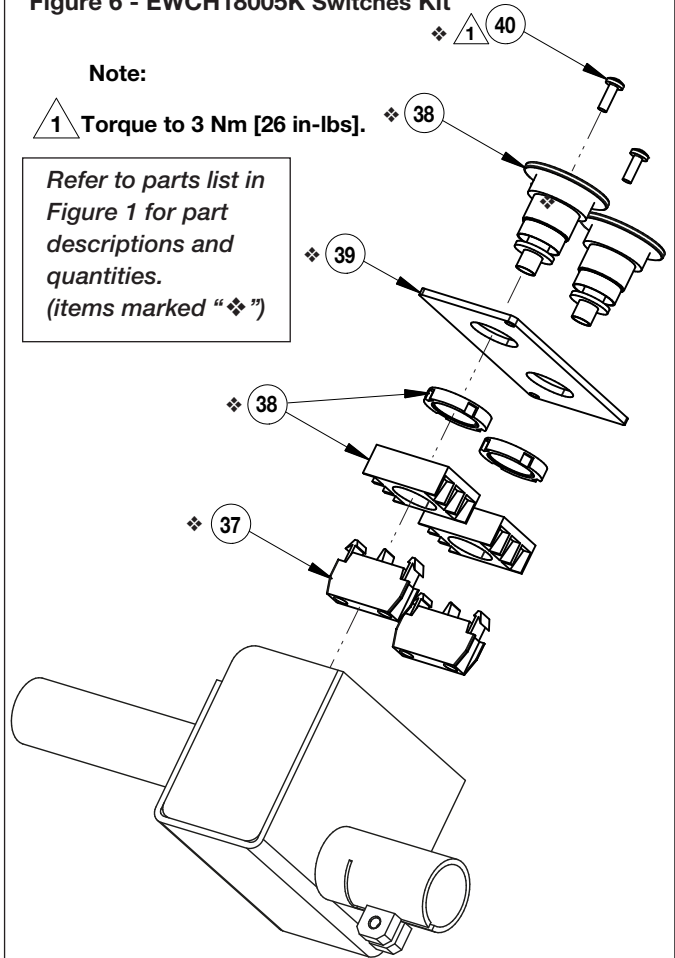

Note:

- Torque to 3 Nm [26 in-lbs].

Refer to parts list in Figure 1 for part descriptions and quantities. (items marked “◆”)

Figure 7 - EWCH18006K Small Parts Kit

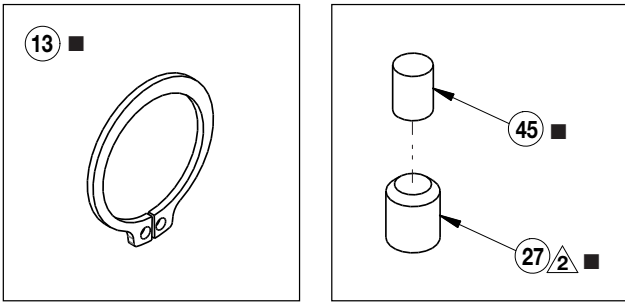

Note:

2 Torque to 10 Nm [91 in-lbs].

Refer to parts list in Figure 1 for part descriptions and quantities. (items marked "■")

Figure 8 - EWCH18007K Head and Cylinder Body Kit

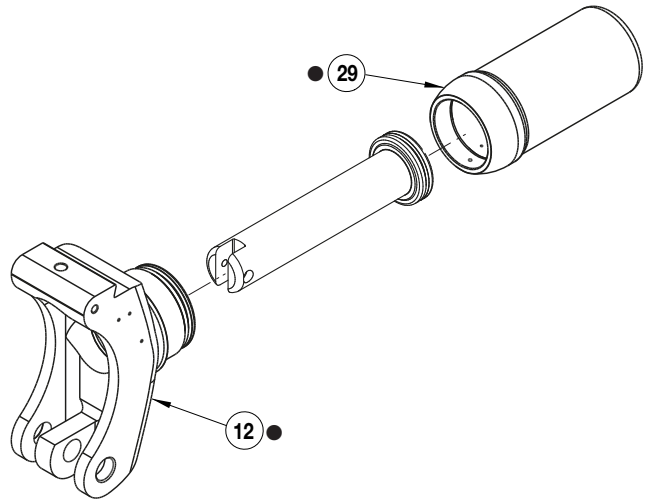

Refer to parts list in Figure 1 for part descriptions and quantities. (items marked "●")

Figure 9 - EWCH18008K Piston Kit

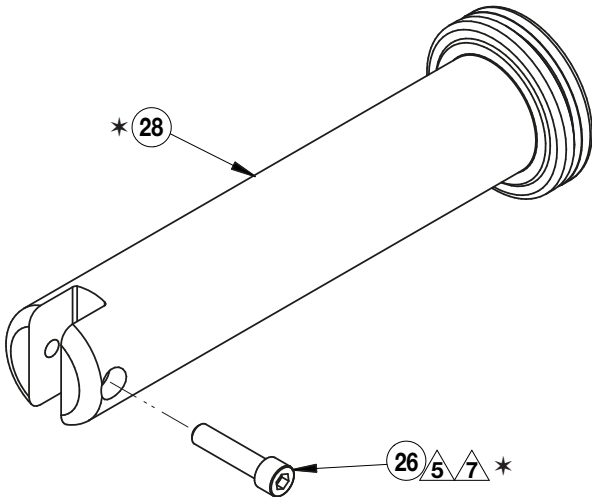

Notes:

5 Torque to 138 Nm [102 ft-lbs].

7 Apply Loctite 243.

Refer to parts list in Figure 1 for part descriptions and quantities. (items marked "*")

Figure 10 - EWCH18009K Pin Kit

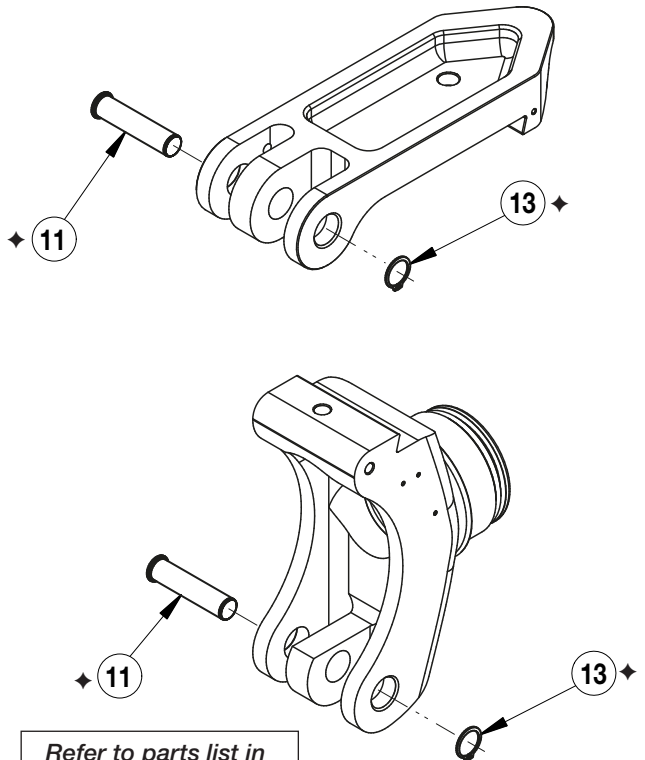

Refer to parts list in Figure 1 for part descriptions and quantities. (items marked "◆")

Figure 11 - EWCH18010K Safety Switch Kit

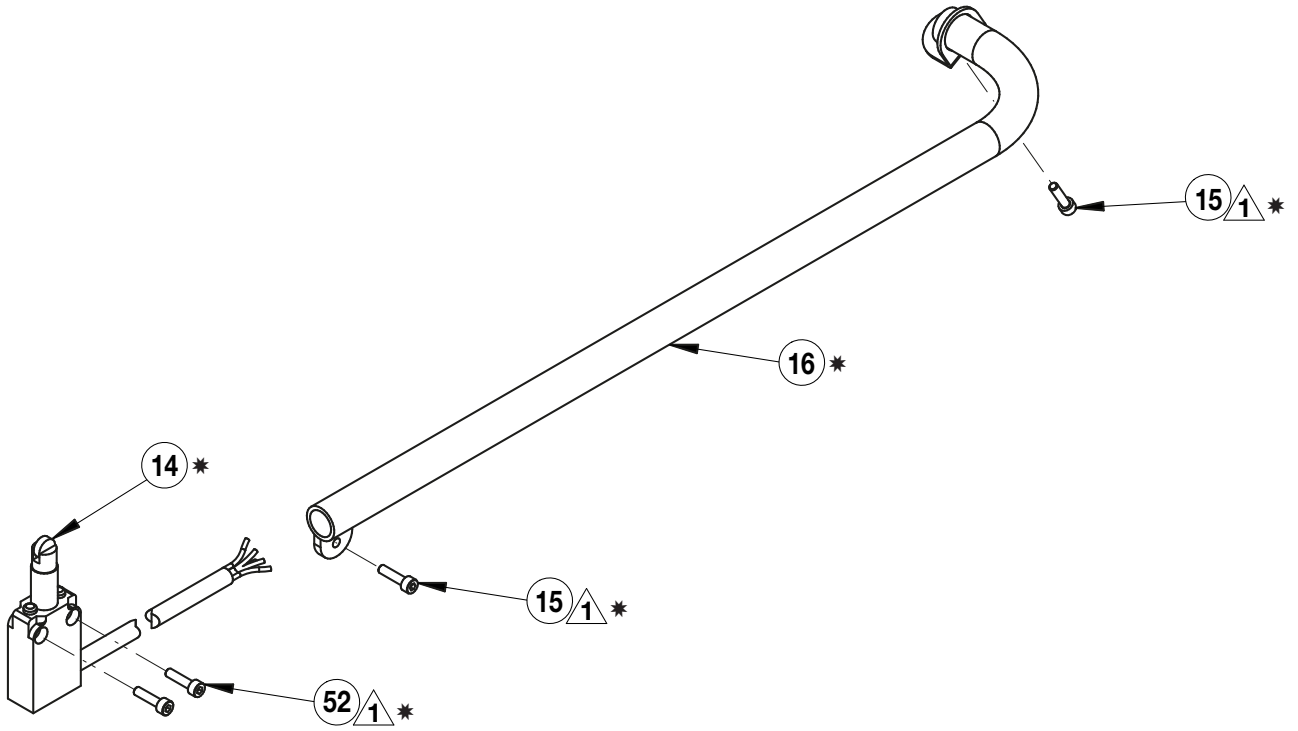

Note:
 ▲ 1 Torque to 3 Nm [26 in-lbs].

Refer to parts list in Figure 1 for part descriptions and quantities. (items marked “*”)

Figure 12 - EWCH18011K Handle Kit

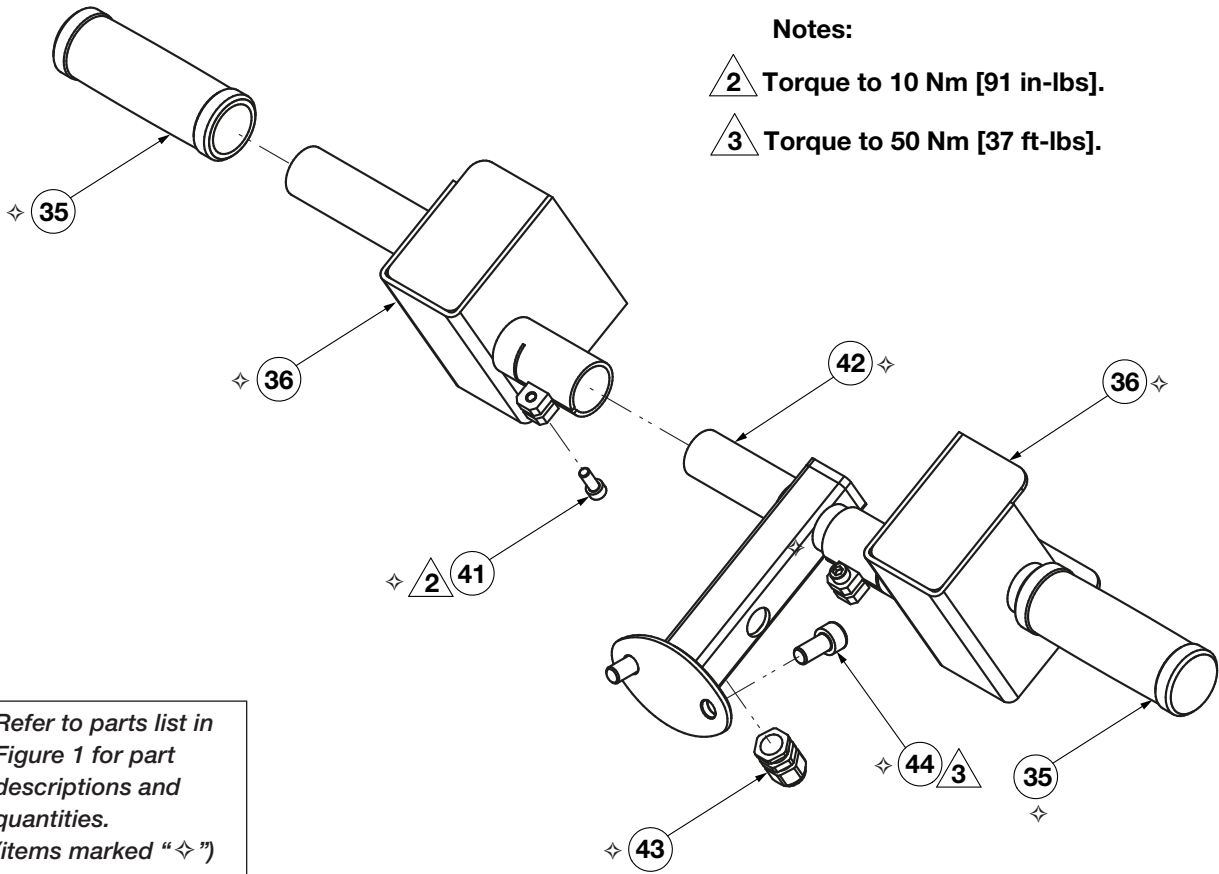

Notes:
 ▲ 2 Torque to 10 Nm [91 in-lbs].
 ▲ 3 Torque to 50 Nm [37 ft-lbs].

Refer to parts list in Figure 1 for part descriptions and quantities. (items marked “◆”)

Figure 13 - EWCH18012K Latch Kit

Notes:

- 2 Torque to 10 Nm [91 in-lbs].
- 4 Torque to 87 Nm [64 ft-lbs].

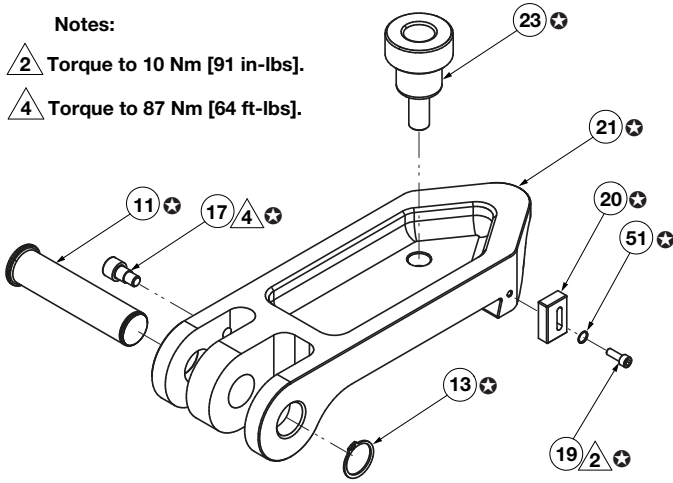

Refer to parts list in Figure 1 for part descriptions and quantities. (items marked "✱")

Figure 14 - EBH5206K Grip Kit

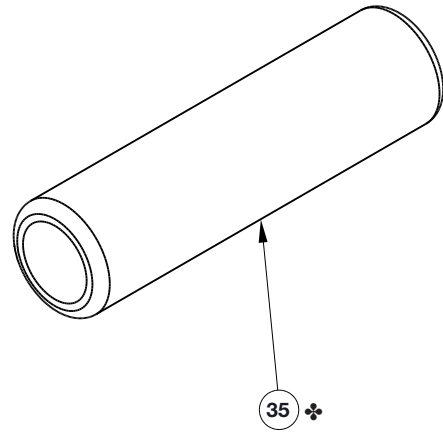

Refer to parts list in Figure 1 for part descriptions and quantities. (items marked "✱")

Figure 15 - ECH500IK Hydraulic Hose Kit.

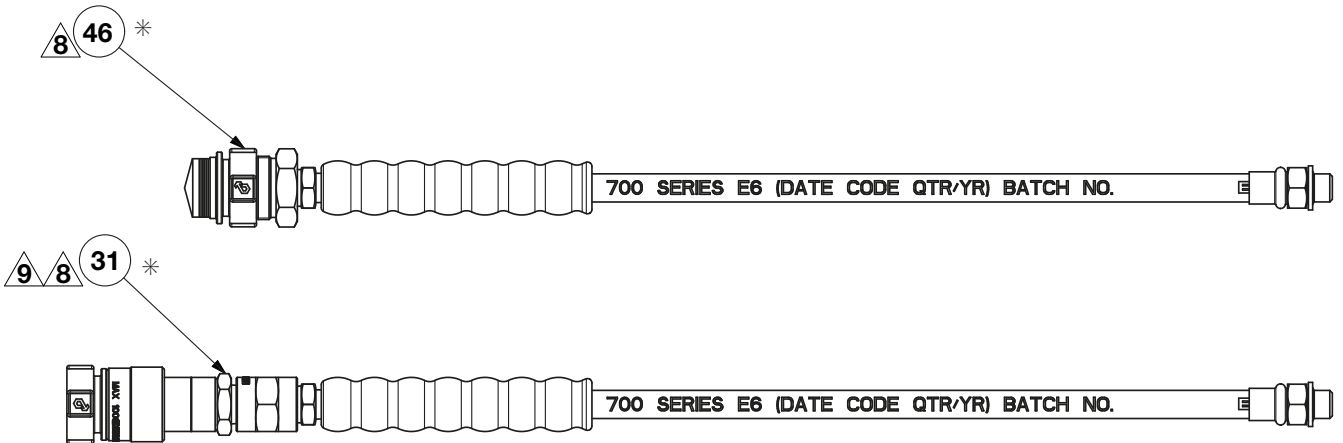

Notes:

- 8 Apply Loctite 542.
- 9 Hose with female quick coupler must be attached to the advance port of the tool.

Refer to parts list in Figure 1 for part descriptions and quantities. (items marked "✱")

Figure 16 - CKECHYD Connector Kit

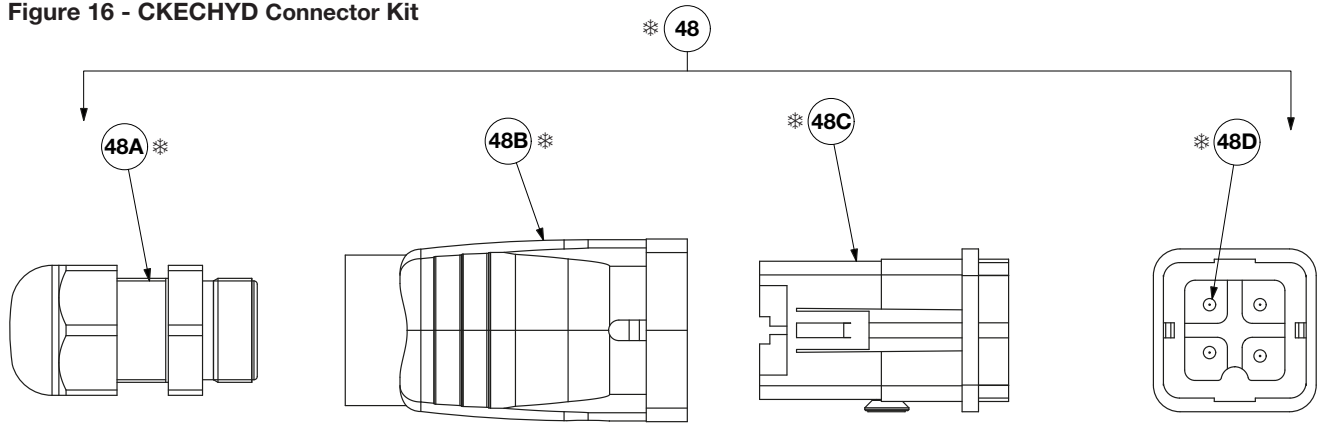

Note:
Items Included in the CKECHYD Kit (item 48):

Item No.	Description
48A	Cable Gland
48B	Housing
48C	Connector
48D	Pins

Figure 17 - CH720EC Hose and Cable Assembly Kit

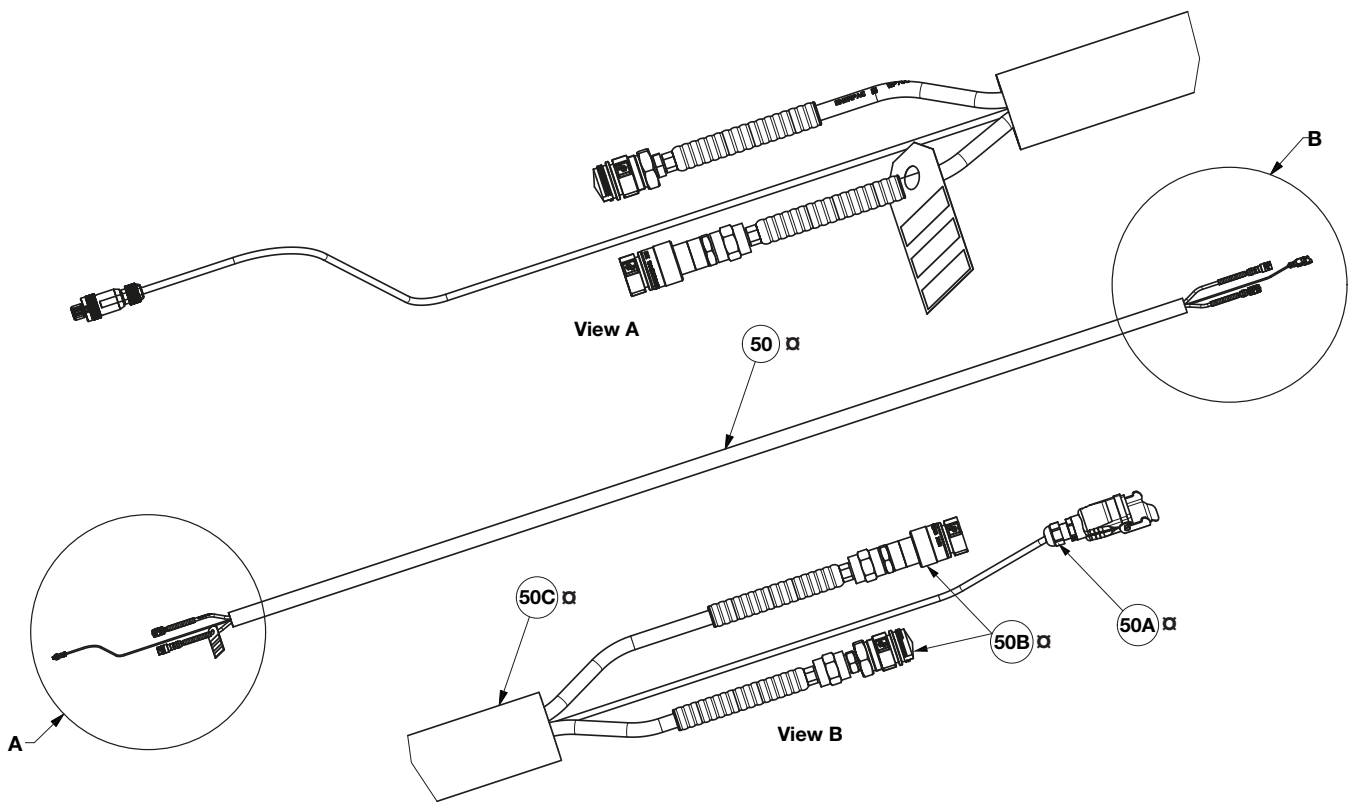

Note:
Items Included in the CH270EC Kit (item 50):

Item No.	Description	Part No.
50A	Electrical Cable	EW720EC
50B	Twin Hydraulic Hose Assy.	CH720MC
50C	Chafe Wrap	S720EC

Figure 18 - DKSCOMP Decal Kit

Notes:

- The decal kit contains decals used on many different cutter models.
- Replace only the decals used on your cutter. Discard the remaining decals in the kit.

