

Document Number	Document Revision	Document Revision Date	Product Date Code Beginning With
L4337	C	07/2019	A

**To Protect Your Warranty, Use Only ENERPAC Hydraulic Oil.**

Enerpac recommends that all kit components be installed to insure optimum performance of the repaired product.

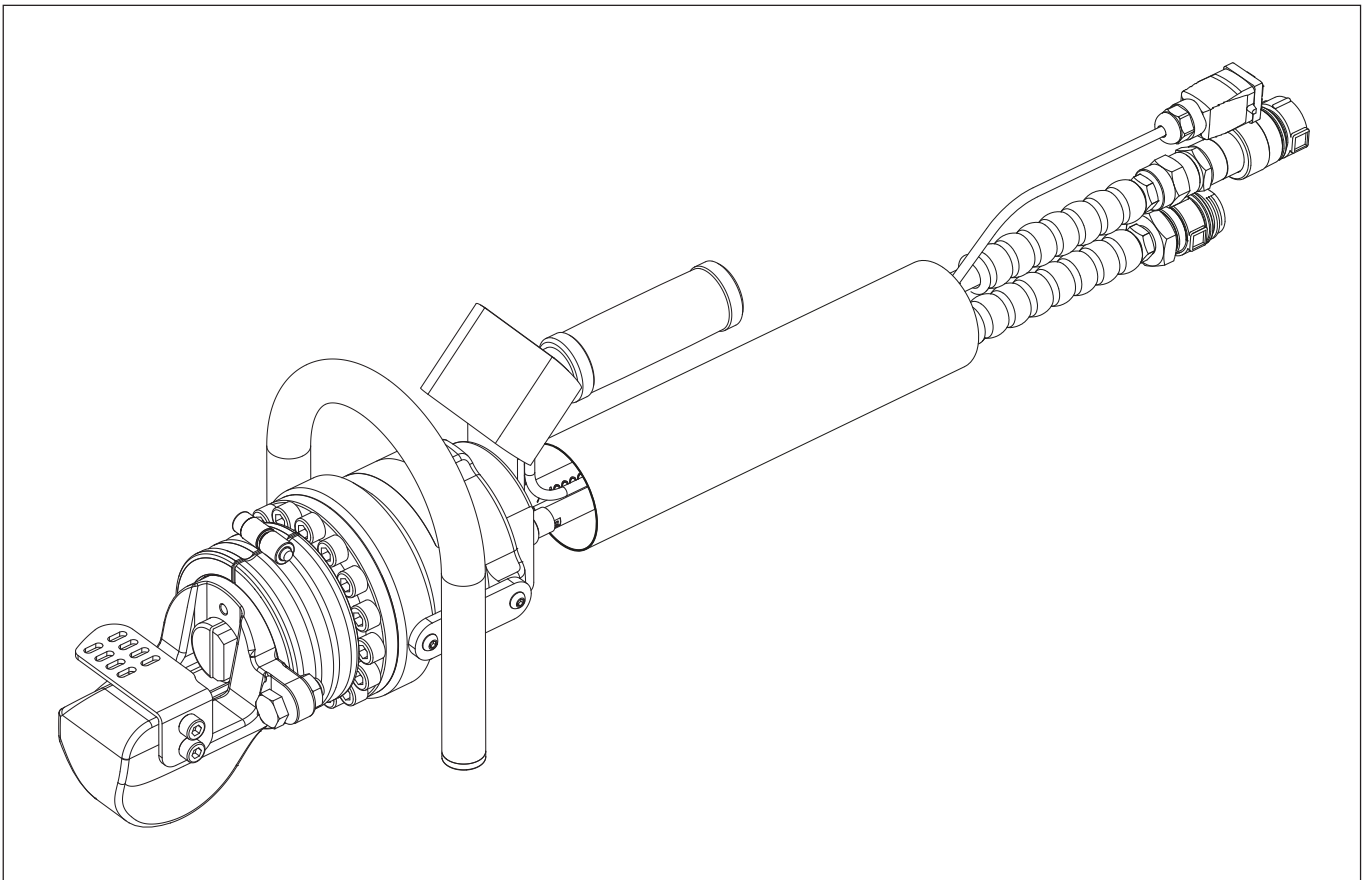

**Table of Contents:**

	Page		Page
Figure 1 - EBH30 Cutter, Exploded View	2	Figure 11 - EBH3010K Cylinder Bottom Kit	7
Figure 2 - EBH3001K Blade Kit	4	Figure 12 - EBH3011K Small Parts Kit	8
Figure 3 - EBH3002K Seal Kit	4	Figure 13 - EBH3012K Cylinder Body Kit	8
Figure 4 - EBH3003K Collar Kit	5	Figure 14 - EBH3013K Head Kit	8
Figure 5 - EBH3004K Lift Kit	5	Figure 15 - EBH5204K Switch Kit	9
Figure 6 - EBH3005K Handle Kit	5	Figure 16 - ECH5001K Hydraulic Hose Kit	9
Figure 7 - EBH3006K Grip Kit	6	Figure 17 - CKECHYD Connector Kit	10
Figure 8 - EBH3007K Guard Kit	6	Figure 18 - CH720EC Hose and Cable Assembly Kit	10
Figure 9 - EBH3008K Flange Kit	6	Figure 19 - DKSCOMP Decal Kit	11
Figure 10 - EBH3009K Piston Kit	7		

**⚠ WARNING** Be certain that hydraulic pressure is completely relieved (0 psi/bar) before beginning any adjustment, maintenance or repair procedures. Appropriate shop safety procedures are to be followed during disassembly and reassembly to minimize any possibility of injury.

**Note:** Parts kits, components and product features described in this document are subject to change without notice.

Figure 1 - EBH30 Cutter, Exploded View

Notes:

- ▲ 1 Torque to 50 Nm [37 ft-lbs].
- ▲ 2 Torque to 10 Nm [91 in-lbs].
- ▲ 3 Torque to 25 Nm [18 ft-lbs].
- ▲ 4 Torque to 3 Nm [26 in-lbs].
- ▲ 5 Torque to 5.98 Nm [52.9 in-lbs].
- ▲ 6 Apply Loctite 243.
- ▲ 9 Hose with female quick coupler must be attached to the advance part of the tool.

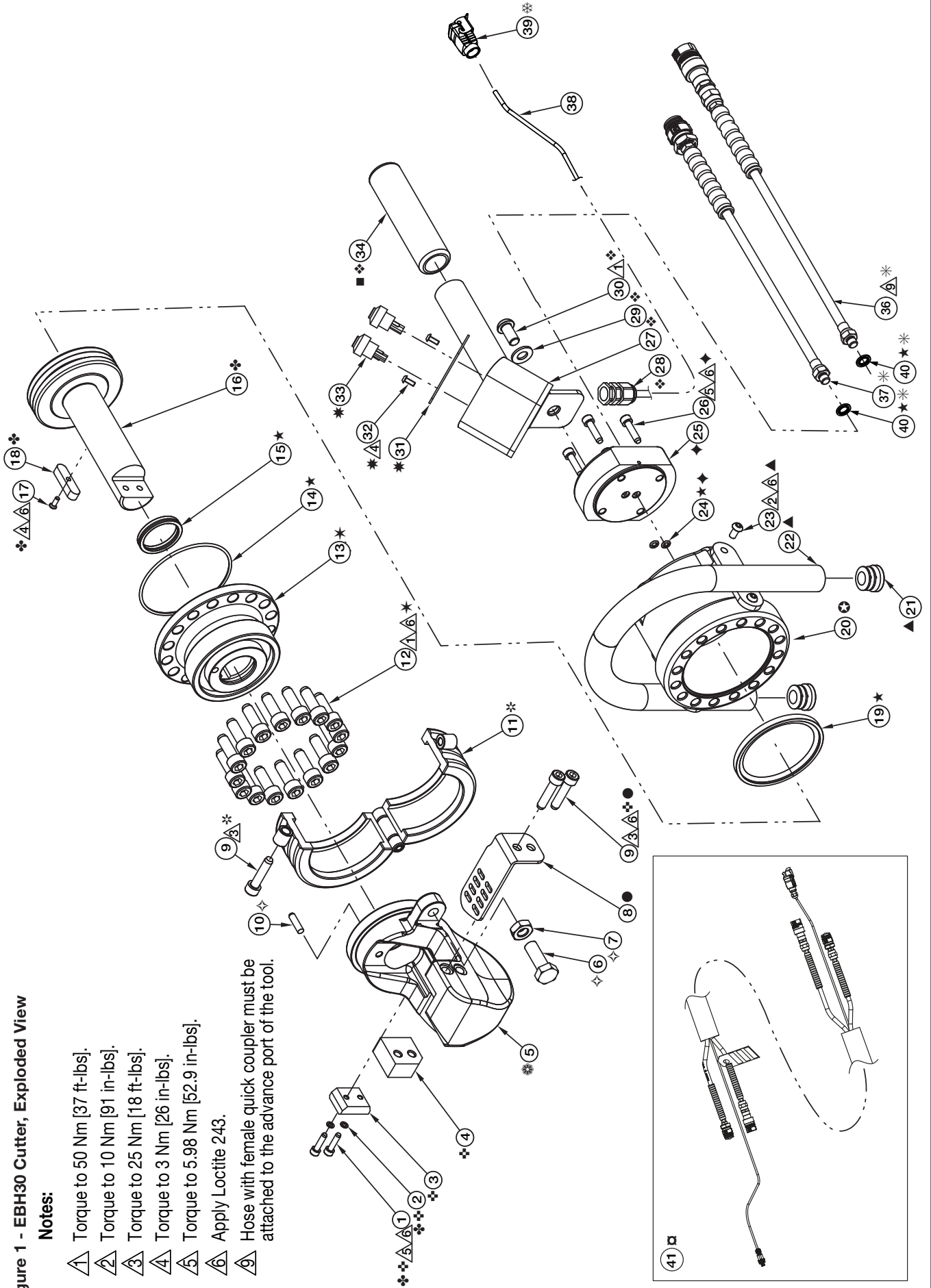

Repair Parts List for Figure 1			
Item No.	Part Number	Qty.	Description
1	❖❖	2	Socket head screw M5 x 20 UNI 5931 Zn
2	❖❖	2	Lock washer M5 Zn
3	❖	1	Moving blade
4	❖	1	Fixed blade
5	⊗	1	Head
6	◇	1	Screw M12 x 35 UNI 5739 Zn
7	◇	1	Nut M12 5589 Zn
8	●	1	Guard
9	❖❖❖	3	Socket head screw M8 x 35 UNI 5931 Zn
10	◇	1	Pin 6 x 24
11	*	1	Mounting ring assembly
12	*	16	Socket head screw M10 x 30 UNI 5931 Zn
13	*	1	Mounting flange
14	*	1	O-Ring 88.57 x 2.62
15	*	1	Gasket CSC 4436
16	❖	1	Piston
17	❖	1	Hex socket countersunk head screw M4 x 14 10.9 UNI 5931 Zn
18	❖	1	Key 10 x 8 x 40
19	*	1	Gasket NPU 90 x 74 x 6.3
20	⊗	1	Cylinder
21	▲	2	Plastic plug
22	▲	1	Handle assembly
23	▲	4	Button head screw M6 x 12 UNI 7380 Zn
24	★◆	2	O-Ring 4.48 x 1.78 90 SH
25	◆	1	Bottom
26	◆	4	Socket cap screw M6 x 35 UNI 5931 Zn
27	❖	1	Handle assembly
28	❖	1	Cable gland
29	❖	1	Washer M10 UNI 6592 Zn
30	❖	1	Screw M10 x 20 UNI 7380 Zn
31	*	1	Button panel
32	*	2	Button screw M4 x 10 UNI 7380 Zn

Repair Parts List for Figure 1 (Continued)			
Item No.	Part Number	Qty.	Description
33	*	2	Push Button Switch
34	❖■	1	Grip
36	*	1	High press. hose (700 Series) G 1/4 M + DC1392900
37	*	1	High press. hose (700 Series) G 1/4 M + C.J649096
38	N/A	1	Control Cable
39	*	1	Connector
40	★*	2	Bonded seal washer (included with items 36 and 37)
41	▣	1	Hose and Cable Assembly, 6m long

Kit Information		
Symbol	Included In	See Figure
❖	EBH3001K Blade Kit	2
★	EBH3002K Seal Kit	3
*	EBH3003K Collar Kit	4
▲	EBH3004K Lift Kit	5
❖	EBH3005K Handle Kit	6
■	EBH3006K Grip Kit	7
●	EBH3007K Guard Kit	8
*	EBH3008K Flange Kit.	9
❖	EBH3009K Piston Kit	10
◆	EBH3010K Cylinder Bottom Kit	11
◇	EBH3011K Small Parts Kit	12
⊗	EBH3012K Cylinder Body Kit	13
⊗	EBH3013K Head Kit	14
*	EBH5204K Switch Kit	15
*	ECH500IK Hydraulic Hose Kit	16
*	CKECHYD Connector Kit	17
▣	CH720EC Hose and Cable Assembly Kit	18
N/A	DKSCOMP Decal Kit	19

Refer to figures 2 through 19 for kit part exploded views and additional service information.

N/A - Not Available

**Figure 2 - EBH3001K Blade Kit**

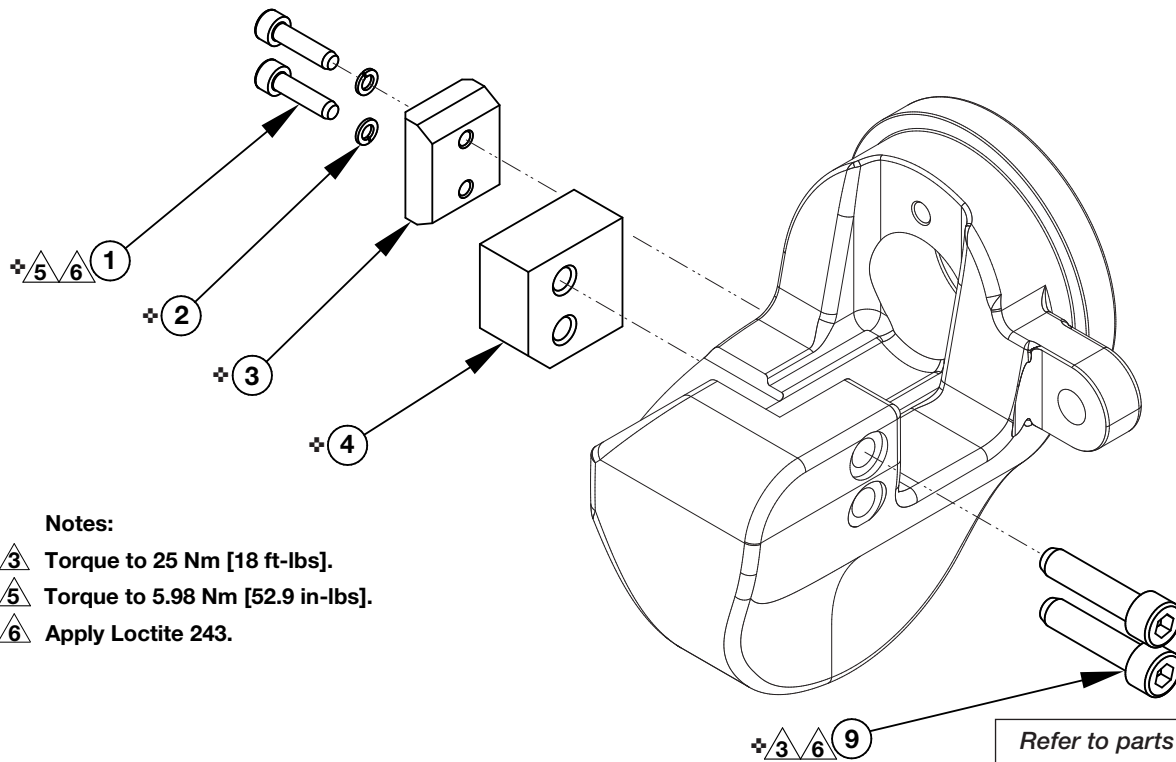

**Notes:**

- ▲ 3 Torque to 25 Nm [18 ft-lbs].
- ▲ 5 Torque to 5.98 Nm [52.9 in-lbs].
- ▲ 6 Apply Loctite 243.

Refer to parts list in Figure 1 for part descriptions and quantities. (items marked “+”)

**Figure 3 - EBH3002K Seal Kit**

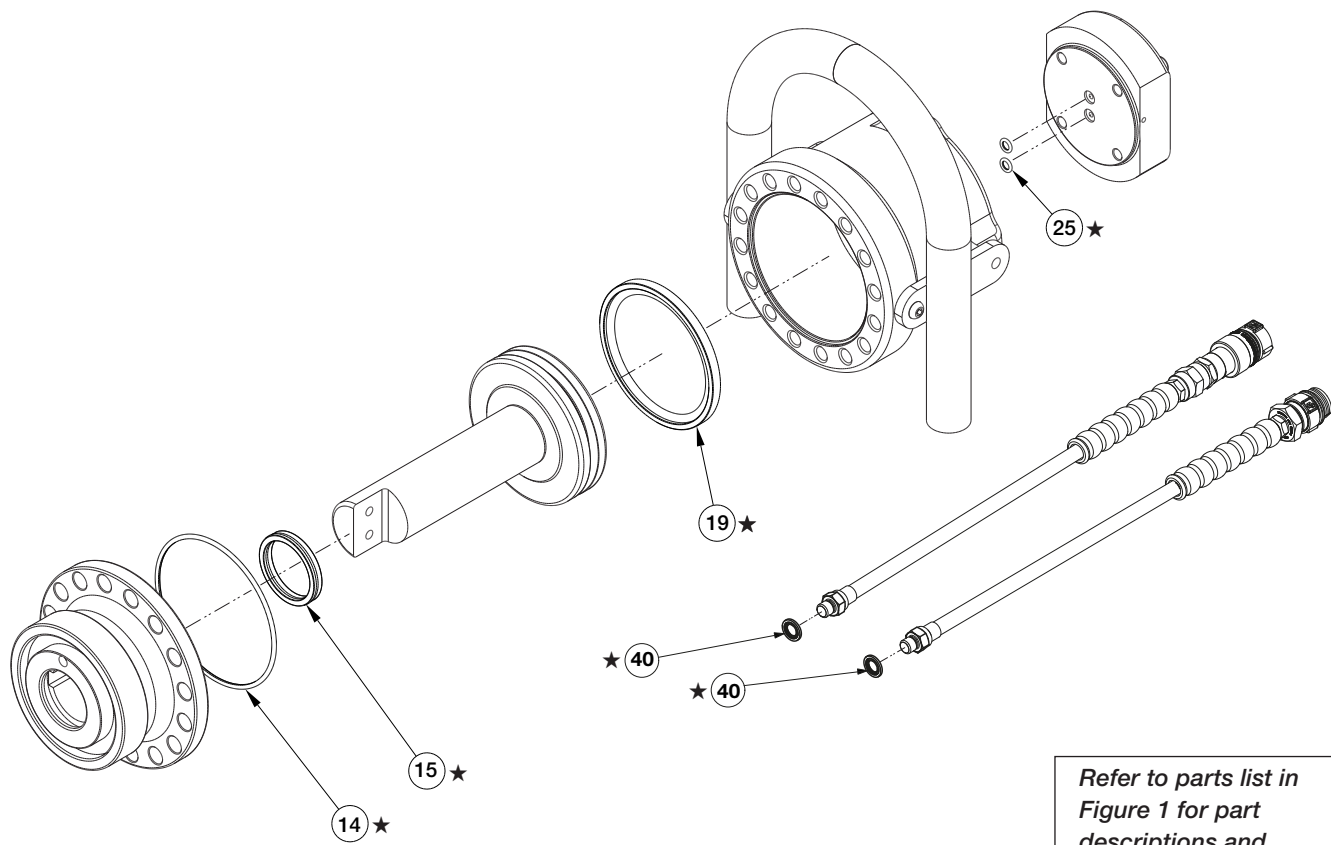

Refer to parts list in Figure 1 for part descriptions and quantities. (items marked “★”)

Figure 4 - EBH3003K Collar Kit

Notes:  
 ▲<sup>3</sup> Torque to 25 Nm [18 ft-lbs].

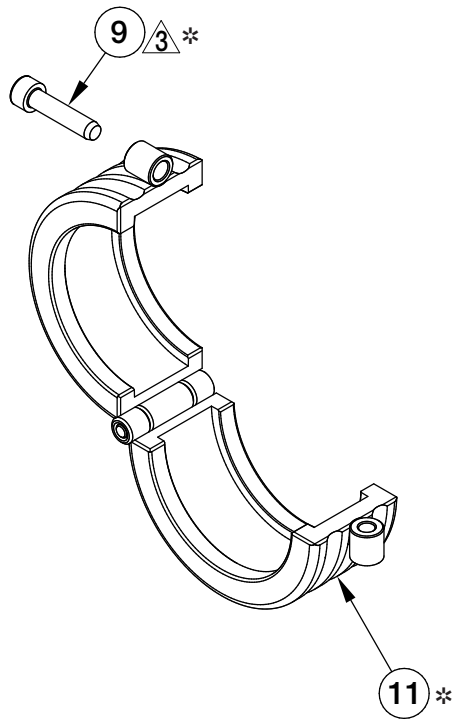

Refer to parts list in Figure 1 for part descriptions and quantities. (items marked “\*”)

Figure 5 - EBH3004K Lift Kit

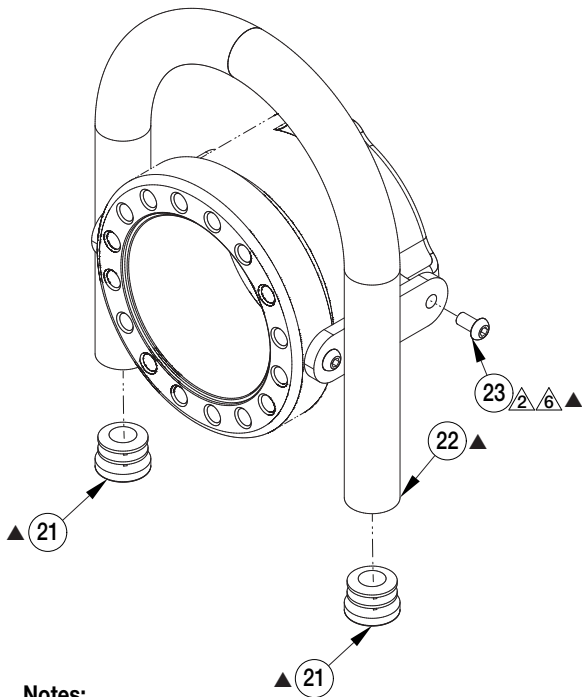

Notes:  
 ▲<sup>2</sup> Torque to 10 Nm [91 in-lbs].  
 ▲<sup>6</sup> Apply Loctite 243.

Refer to parts list in Figure 1 for part descriptions and quantities. (items marked “▲”)

Figure 6 - EBH3005K Handle Kit

Note:  
 ▲<sup>1</sup> Torque to 50 Nm [37 ft-lbs].

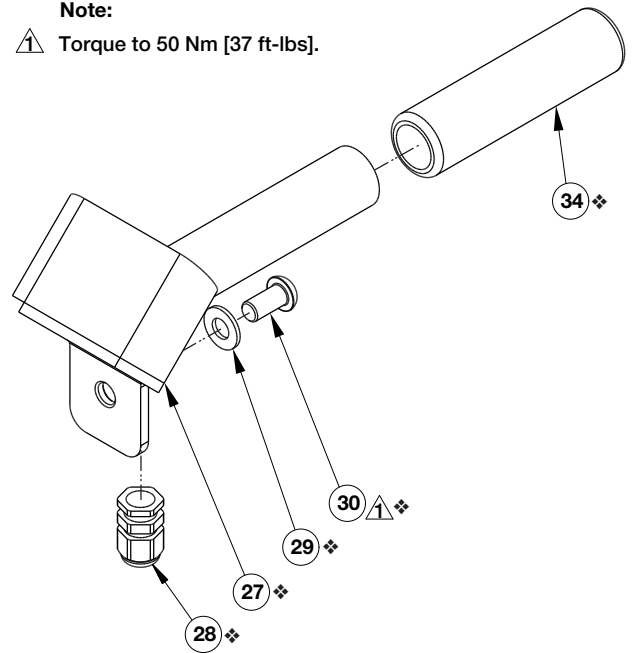

Refer to parts list in Figure 1 for part descriptions and quantities. (items marked “\*”)

Figure 7 - EBH3006K Grip Kit

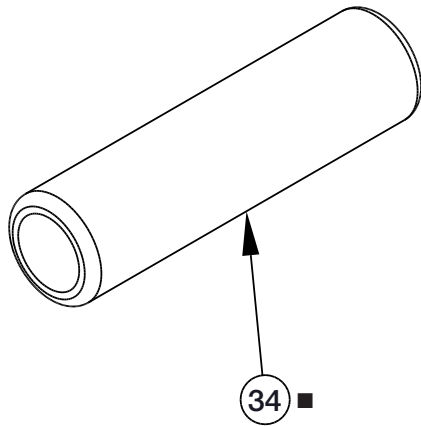

Refer to parts list in Figure 1 for part descriptions and quantities. (items marked "■")

Figure 8 - EBH3007K Guard Kit

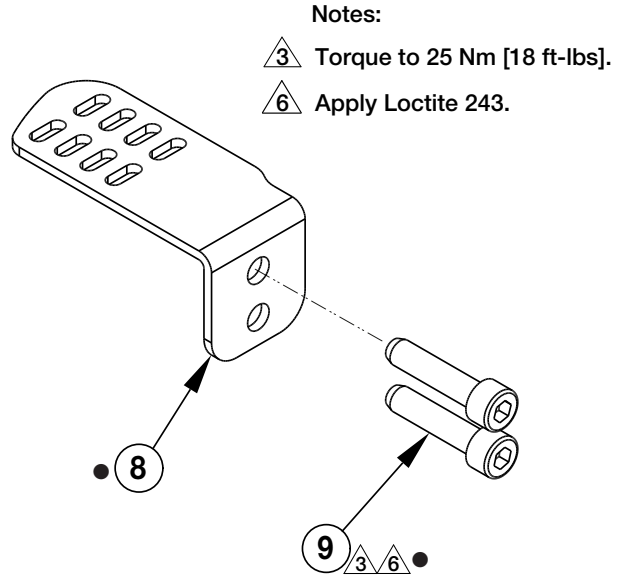

Refer to parts list in Figure 1 for part descriptions and quantities. (items marked "●")

Figure 9 - EBH3008K Flange Kit

- Notes:  
 5 Torque to 50 Nm [37 ft-lbs].  
 6 Apply Loctite 243.

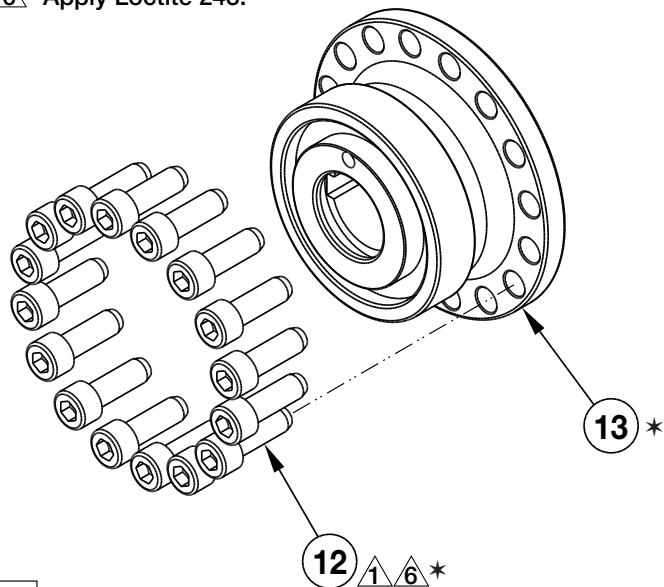

Refer to parts list in Figure 1 for part descriptions and quantities. (items marked "\*")

Figure 10 - EBH3009K Piston Kit

Note:

- ▲ Torque to 3 Nm [26 in-lbs].
- ▲ Torque to 5.98 Nm [52.9 in-lbs].
- ▲ Apply Loctite 243.

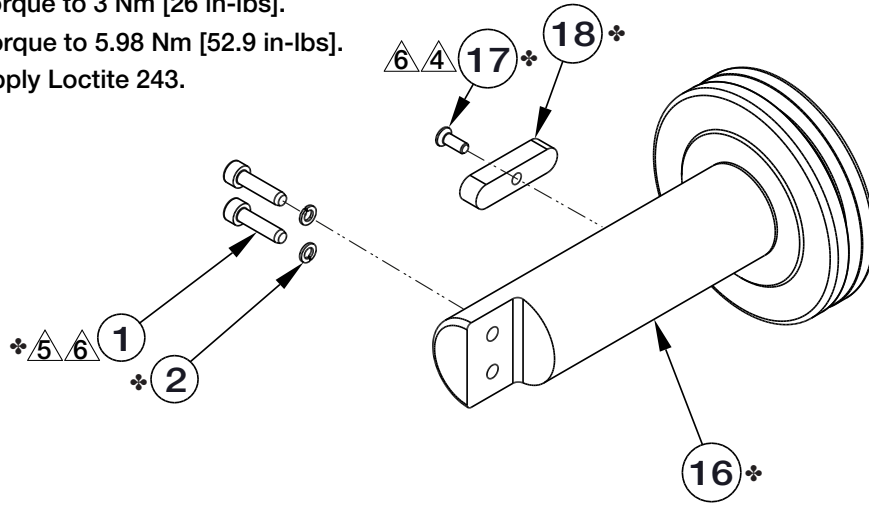

Refer to parts list in Figure 1 for part descriptions and quantities. (items marked "❖")

Figure 11 - EBH3010K Cylinder Bottom Kit

Note:

- ▲ Torque to 5.98 Nm [52.9 in-lbs].
- ▲ Apply Loctite 243.

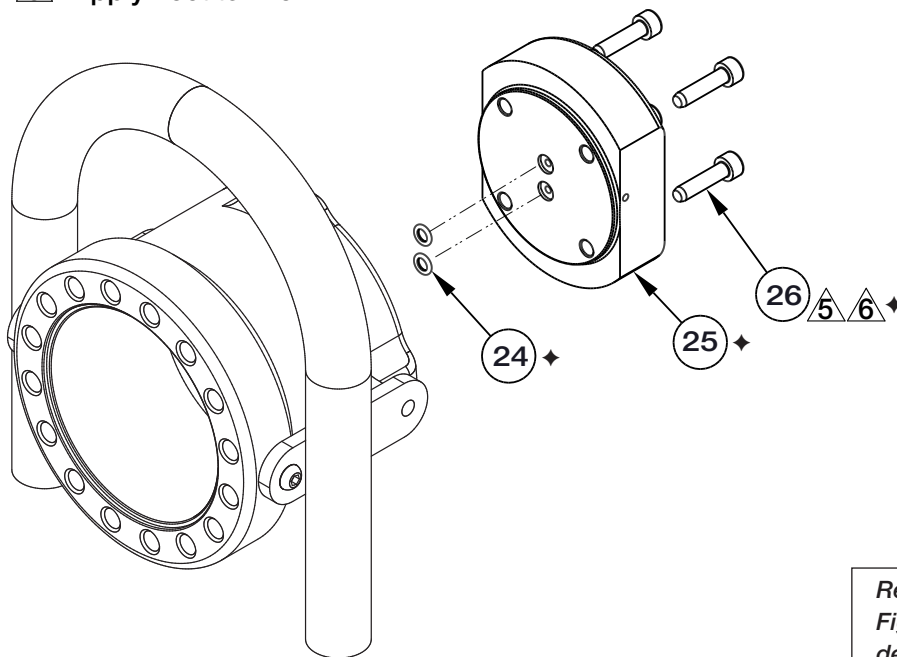

Refer to parts list in Figure 1 for part descriptions and quantities. (items marked "❖")

Figure 12 - EBH3011K Small Parts Kit

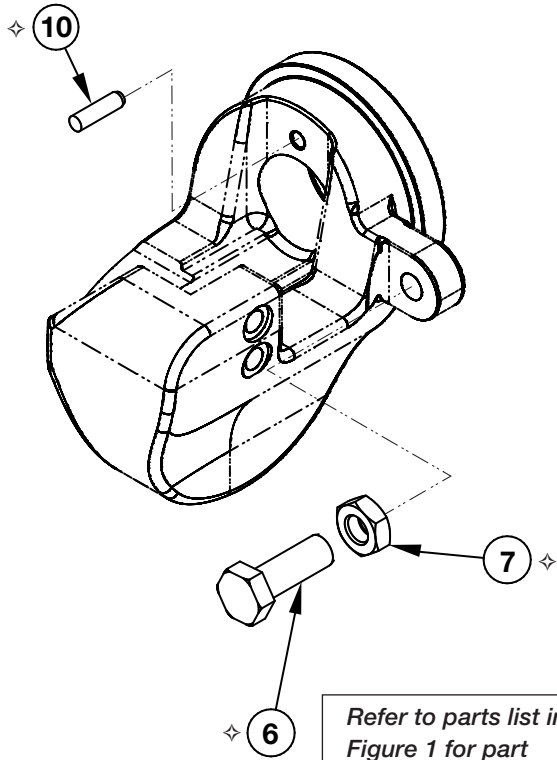

Refer to parts list in Figure 1 for part descriptions and quantities. (items marked “◆”)

Figure 13 - EBH3012K Cylinder Body Kit

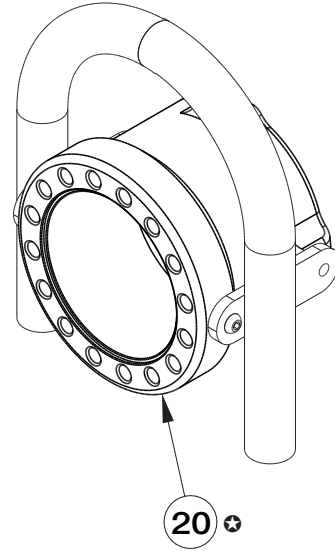

Refer to parts list in Figure 1 for part descriptions and quantities. (items marked “⊕”)

Figure 14 - EBH3013K Head Kit.

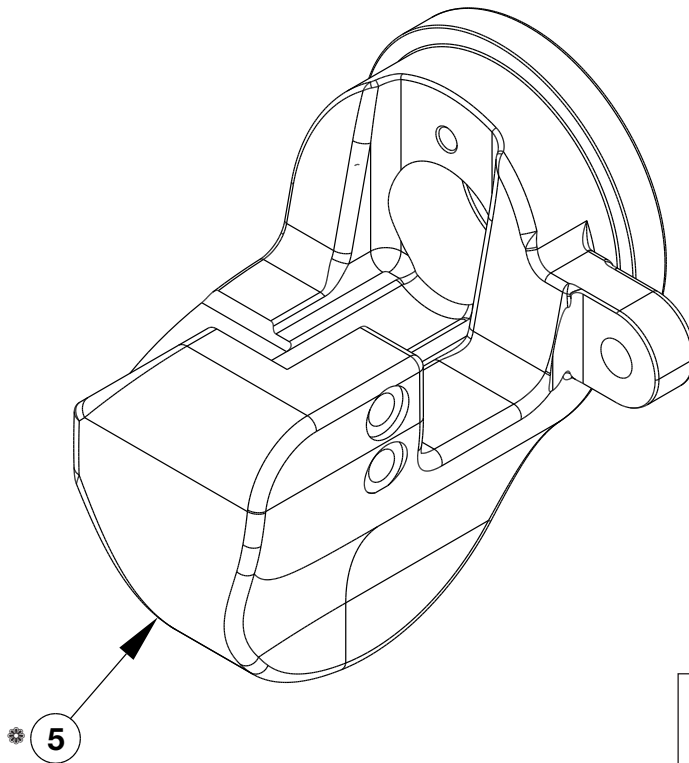

Refer to parts list in Figure 1 for part descriptions and quantities. (items marked “⊗”)



Figure 15 - EBH5204K Switch Kit.

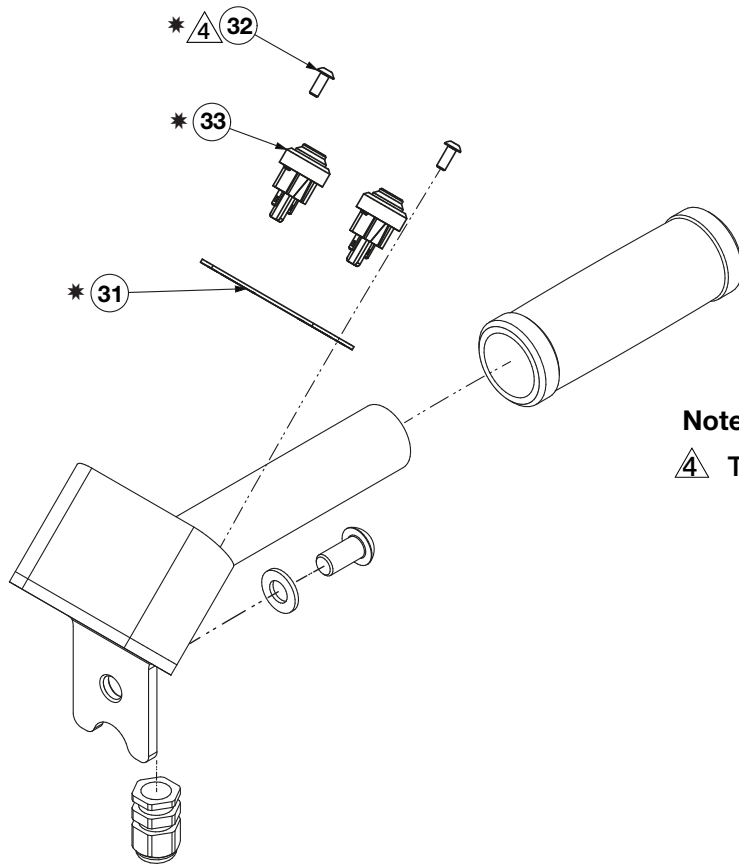

**Note:**

 Torque to 3 Nm [26 in-lbs].

*Refer to parts list in Figure 1 for part descriptions and quantities. (items marked “\*”)*

Figure 16 - ECH500IK Hydraulic Hose Kit.

**Note:**

 Hose with female quick coupler must be attached to the advance port of the tool.

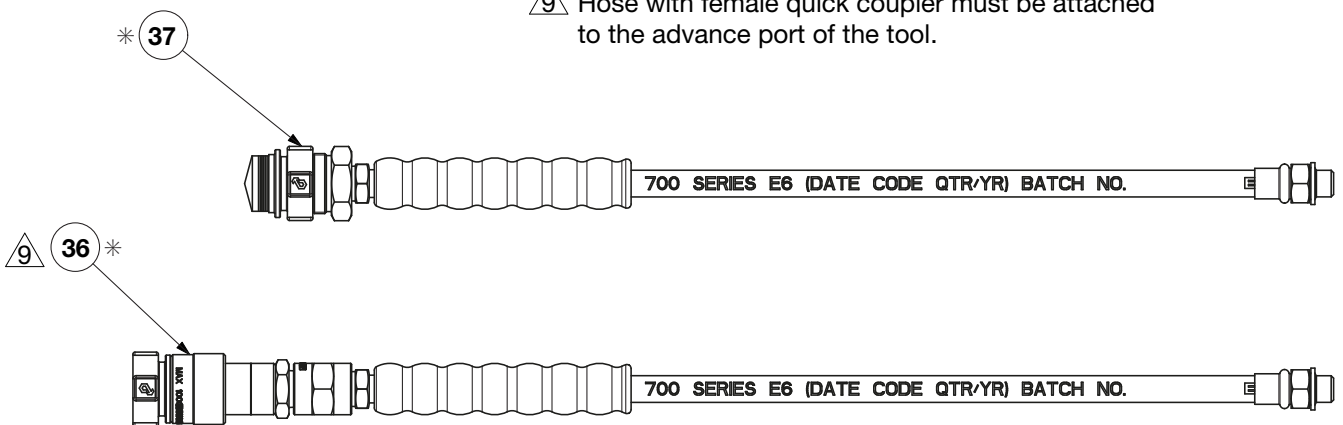

*Refer to parts list in Figure 1 for part descriptions and quantities. (items marked “\*”)*

Figure 17 - CKECHYD Connector Kit

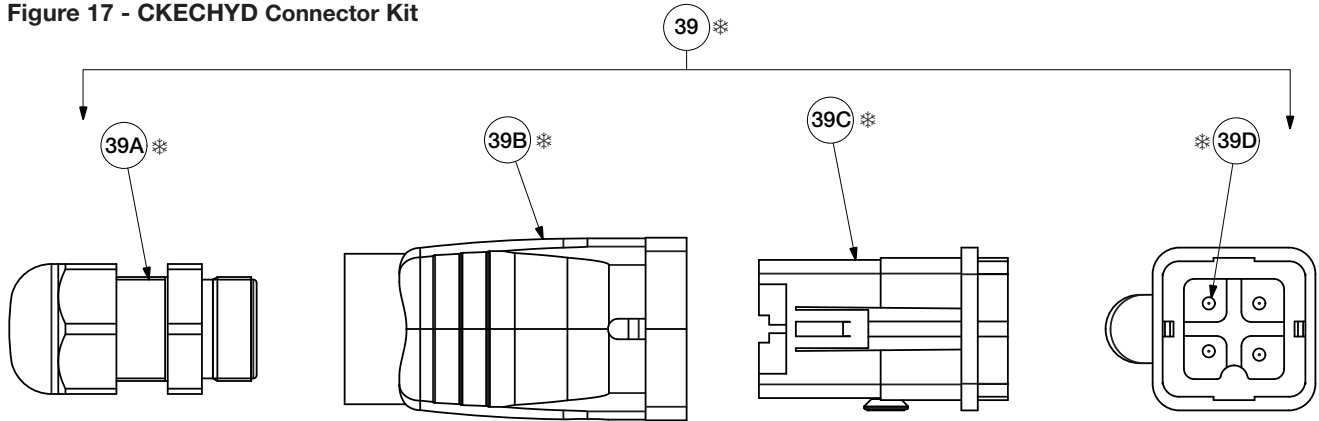

**Note:**  
Items Included in the CKECHYD Kit (item 39):

Item No.	Description
39A	Cable Gland
39B	Housing
39C	Connector
39D	Pins

Figure 18 - CH720EC Hose and Cable Assembly Kit

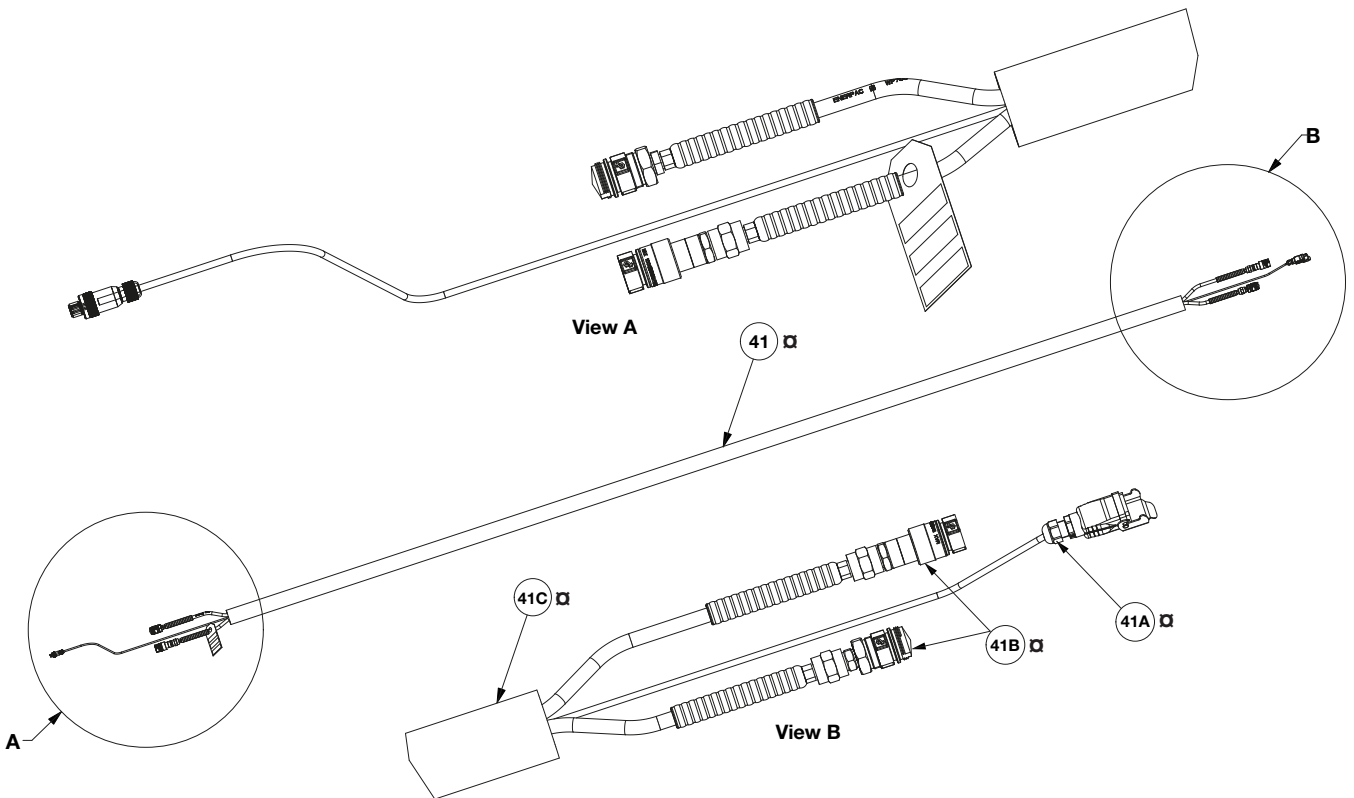

**Note:**  
Items Included in the CH270EC Kit (item 41):

Item No.	Description	Part No.
41A	Electrical Cable	EW720EC
41B	Twin Hydraulic Hose Assy.	CH720MC
41C	Chafe Wrap	S720EC

**Notes:**

- The decal kit contains decals used on many different cutter models.
- Replace only the decals used on your cutter. Discard the remaining decals in the kit.

