

Document Number	Document Revision	Document Revision Date	Product Date Code Beginning With
L4338	C	07/2019	A

**To Protect Your Warranty, Use Only ENERPAC Hydraulic Oil.**

Enerpac recommends that all kit components be installed to insure optimum performance of the repaired product.

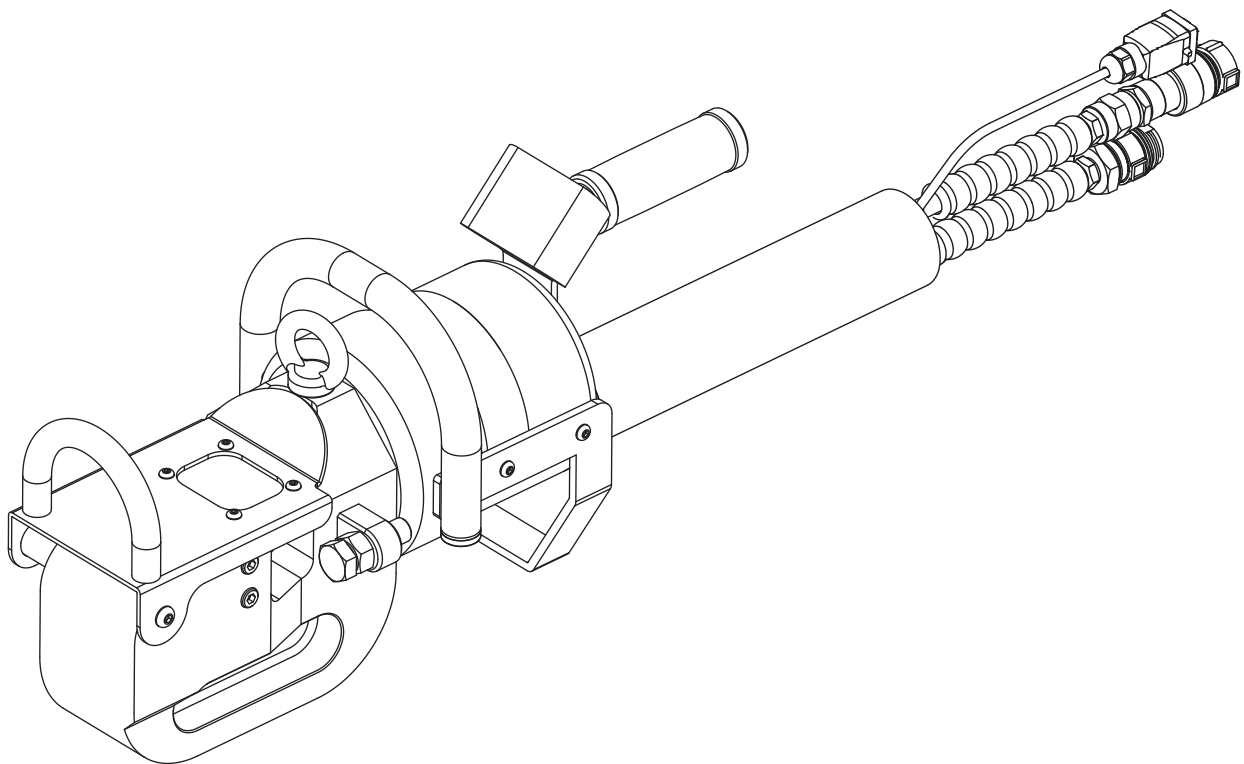

#### Table of Contents:

	Page		Page
Figure 1 - EBH35 Cutter, Exploded View	2	Figure 9 - EBH3508K Guard Window Kit	6
Figure 2 - EBH3501K Blade Kit	4	Figure 10 - EBH5204K Switches Kit	7
Figure 3 - EBH3502K Seal Kit	4	Figure 11 - EBH5205K Handle Kit	7
Figure 4 - EBH3503K Small Parts Kit	5	Figure 12 - EBH5206K Grip Kit	8
Figure 5 - EBH3504K Lift Kit	5	Figure 13 - ECH500IK Hydraulic Hose Kit	8
Figure 6 - EBH3505K Head and Cylinder Body Kit	5	Figure 14 - CKECHYD Connector Kit	9
Figure 7 - EBH3506K Piston Kit	6	Figure 15 - CH720EC Hose and Cable Assembly Kit	9
Figure 8 - EBH3507K Guard Kit	6	Figure 16 - DKSCOMP Decal Kit	10

**⚠ WARNING** Be certain that hydraulic pressure is completely relieved (0 psi/bar) before beginning any adjustment, maintenance or repair procedures. Appropriate shop safety procedures are to be followed during disassembly and reassembly to minimize any possibility of injury.

**Note:** Parts kits, components and product features described in this document are subject to change without notice.

Figure 1 - EBH35 Cutter, Exploded View

Notes:

- ▲ Torque to 50 Nm [37 ft-lbs].
- ▲ Torque to 10 Nm [91 in-lbs].
- ▲ Torque to 25 Nm [18 ft-lbs].
- ▲ Torque to 3 Nm [26 in-lbs].
- ▲ Torque to 5.98 Nm [52.9 in-lbs].
- ▲ Torque until guard moves with appropriate friction.
- ▲ Apply Loctite 243.
- ▲ Apply Loctite 542.
- ▲ Hose with female quick coupler must be attached to the advance port of the tool.

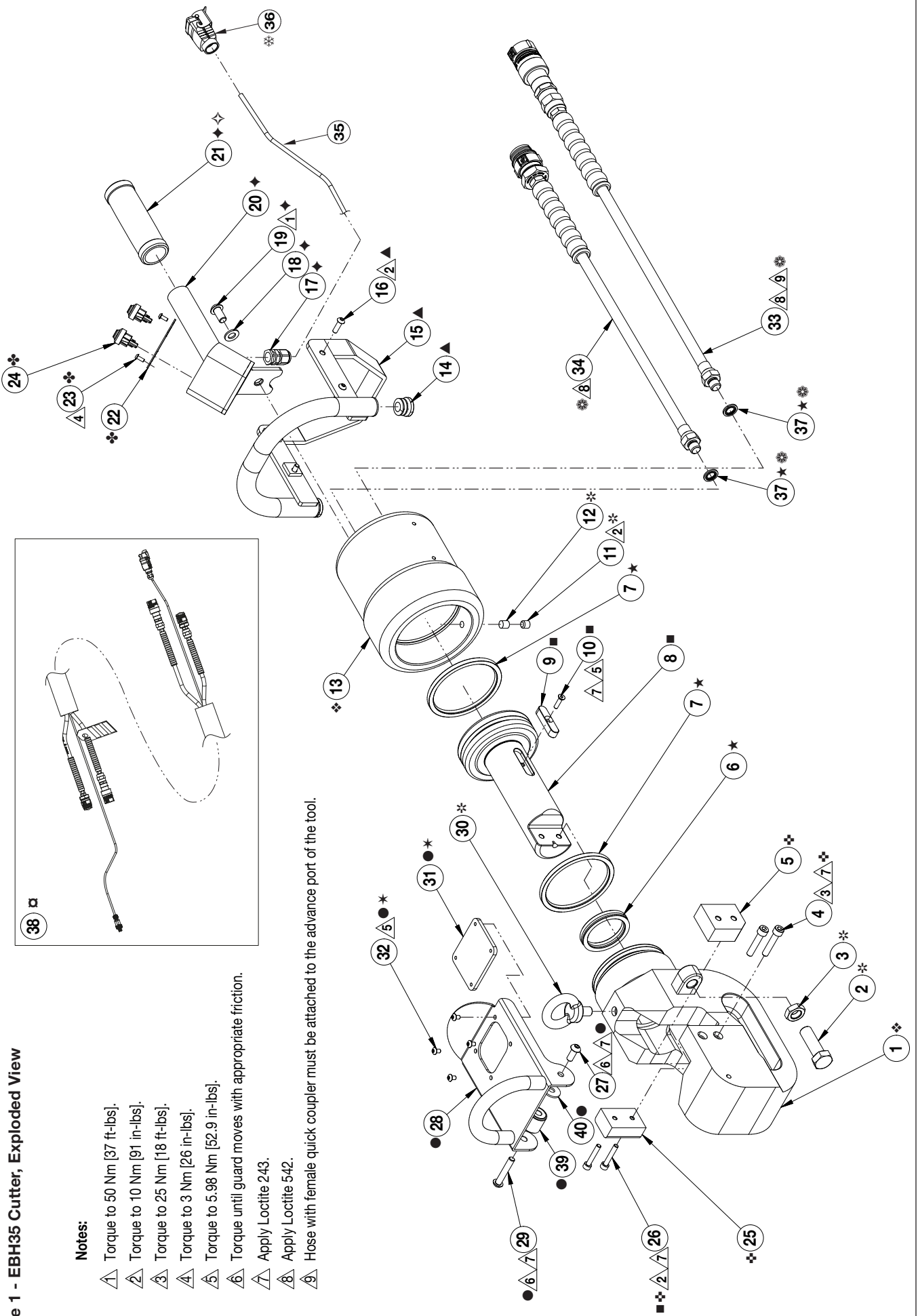

Repair Parts List for Figure 1			
Item No.	Part Number	Qty.	Description
1	❖	1	Head assembly
2	*	1	HXBT screw M16 x 50 UNI 5739 Zn
3	*	1	Nut M16 UNI 5589 Zn
4	❖	2	Socket cap screw M8 x 45 UNI 5931 Zn
5	❖	1	Fixed blade
6	★	1	Gasket CSC 6755
7	★	2	Gasket NPU 105 x 89.5 x 6.3
8	■	1	Piston
9	■	1	Key 12 x 10 x 50
10	■	1	Countersunk head screw M5 x 20 UNI 5933 Zn
11	*	1	Set screw M10 x 10 UNI 5923
12	*	1	Plastic pin
13	❖	1	Cylinder assembly
14	▲	2	Plastic plug
15	▲	1	Handle assembly
16	▲	4	Button screw M6 x 20 10.9 UNI 7380 Zn
17	◆	1	Cable gland
18	◆	1	Flat washer M10 UNI 6592 Zn
19	◆	1	Button screw M10 x 20 10.9 UNI 7380 Zn
20	◆	1	Handle assembly
21	◆	1	Grip
22	❖	1	Button panel
23	❖	2	Button screw M4 x 10 UNI 7380 Zn
24	❖	2	Push button switch
25	❖	1	Moving blade
26	❖	2	Socket cap screw M6 x 35 UNI 5931 Zn
27	●	1	Button screw M8 x 20 10.9 UNI 7380 Zn
28	●	1	Guard assembly
29	●	1	Button screw M8 x 45 UNI 7380 Zn
30	*	1	Eyebolt M12
31	● *	1	Transparent screen

Repair Parts List for Figure 1 (Continued)			
Item No.	Part Number	Qty.	Description
32	● *	4	Button screw M5 x 8 UNI 7380 Zn
33	⊗	1	High press. hose (700 Series) G 1/4 F + DC1392900
34	⊗	1	High press. hose (700 Series) G 1/4 F + C-J649096
35	N/A	1	Cable
36	⊗	1	Connector
37	★	2	Bonded seal washer (Included with items 33 and 34)
38	□	1	Hose and cable assembly, 6m long
39	●	1	Bushing for guard
40	●	1	Flat washer

Kit Information			
Symbol	Included In	See Figure	
❖	EBH3501K Blade Kit		2
★	EBH3502K Seal Kit		3
*	EBH3503K Small Parts Kit		4
▲	EBH3504K Lift Kit		5
◆	EBH3505K Head and Cylinder Body Kit		6
■	EBH3506K Piston Kit		7
●	EBH3507K Guard Kit		8
*	EBH3508K Guard Window Kit.		9
❖	EBH5204K Switches Kit		10
◆	EBH5205K Handle Kit		11
◇	EBH5206K Grip Kit		12
⊗	ECH500IK Hydraulic Hose Kit		13
*	CKECHYD Connector Kit		14
□	CH720EC Hose and Cable Assembly Kit		15
N/A	DKSCOMP Decal Kit		16

Refer to figures 2 through 16 for kit part exploded views and additional service information.

N/A - Not Available

Figure 2 - EBH3501K Blade Kit

Notes:

- ▲ 2 Torque to 10 Nm [91 in-lbs].
- ▲ 3 Torque to 25 Nm [18 ft-lbs].
- ▲ 7 Apply Loctite 243.

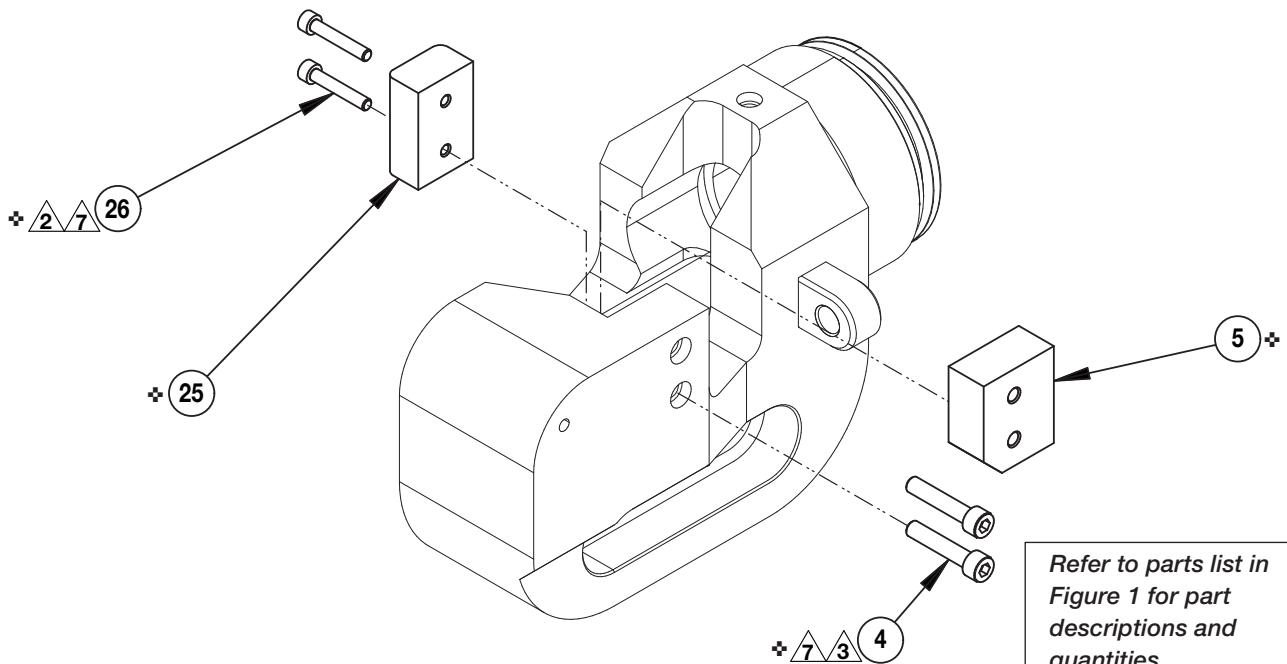

Refer to parts list in Figure 1 for part descriptions and quantities. (items marked “+”)

Figure 3 - EBH3502K Seal Kit

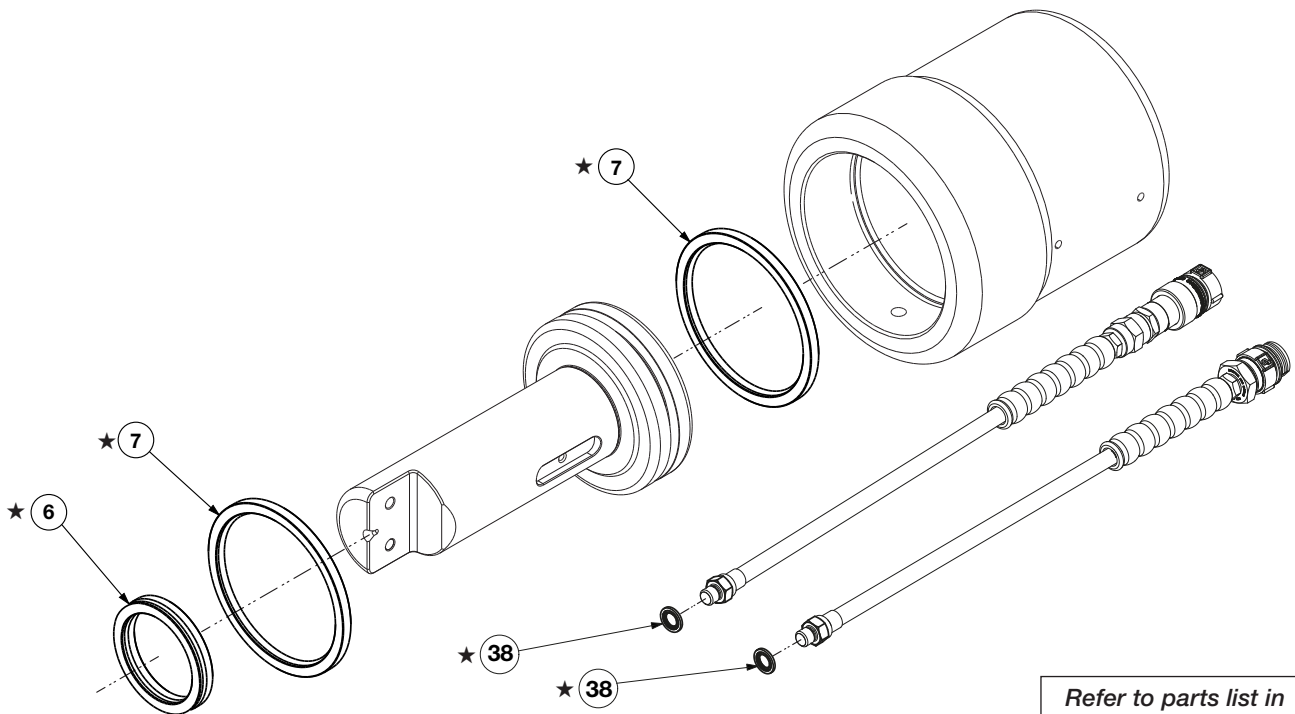

Refer to parts list in Figure 1 for part descriptions and quantities. (items marked “★”)

**Figure 4 - EBH3503K Small Parts Kit**

**Notes:**

 Torque to 10 Nm [91 in-lbs].

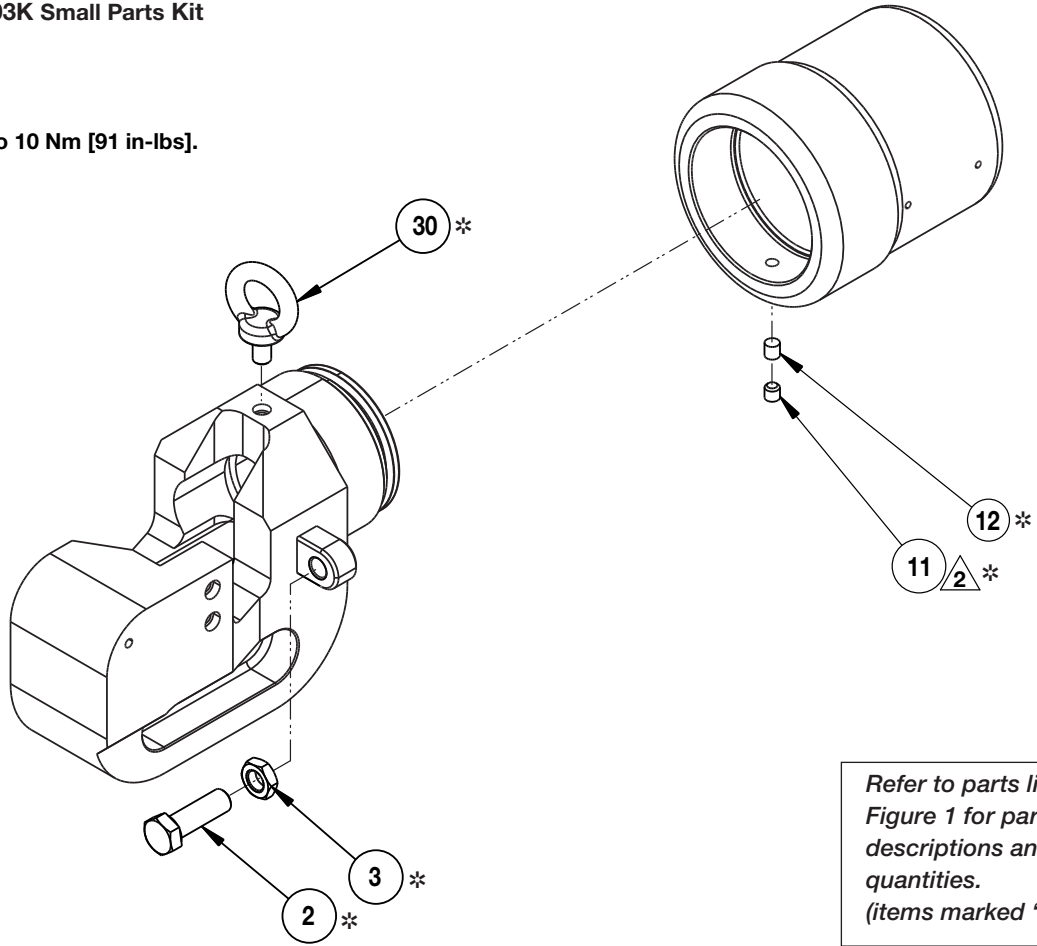

*Refer to parts list in Figure 1 for part descriptions and quantities. (items marked “\*”)*

**Figure 5 - EBH3504K Lift Kit**

**Note:**

 Torque to 3 Nm [26 in-lbs].

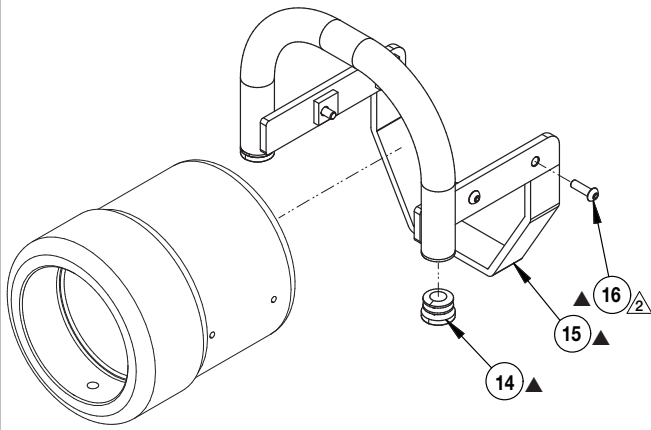

*Refer to parts list in Figure 1 for part descriptions and quantities. (items marked “▲”)*

**Figure 6 - EBH3505K Head & Cylinder Body Kit**

**Note:**

 Torque to 50 Nm [37 ft-lbs].

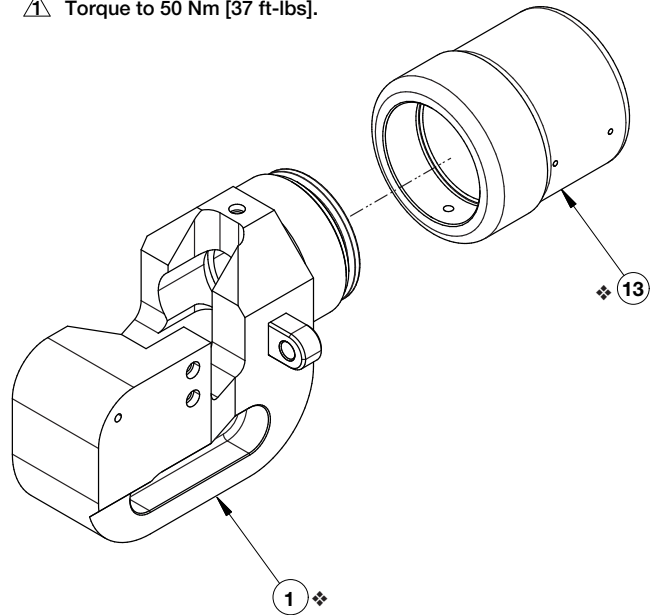

*Refer to parts list in Figure 1 for part descriptions and quantities. (items marked “◆”)*

Figure 7 - EBH3506K Piston Kit

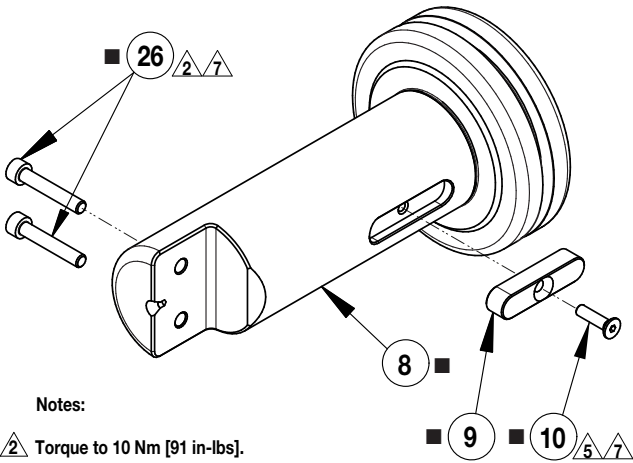

Notes:

- ▲ Torque to 10 Nm [91 in-lbs].
- ▲ Torque to 5.98 Nm [52.9 in-lbs].
- ▲ Apply Loctite 243.

Refer to parts list in Figure 1 for part descriptions and quantities. (items marked "■")

Figure 8 - EBH3507K Guard Kit

Notes:

- ▲ Torque to 5.98 Nm [52.9 in-lbs].
- ▲ Torque until guard moves with appropriate friction.
- ▲ Apply Loctite 243.

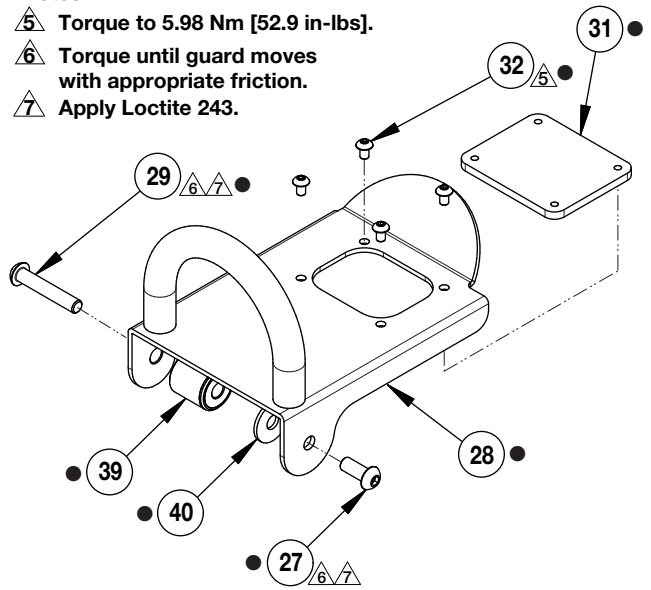

Refer to parts list in Figure 1 for part descriptions and quantities. (items marked "●")

Figure 9 - EBH3508K Guard Window Kit

Note:

- ▲ Torque to 5.98 Nm [52.9 in-lbs].

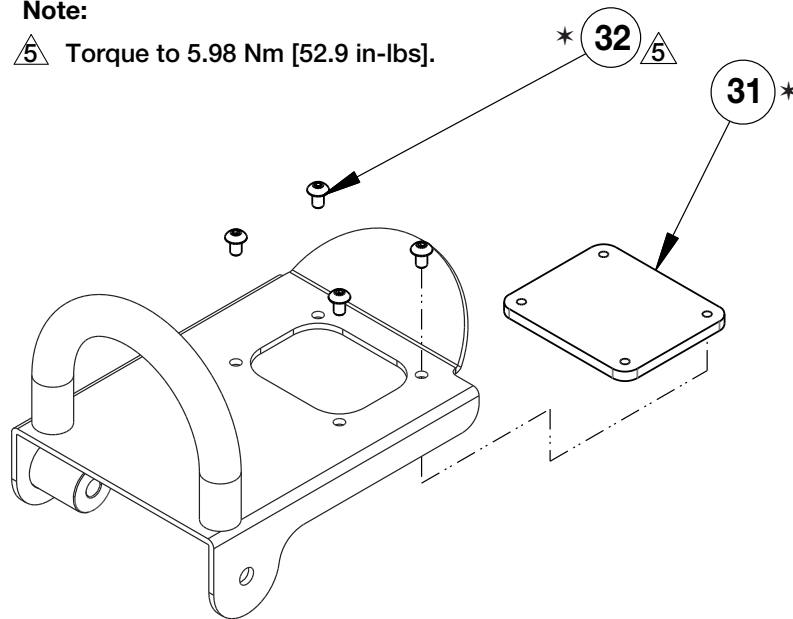

Refer to parts list in Figure 1 for part descriptions and quantities. (items marked "\*")

Figure 10 - EBH5204K Switches Kit

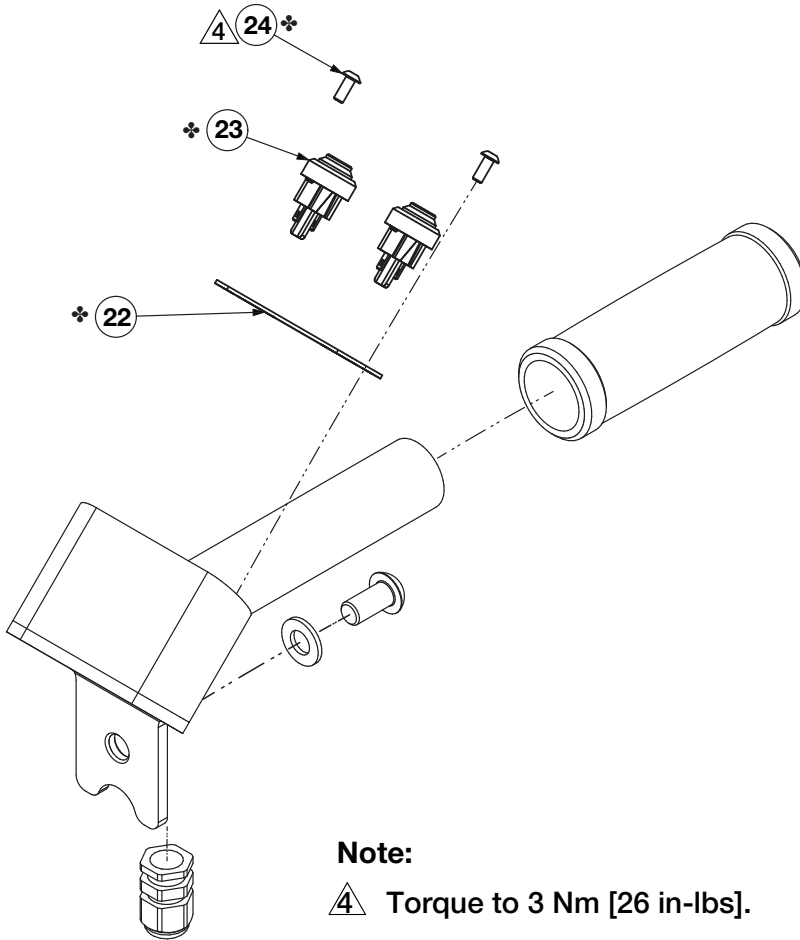

**Note:**  
▲ Torque to 3 Nm [26 in-lbs].

Refer to parts list in Figure 1 for part descriptions and quantities. (items marked "♣")

Figure 11 - EBH5205K Handle Kit

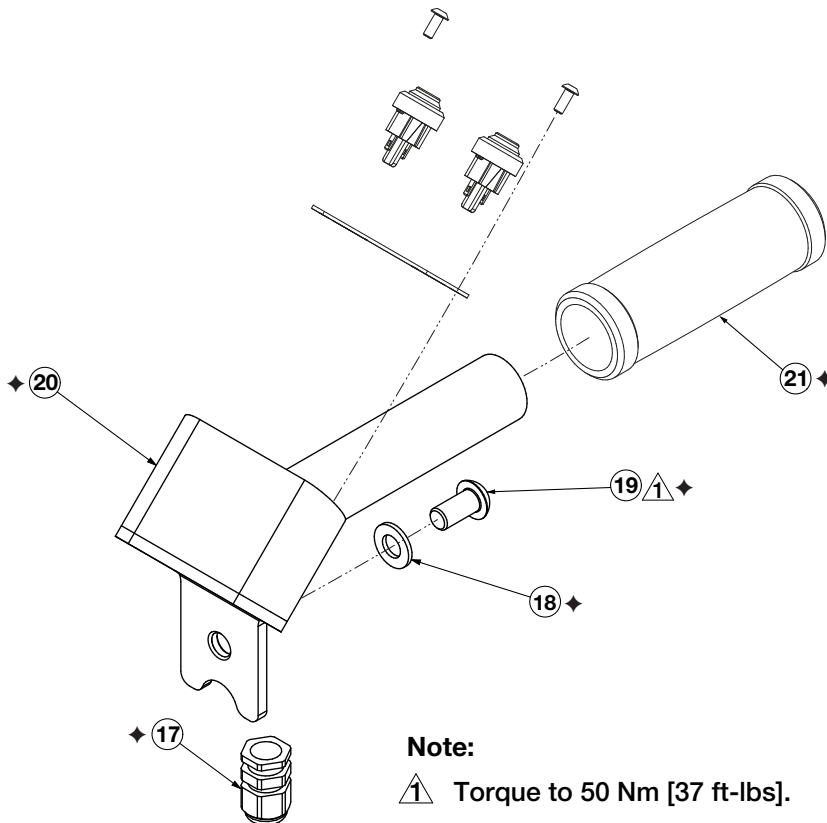

**Note:**  
▲ Torque to 50 Nm [37 ft-lbs].

Refer to parts list in Figure 1 for part descriptions and quantities. (items marked "◆")

Figure 12 - EBH5206K Grip Kit

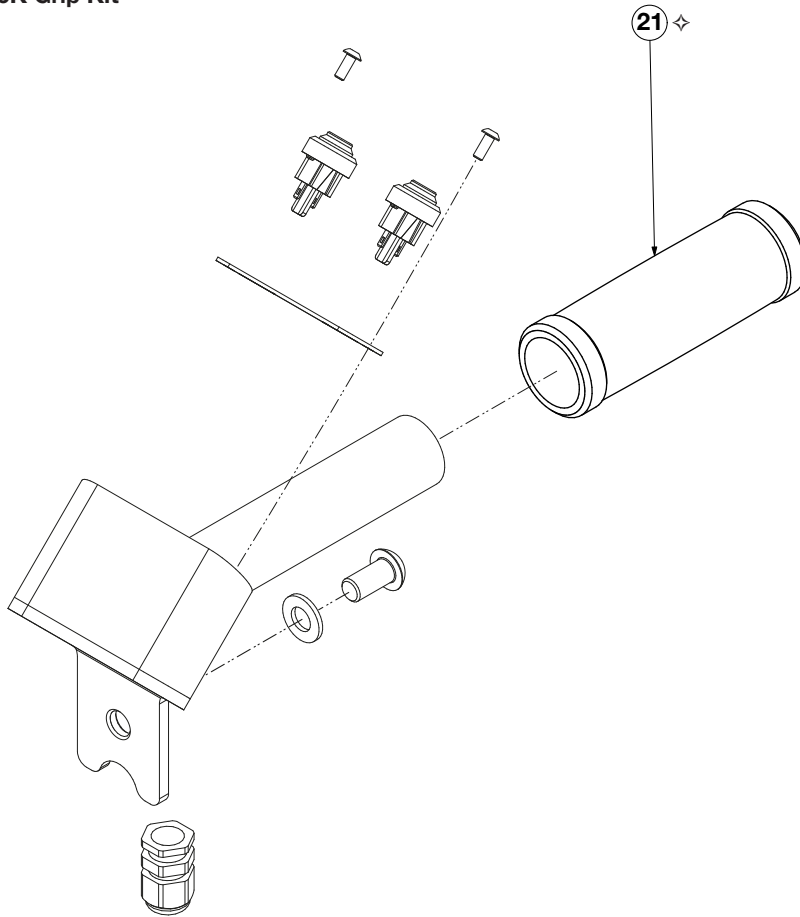

Refer to parts list in Figure 1 for part descriptions and quantities. (items marked "◇")

Figure 13 - ECH500IK Hydraulic Hose Kit.

**Notes:**

- △ 8 Apply Loctite 542.
- △ 9 Hose with female quick coupler must be attached to the advance port of the tool.

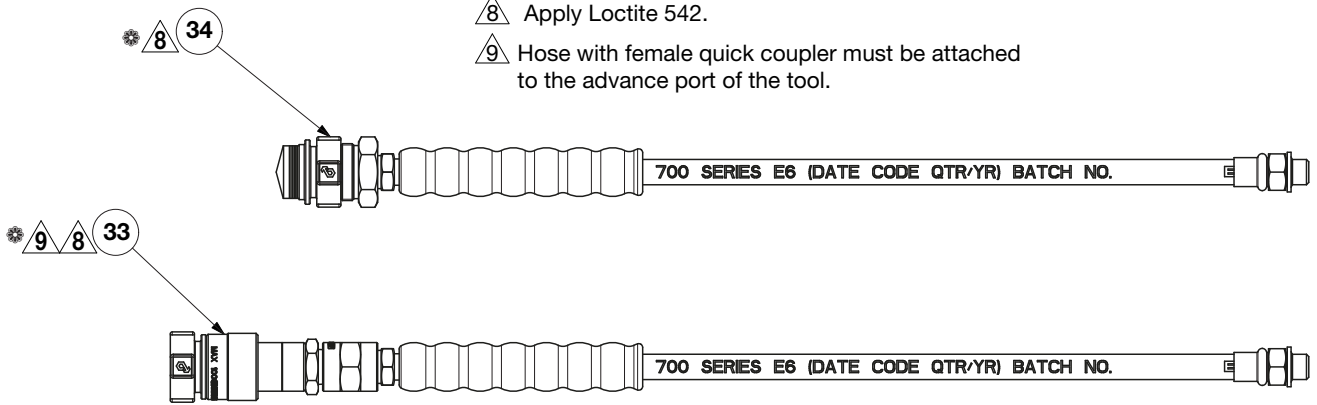

Refer to parts list in Figure 1 for part descriptions and quantities. (items marked "★")



Figure 14 - CKECHYD Connector Kit

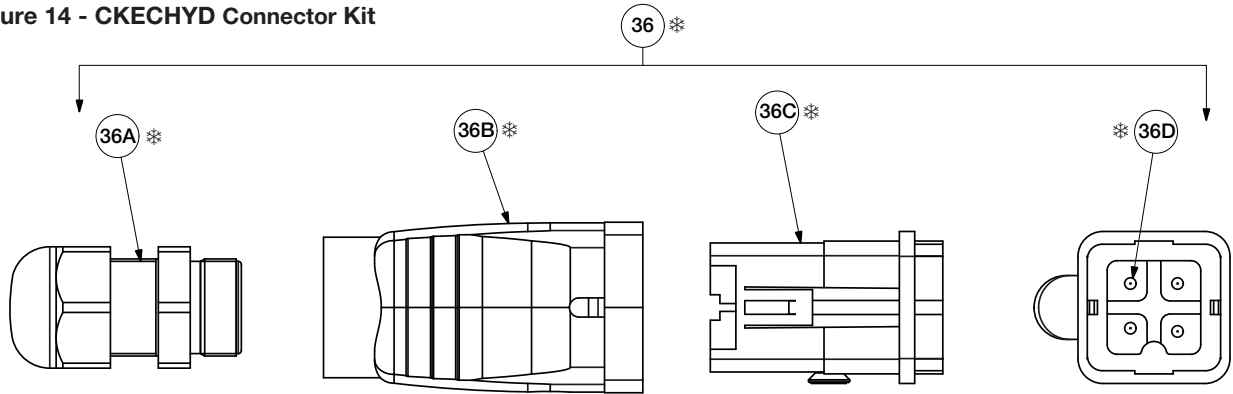

**Note:**

Items Included in the CKECHYD Kit (item 36):

Item No.	Description
36A	Cable Gland
36B	Housing
36C	Connector
36D	Pins

Figure 15 - CH720EC Hose and Cable Assembly Kit

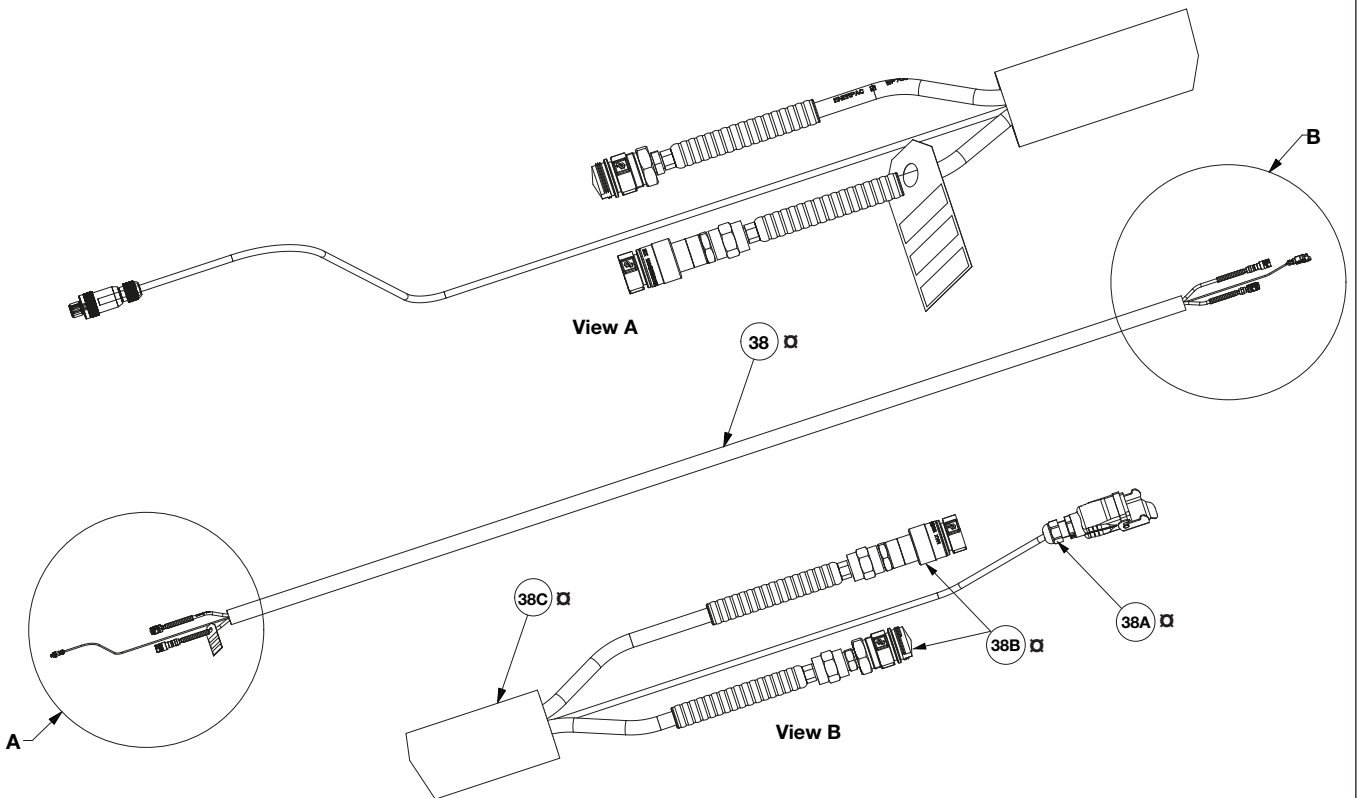

**Note:**

Items Included in the CH270EC Kit (item 38):

Item No.	Description	Part No.
38A	Electrical Cable	EW720EC
38B	Twin Hydraulic Hose Assy.	CH720MC
38C	Chafe Wrap	S720EC

**Notes:**

- The decal kit contains decals used on many different cutter models.
- Replace only the decals used on your cutter. Discard the remaining decals in the kit.



