



EQUALIZER[™]
AN ENERPAC BRAND

L4390

Rev. C

10/21

**FLANGE
SPREADING
WEDGE**
SWi5TE
SWi5TI

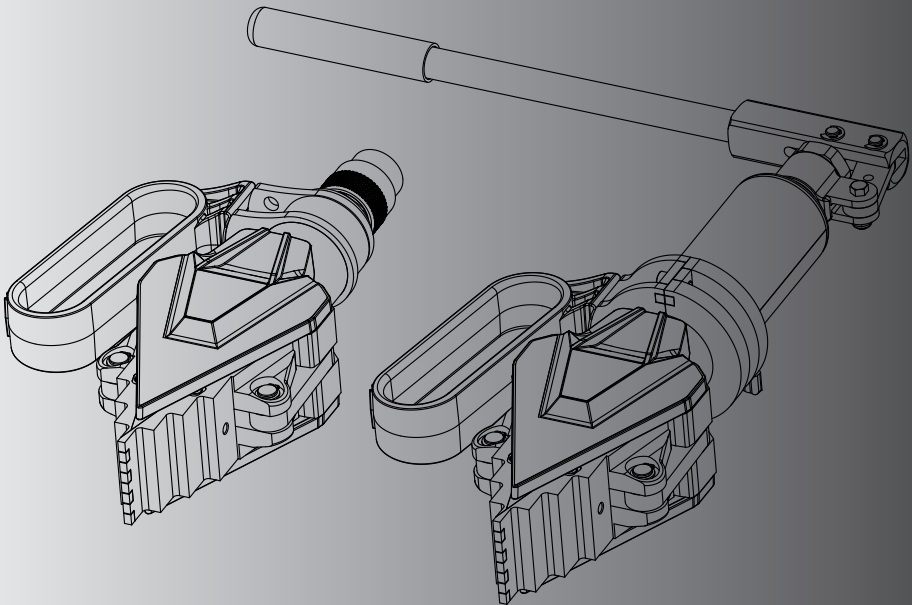

CONTENTS

1.0 INTRODUCTION	3
2.0 SAFETY	4
2.1 Safety Precautions - Flange Spreading Wedges.....	4
3.0 SWI SPREADING WEDGE TOOL OPERATION.....	6
3.1 General Guidance	6
3.2 Flange Spreading.....	6
3.3 Flange Work	7
3.4 Safety Blocks	7
3.5 Flange Closure	7
3.6 Stepped Blocks.....	7
3.7 Handle	8
3.8 Lanyard.....	8
4.0 TOOL MAINTENANCE	9
4.1 Inspection	9
4.2 Cleaning.....	9
4.3 Servicing.....	9
4.4 Lubrication Procedure	9
4.5 Storage & Transportation	9
4.6 Operating Conditions.....	9
4.7 Long-Term Storage - Maintenance Plan	10
4.8 Sub-Sea Usage	10
5.0 SWi5TE HYDRAULIC FLANGE SPREADING WEDGE	11
5.1 SWi5TE Tool Capabilities	11
5.2 SWi5TE Tool Function	11
5.3 SWi5TE Kit Contents	12
6.0 SWi5TI HYDRAULIC FLANGE SPREADING WEDGE.....	13
6.1 SWi5TI Tool Capabilities	13
6.2 SWi5TI Tool Function	13
6.3 SWi5TI Kit Contents.....	14
7.0 TROUBLESHOOTING	15
7.1 SWi5TE Troubleshooting	15
7.2 SWi5TI Troubleshooting.....	15
8.0 TECHNICAL DATA.....	17
8.1 SWi5TE/ SWi5TI Dimensions.....	17
8.2 Safety Block Dimensions.....	17
8.3 SWi5TI Handle Rod.....	17
8.4 SWi5TE/ SWi5TI Specification Table.....	18

For other languages go to www.equalizerinternational.com.

Weitere Sprachen finden Sie unter www.equalizerinternational.com.

Para otros idiomas visite www.equalizerinternational.com.

Pour toutes les autres langues, rendez-vous sur www.equalizerinternational.com.

その他の言語はwww.equalizerinternational.comでご覧いただけます。

이 지침 시트의 다른 언어 버전은 www.equalizerinternational.com.

Ga voor de overige talen naar www.equalizerinternational.com.

For alle andre språk henviser vi til www.equalizerinternational.com.

Inne wersje językowe można znaleźć na stronie www.equalizerinternational.com.

Информацию на других языках вы найдете на сайте www.equalizerinternational.com.

如需其他语言, 请前往 www.equalizerinternational.com.

1.0 Introduction

Overview

The Equalizer SWi5TE / SWi5TI has been developed to assist in the spreading of all flange joint types with a minimum access gap of 4.0 mm (0.16"). The tool can be used during pipework construction, commissioning or during routine maintenance.

The SWi tools have fewer moving parts and no finger pinch points. The tools have been developed to increase the spreading distance on each step while gaining easier access between any remaining stud-bolts within the flange joint. The SWi tools are supplied with a swivel handle and safety lanyard attachment as standard.

It is essential that the user familiarises themselves with the contents of this manual prior to using the tool.

Delivery Instructions

Upon delivery all components must be inspected for damage that incurred during shipping. If damage is found the carrier should be notified at once. Shipping damage is not covered by the Equalizer warranty.

Warranty

- Equalizer guarantees the product only for the purpose for which is intended.
- Refer to the Equalizer Global Warranty document for terms and conditions of the product warranty.

Any misuse or alteration invalidates the warranty.

- Observe all instructions as communicated in this manual.
- When replacement parts are needed, use only genuine Equalizer replacement parts.

Modification to any part of the equipment outlined in this manual should not be attempted, nor any component part be replaced without first consulting Equalizer. Modifications may render the equipment dangerous. Component parts are each rated to suit the demands of the overall equipment design and replacement with similar items without provenance may lead to unexpected and dangerous accidental features.

If any equipment abuse is evident, the warranty will be invalidated and Equalizer will not be made responsible for an injury due to misuse or failure to comply with the above safety notes.

Part Replacement

Check the Repair Parts Sheets (RPS), available at www.equalizerinternational.com, to order replacement parts when required.

Conformance to National and International Standards



Equalizer declares that the product(s) have been tested and conforms to applicable standards and the product(s) are compatible to all EU and UK Requirements.

Copies of the EU Declaration as well as the UK Self-Declaration are enclosed with each shipment.

2.0 Safety

Read all introductions carefully. Follow all recommended safety precautions to avoid personal injury as well as damage to the product and / or damage to other property. Equalizer cannot be responsible for any damage or injury from unsafe use, lack of maintenance, or incorrect operation. Do not remove warning labels, tags, or decals. In the event of any questions or concerns arising, contact Equalizer or a local Equalizer distributor for clarification.

If you have never been trained on high-pressure hydraulic safety, consult your distributor or service centre for information about Equalizer Hydraulic Safety Courses.

This manual follows a system of safety alert symbols, signals, words, and safety messages to warn the user of specific hazards. Failure to comply with these warnings could result in death or serious personal injury, as well as damage to the equipment or other property.



The Safety Alert Symbol appears throughout this manual. It is used to alert you to potential physical injury hazards. Pay close attention to Safety Alert Symbols and obey all safety messages that follow this symbol to avoid the possibility of death or serious injury.

Safety Alert Symbols are used in conjunction with certain Signal Words that call attention to safety messages or property damage messages and designate a degree or level of hazard seriousness. The Signal Words used in this manual are WARNING, CAUTION, and NOTICE.

⚠ DANGER Indicates a hazardous situation that, if not avoided, **will** result in death or serious personal injury.

⚠ WARNING Indicates a hazardous situation that, if not avoided, **could** result in death or serious personal injury.

⚠ CAUTION Indicates a hazardous situation that, if not avoided, **could** result in minor or moderate personal injury.

NOTICE Indicates information considered important, but not hazard related (e.g. messages related to property damage). Please note that Safety Alert Symbol will **not** be used with the signal word.



DO: an illustration showing how the tool should be used.



DON'T: an illustration showing an incorrect way to use a tool.

2.1 Safety Precautions - Flange Spreading Wedges

⚠ WARNING

Failure to observe and comply with the following precautions could result in death or serious personal injury. Property damage could also occur.

- Read and completely understand the safety precautions and instructions in this manual before operating the Flange Spreading Wedges or preparing them for use. Always follow all safety precautions and instructions, including those that are contained within the procedures of this manual.
- Ensure all hydraulic components are rated to a safe working pressure of 700 bar (10 000 psi).
- Do not overload equipment. The risk of hydraulic overloading can be minimised by using the Equalizer Hand Pump, which has a factory-set safety valve preventing the safe working pressure being exceeded.

If alternative hydraulic pumps are used, ensure that there are adequate systems to limit the working pressure to 700 bar (10 000 psi).

- Wear personal protective gear when operating hydraulic equipment. Always wear eye protection. Safety equipment such as dust mask, non-skid safety shoes, hard hats, gloves or hearing protection (used as appropriate) will reduce personal injuries.
- Applying pressure to a damaged hose may cause it to rupture.
- Immediately replace worn or damaged parts. Use only genuine Equalizer parts from approved distributors or service centres. Equalizer parts have been engineered and manufactured to be fit-for-purpose.
- To minimise risk of personal injury keep hands and feet away from the tool and workplace during operation.
- Do not handle pressurised hoses; escaping oil under pressure can penetrate the skin, causing serious injury. Seek medical attention immediately if oil penetration is suspected.
- Only pressurise complete and fully connected hydraulic systems. Do not pressurize systems that contain unconnected couplers.
- Care should be taken when using the lanyard to avoid entanglement with body parts.
- Take care to avoid sharp bends and kinks in hydraulic hoses. Bends and kinks can cause severe back-up pressure and cause hose failure. Protect hoses from dropped objects; a sharp impact may cause internal damage to hose wire strands. Protect hoses from crush risks, such as heavy objects or vehicles; crush damage can cause hose failure.
- Do not lift hydraulic equipment by the hoses or couplers. Use only the designated carrying handles.
- Lubricate tools as directed in this manual prior to operation. Use only approved lubricants of high quality, following the lubricant manufacturers instructions.
- Only use the designated anchor point for fixing the lanyard. Do not attach the lanyard to the plastic handle.

NOTICE

- Hydraulic equipment must only be serviced by a qualified hydraulic technician. For repair service, contact the Enerpac Authorized Service Centre in your area.
- Rope off working area and place warning signs.
- The vibration total value to which this tool is subjected does not exceed 2.5 m/s².

CAUTION

Failure to observe and comply with the following precautions could result in minor or moderate personal injury. Property damage could also occur.

- Ensure components are protected from external sources of damage, such as excessive heat, flame, moving machine parts, sharp edges and corrosive chemicals.

3.0 SWi Spreading Wedge Tool Operation

3.1 General Guidance

Before attaching the tool ensure at least two flange bolts remain in place. These should be 180 degrees apart with their nuts loosened sufficiently to enable flange work to be carried out. Leaving these bolts in place will help to reduce unwanted lateral flange movement during flange spreading (see fig.1).

Fig. 1



Prior to spreading, an assessment should be carried out to determine the most appropriate positioning of the tools around the joint. A minimum of 2 tools should always be used (see fig.2).

Fig. 2

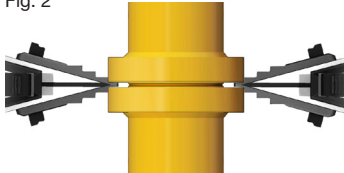

Determine the flange joint access gap - a minimum access gap of 4 mm (0.16") is required for the SWi5TE/SWi5TI tools. The access gap is the clearance between the surfaces onto which the wedge will apply its spreading force (see fig. 3).

Fig. 3

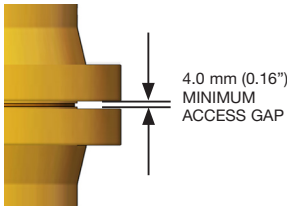

Place the tool into the access gap, with the full width of the selected step fully inserted up to the heel (see fig. 4).

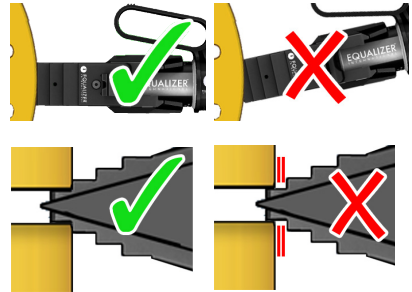

Fig. 4

3.2 Flange Spreading

Spread the flanges apart by actuating the tool.

Spread the flanges apart by actuating the tool. Consult the relevant sections of the manual for tool-specific instructions on how to activate each tool.

Once the joint has been opened to the desired distance, or if the tool has reached its maximum travel, insert the Safety Blocks into the flange joint (see fig. 5).

Fig. 5

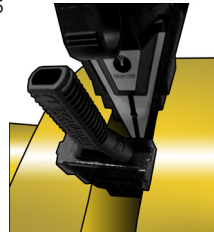

Ensure the full width of the selected Safety Block step is fully inserted before gradually retracting the tool until the flange load has been applied to the Safety Block (see fig. 6).

Fig. 6

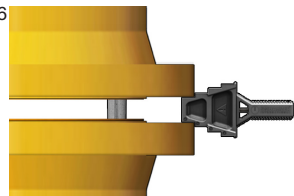

The wedges can then be retracted fully and inserted again, using the next step. In this way the flange joint can be iteratively opened further until the required spread is reached.

3.3 Flange Work

⚠ DANGER Do not rely upon hydraulic systems for supporting the access gap during flange work. Do not allow fingers, hands or other body parts into the space created between the flanges.

3.4 Safety Blocks

Each tool is supplied with a Safety Block. The Safety Block has been designed with steps that match the spreading distance of the SWi tools (see fig. 7).

Fig. 7



The Stepped Block Kit contains a larger Safety Block to cater for wider spreading distances.

3.5 Flange Closure

Allow the flanges to return to their closed position by gradually retracting the tool. Consult the relevant section of the manual for instructions on how to retract the tool. Before the tool has fully retracted, insert the Safety Blocks into the flange joint. Ensure the full breadth of the selected Safety Block step is fully inserted, before gradually retracting the tool until the flange load has been applied to them (see fig. 8).

Fig. 8

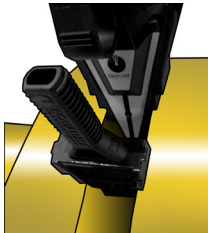

To use the smaller step of the safety block, place the tool in the gap and actuate enough to relieve the load on the Safety Blocks. In this way the flange joint can be progressively closed.

As the flange approaches its fully closed position, support the tool to avoid it dropping out of the joint. Ensure that care is taken to prevent objects being dropped. Dropped objects pose a risk of personal injury or equipment damage.

3.6 Stepped Blocks

A pair of Stepped Blocks can be supplied as a kit item. These can be fixed to the jaws (individually or in pairs) to increase the effective jaw thickness and therefore the maximum spreading distance.

Use of the Stepped Blocks also enables the SWi5TE/SWi5TI Flange Spreader to be used in a joint with a larger access gap.

Wedge protrusion can be minimised by the use of Stepped Blocks, reducing the penetration into the joint. This enables, for example, spectacle blinds to be changed.

Attach the stepped block to the tool using the M6 counter-sunk screw. Use the hex-key supplied to tighten the screw into the threaded hole in the jaw of the tool. Repeat for second Stepped Block to further increase the effective jaw thickness if required (see fig. 9).

Fig. 9

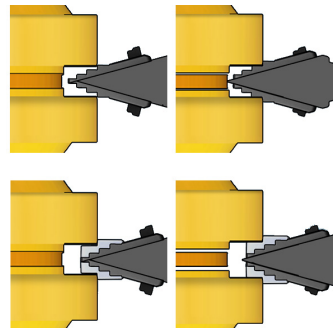

To remove the Stepped Blocks unscrew the M6 counter-sunk screw. Do not force the screw out of the Stepped Block, it is deliberately retained to prevent it becoming misplaced.

Use the tool as per the Tool Operation instructions. Ensure that there is a minimum hold of 15 mm (0.59") and that the full width of the block is used (see fig. 10).

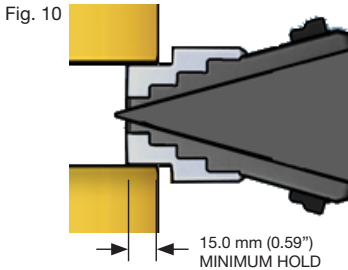

3.7 Handle

The handle can be swivelled around the central axis of the tool, to improve access to the Flange and allow the tool to be easily held in the vertical or horizontal orientation.

If the tool is being used in an application where access space is very limited, the handle can be removed temporarily.

SWi5TE - Remove circlip and handle (see fig. 11).

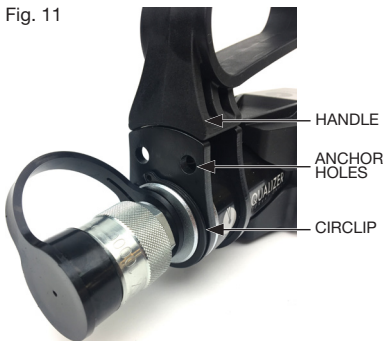

SWi5TE HANDLE/ CIRCLIP

SWi5TI - Remove two screws and handle (see fig. 12).

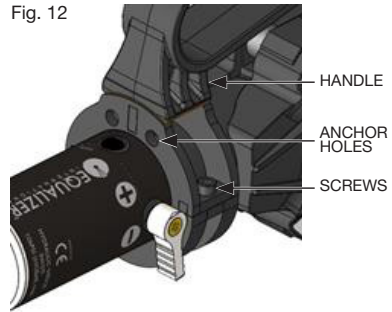

SWi5TI HANDLE/ SCREWS

Special caution should be exercised when working with a tool in this configuration. Replace the handle immediately following the task.

3.8 Lanyard

The SWi tools are supplied with a secure anchor point and a lanyard. The lanyard should be used to minimise the risks associated with the tool dropping.

Attach one end of the lanyard to the tool using the supplied shackle. The other end of the lanyard should be fixed to a secure point close to the work-site using an appropriate shackle.

Avoid using the lanyard as a means for picking up or carrying the tool.

The anchor point and lanyard have been engineered to safely sustain a drop over the full lanyard length. It is recommended that all parts are inspected following a drop incident, as damage may compromise the safety of the tool.

CAUTION Only use the designated handle anchor holes for fixing the lanyard (see fig 11 + 12).

DANGER Care should be taken when using the lanyard to avoid entanglement with body parts.

4.0 Tool Maintenance

4.1 Inspection

A thorough inspection should be carried out prior to usage, storage or transportation to ensure the completeness and condition of the tool.

Inspection should include:

- Visual inspection of the outer parts of the tool, checking for obvious damage, degradation or missing parts.
- Visual inspection of the wedge-tip (requiring tool actuation or jaw removal). Damage to the wedge-tip is indicative of tool over-load.

Cleaning and servicing should be undertaken as required prior to the tool being used, stored or transported.

4.2 Cleaning

To lightly clean the tool, wipe gently with a damp cloth.

If more thorough cleaning is required (for example following immersion in water) carry out the following cleaning procedure:

- Strip the tool down.
- Clean the components using detergent, following the manufacturer's guidelines.
- Rinse the components to remove traces of detergent.
- Dry the components thoroughly.

Inspect, service and lubricate the tool immediately after the cleaning process.

4.3 Servicing

Replace missing worn or damaged parts. Use only genuine Equalizer parts from approved distributors or service centres. Equalizer parts have been engineered and manufactured to be fit-for-purpose.

Grease all moving parts by following the Lubrication Procedure prior to usage, storage or transportation.

If topping up or replacing hydraulic oil as part of a service, use only premium quality hydraulic oil of the grade 15 cSt.

4.4 Lubrication Procedure

Apply grease following cleaning and servicing, prior to usage, storage or transportation. Never assemble and leave a tool without following the greasing procedure as degradation or damage may occur.

Use only high pressure molybdenum disulphide grease.

Remove the jaws as per the disassembly instructions.

Apply grease liberally to the following areas:

- The large flat surface on the underside of the jaws.
- The internal flat surfaces in the square cut-out in the jaws.

4.5 Storage & Transportation

Equalizer tools should be stored in a cool dry place. Tools should always be cleaned, serviced and lubricated prior to storage. Ensure that tools are stored in their designated packing cases.

4.6 Operating Conditions

GREASE LIMITATIONS:

Min Temperature: -5 °C (23 °F)

Max Temperature: 40 °C (104 °F)

MECHANICAL TOOLS:

Min Jaw Contact Temperature: -30 °C (-22 °F)

Max Jaw Contact Temperature: 150 °C (302 °F)

HYDRAULIC TOOLS:

Min Jaw Contact Temperature: -30 °C (-22 °F)

Max Jaw Contact Temperature: 70 °C (158 °F)

4.7 Long-Term Storage - Maintenance Plan

1. Rub components down with a dry cloth to remove moisture.
2. Coat EVERY surface and contact point with a corrosion inhibitor. Where necessary, coat inside and outside of component e.g. VC10
3. Nuts and threads must also be coated with a corrosion inhibitor.
4. Once surfaces have been coated, seal individual components in clear plastic bags or clear vacuum bags or clear shrink wrap. NOTE: bags/shrink wrap must be clear for visibility. Take care when using shrink wrap that the tool is / components are still easy to see.
5. Remove all or, where not vacuum sealed, as much air from bags as possible.
6. Once bags have been closed and sealed DO NOT re-open. Any visual inspections must be done with closed and sealed bags. If bags are opened the components will have to be dried, re-coated and re-sealed in bags/shrink wrap.
7. Replace silica gel (100g) EVERY TIME the case is opened.
NOTE: depending on moisture content of air, silica gel should be changed weekly.
8. Visually inspect kits after 30-days and every 30-days thereafter. Remember to replace silica gel before closing case.

4.8 Sub-Sea Usage

The Equalizer range of HP hydraulic hand pumps are fitted with a sealed-bladder type reservoir system that allows for sub-sea operation.

The SWi5TE is actuated by means of single-acting spring-return hydraulic cylinder and can be used sub-sea providing the following actions are taken:

1. The gauge and manifold are removed from the Equalizer HP350S/D hydraulic hand-pump and the coupler is fitted directly to the pump outlet (tools in this configuration can be requested from Equalizer).
2. The tool is connected to the Equalizer HP350S/D pump whilst still top-side.
3. The pump release valve is fully opened and remains open until the tool has descended to the working depth. This will allow the pressure to equalise.
4. The tool is actuated via the hand pump by a diver.
5. Upon completion of works the release valve is left in the fully-open position until the tool has ascended to the surface.
6. The tool and pump are stripped-down, cleaned and lubricated immediately to minimise corrosion.

Please note that a SWi5TE tool cannot be operated from top-side by use of a down-line. The return springs in the hydraulic cylinders do not have sufficient force to close the tool if used with a down-line from a top-side pump, therefore the standard hydraulic tools will not function correctly and may jam in place if used in this configuration.

5.0 SWi5TE Hydraulic Flange Spreading Wedge

The SWi5TE Spreading Wedge uses an external hydraulic pump to drive the cylinder to advance the wedge and spread the jaws.

Fig. 13

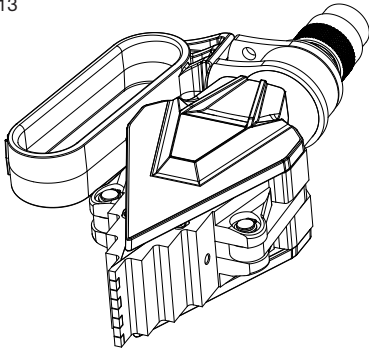

5.1 SWi5TE Tool Capabilities

Spreading Force

With 700 bar (10 000 psi) of hydraulic pressure applied, the tool can apply 6.3 T (63 kN) spreading force on the 1st step, up to 7.7 T (77 kN) spreading force on the 4th step.

Spreading Gap (See Section 3.9)

Using only the 1st step, the tool can spread from 4.0 mm to 29 mm (0.16" - 1.14").

Using all 4 steps, but without the stepped blocks, the tool can spread from 4 mm to 79 mm (0.16" - 3.1").

Using both steps on the stepped blocks, the tool can spread 56 mm – 101 mm (2.2" - 4").

5.2 SWi5TE Tool Function

Hydraulic Tool Operation

The SWi5TE Spreading Wedge uses a hydraulic cylinder to advance the wedge and spread the jaws. The hydraulic pressure is applied using an external hand pump, enabling accurate control of the force applied.

Hand Pump Operation

Consult the Instruction Manual for the Equalizer HP Hand-Pump.

Actuating The SWi5TE

Follow the SWi Spreading Wedge Tool Operation instructions, using the following instructions to actuate the SWi5TE tool in particular:

When the Hand-Pump release valve is closed, pumping the Hand-Pump handle will advance the cylinder and spread the jaws.

When using multiple tools, ensure that the spread of all tools correspond to keep the spreading force balanced.

Equalizer manufactures a twin-port hand pump which can be used to actuate two tools simultaneously.

Retracting The SWi5TE

Opening the release valve will depressurise the cylinder and cause it to retract under the force of its internal spring. The handle does not need to be pumped to retract the tool.

When using multiple tools, exercise caution while retracting to keep the spreading force balanced as the gap is closed.

Air-Lock Relief

If full pressure is not achieved an air-lock may be present in the hydraulic system. The following procedure can be executed to relieve any air-locks.

Connect the hand pump to the tool with the hydraulic hose. Close the release valve on the pump, and prime the pump until the hydraulic cylinder is fully extended and a small pressure is achieved.

With the hand pump elevated above the level of the tool, and the tool in an upright position, open the hand pump release valve causing any air that is within the system to be forced up through the pump and vented into the oil reservoir.

Repeat this process three further times to ensure that all air is removed from the system. The tool should now reach full working pressure.

Disconnect the hand pump from the hydraulic hose, grip the baseplate of the hand pump body in a vice with the pump body vertical and the main handle at the top. Remove the four nuts holding the main handle and lift off. Grip the refilling plug with pliers and extract it by pulling and twisting simultaneously. Ensure the reservoir body is held down when removing the refilling plug as pulling up on the reservoir body will release the bladder within, and oil may spill out. Fill the reservoir to the top with a premium quality hydraulic oil of the grade 15 cSt. Reinsert the refilling plug, wipe away any oil, and reassemble by reversing the disassembly process.

5.3 SWi5TE Kit Contents

Single Kit (see fig. 14)

- Product Code: SWi5TE-S
- 1 x SWi5TE Flange Spreading Tool
- 1 x Safety Block
- 1 x Lanyard
- 1 x Moulded Plastic Carry Case with Protective Foam Insert



Fig. 14

Twin Kit (see fig. 15)

- Product Code: SWi5TE-T
- 2 x SWi5TE Flange Spreading Tool
- 2 x Sets of Standard Safety Blocks
- 2 x Lanyards
- 1 x Moulded Plastic Carry Case with Protective Foam Insert



Fig. 15

Stepped Block Kit (see fig. 16)

- Product Code: 1640016-01
- 1 x Pair of SWi5TE Step Block
- 2 x M6 CSK Hex Screw
- 2 x Retaining Washer
- 1 x SWi5TE Large Safety Block
- 1 x Hex Key

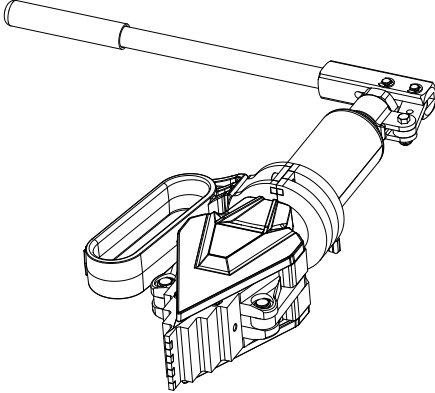

Fig. 16

6.0 SWi5TI Hydraulic Flange Spreading Wedge

The SWi5TI Spreading Wedge uses an integral hydraulic pump to drive the cylinder to advance the wedge and spread the jaws.

Fig. 17



6.1 SWi5TI Tool Capabilities

Spreading Force

With 700 bar (10 000 psi) of hydraulic pressure applied, the tool can apply 6.3 T (63 kN) spreading force on the 1st step, up to 7.7 T (77 kN) spreading force on the 4th step.

Spreading Gap (See Section 3.9)

Using only the 1st step, the tool can spread from 4.0 mm to 29 mm (0.16" - 1.14").

Using all 4 steps, but without the stepped blocks, the tool can spread from 4 mm to 79 mm (0.16" - 3.1").

Using both steps on the stepped blocks, the tool can spread 56 mm – 101 mm (2.2" - 4").

6.2 SWi5TI Tool Function

Hydraulic Tool Operation

The SWi5TI Spreading Wedge uses a hydraulic cylinder to advance the wedge and spread the jaws. The hydraulic pressure is applied using an integral hand pump, enabling accurate control of the force applied.

Actuating The SWi5TI

Follow the SWi Spreading Wedge Tool Operation instructions, using the following instructions to actuate the SWi5TI tool in particular:

When the Hand-Pump release valve is closed, pumping the Hand-Pump handle will advance the cylinder and spread the jaws.

When using multiple tools, ensure that the spread of all tools correspond to keep the spreading force balanced.

Retracting The SWi5TI

Opening the release valve will depressurise the cylinder and cause it to retract under the force of its internal spring. The handle does not need to be pumped to retract the tool.

When using multiple tools, exercise caution while retracting to keep the spreading force balanced as the gap is closed.

Air-Lock Relief

If full pressure is not achieved an air-lock may be present in the hydraulic system. The following procedure can be executed to relieve any air-locks.

Select advance, and pump the handle to extend the piston around 30mm (1.2"). Remove the Oil Fill Screw using an appropriate hex key, ensuring the tool is on its side with the Oil Fill facing upwards (fig. 18).

Replenish any missing hydraulic oil by pouring into the Oil Fill hole until excess spills over (fig.19 / fig.20).

Sit the tool with the wedge facing uphill (and the open Oil Fill hole still facing upwards) on a gentle slope, around 30 degrees from horizontal.

Very slowly move the selector from advance to retract, and wait for the tool to fully retract (fig.21/ fig.22 / fig.23).

Replace the Oil Fill Screw.

Repeat this procedure 3 times.

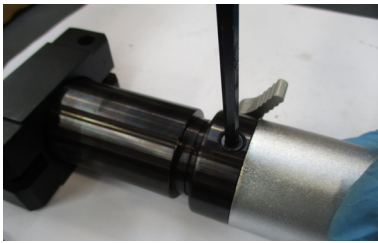

Fig. 18

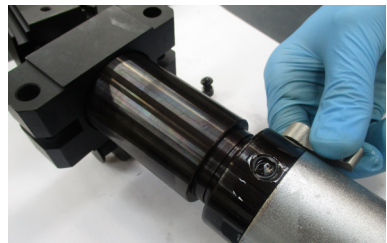

Fig. 21



Fig. 19

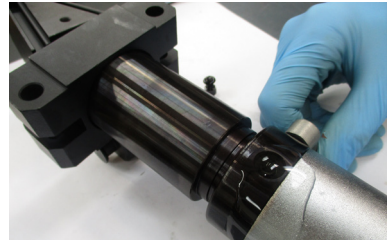

Fig. 22



Fig. 20

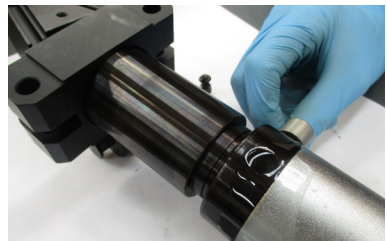

Fig. 23

6.3 SWi5TI Kit Contents

Single Kit (see fig. 24)

Product Code: SWi5TI-S

1 x SWi5TI Flange Spreader Wedgehead

1 x Standard Safety Block

1 x Lanyard

1 x Moulded Plastic Carry Case with
Protective Foam Insert



Fig. 24

Stepped Block Kit (see fig. 25)

Product Code: 1640016-01

1 x Pair of SWi5TE Stepped Block

2 x M6 CSK Hex Screw

2 x Retaining Washer

1 x SWi5TE Large Safety Block

1 x Hex Key



Fig. 25

7.0 Troubleshooting

7.1 SWi5TE Troubleshooting

The wedge is advancing but does not reach full pressure.

Possible Cause:

There is air in the hydraulic system.

Recommended Action:

Follow the Airlock Relief instructions.

7.2 SWi5TI Troubleshooting

The wedge is advancing but does not reach full pressure.

Possible Cause:

There is air in the hydraulic system.

Recommended Action:

Follow the Airlock Relief instructions.

The wedge advances some of the way and then stops progressing

Possible Cause:

The air-vent is obstructed by dirt or debris.

Recommended Action:

Place the valve in the retract position and prime pump to circulate oil around the system

The wedge doesn't move.

Possible Cause:

There is an air-lock within the hydraulic system.

Recommended Action:

Select Retract and prime to circulate oil around the system.

Possible Cause:

Insufficient oil in the hydraulic system.

Recommended Action:

Refill with clean oil and bleed the hydraulic system.

Possible Cause:

Retract is selected.

Recommended Action:

Select Advance and pump the handle.

Possible Cause:

Air has accumulated around pump inlet when used upside down.

Recommended Action:

Bleed any air from the hydraulic reservoir. Inspect the tool for oil leaks on the reservoir, possibly indicative of a perished bladder. Refer to an approved Equalizer distributor for repair.

Possible Cause:

The inlet check-valve or intermediate valve ball has become stuck.

Recommended Action:

Dismantle the check valve, free and clean the valve balls. Refer to an approved Equalizer distributor for repair.

The wedge moves as intended, but doesn't seem to be achieving full pressure when under load.

Possible Cause:

Intermediate valve not seating / relief valve leaking.

Recommended Action:

Check cleanliness of the valve ball. Re-seat using a hammer and punch. Refer to an approved Equalizer distributor for repair.

Hydraulic pressure slowly diminishes and the pump handle rises.

Possible Cause:

The outlet check valve is leaking.

Recommended Action:

Check cleanliness of the valve ball. Re-seat using a hammer and punch. Refer to an approved Equalizer distributor for repair.

Hydraulic pressure slowly diminishes and the pump handle does not rise.

Possible Cause:

The release valve is leaking.

Recommended Action:

Refer to an approved Equalizer distributor for repair.

Possible Cause:

The piston seal is leaking.

Recommended Action:

Inspect the tool for oil leaks, possibly indicative of a perished seal or loose blanking plug. Refer to an approved Equalizer distributor for repair.

Tool actuation feels soft and unresponsive.

Possible Cause:

There is air in the hydraulic system.

Recommended Action:

Bleed the hydraulic system. Refer to an approved Equalizer distributor for repair.

8.0 Technical Data

8.1 SWi5TE/ SWi5TI Dimensions (see fig. 26)

Fig. 26

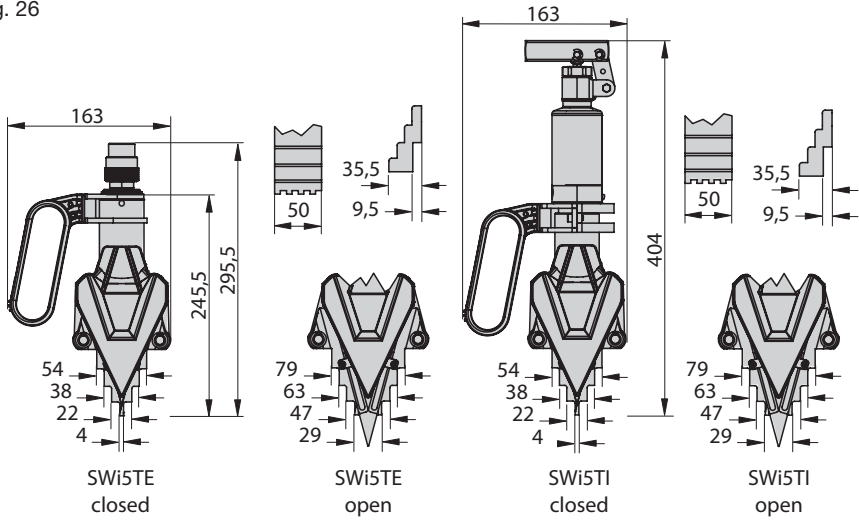

8.2 Safety Block Dimensions (see fig. 27)

Fig. 27

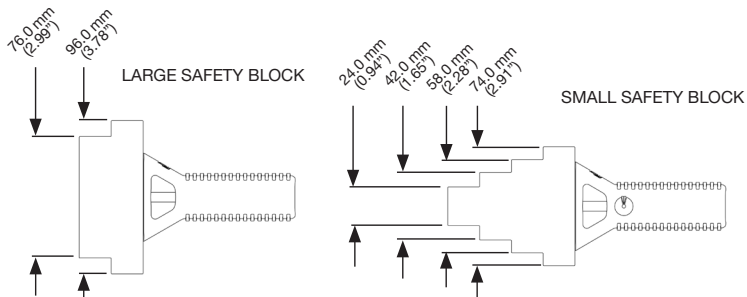

8.3 SWi5TI Handle Rod (see fig. 28)

Fig. 28

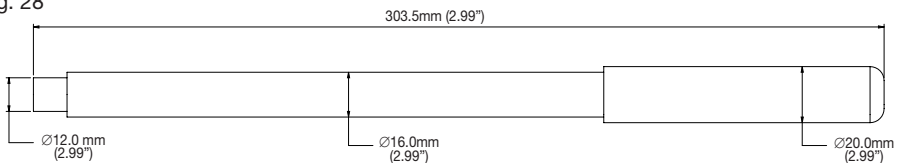

8.4 SWi5TE/ SWi5TI Specification Table

Model Number	Type	Maximum Spreading Force Per Tool (US tons)	Spreading Distance Maximum (in)	Flange Dimensions	Jaw Width (in)	Tool Weight (lbs)	Kit Weight (lbs)	Case Dimensions (in)
				Minimum Access Gap A (in)				
SWi5TE-S*	External Hydraulic	8.65 (77 kN)	4 (102 mm)	0.16 (4 mm)	1.97 (50 mm)	11.4 (5.17 kg)	19.1 (8.66 kg)	22.8 x 13.4 x 7.1 (579 x 340 x 180 mm)
SWi5TE-T*	External Hydraulic	8.65 (77 kN)	4 (102 mm)	0.16 (4 mm)	1.97 (50 mm)	11.4 (5.17 kg)	31.7 (14.38 kg)	22.8 x 13.4 x 7.1 (579 x 340 x 180 mm)
SWi5TI-S*	Integral Hydraulic	8.65 (77 kN)	4 (102 mm)	0.16 (4 mm)	1.97 (50 mm)	15.4 (6.99 kg)	23.1 (10.48 kg)	22.8 x 13.4 x 7.1 (579 x 340 x 180 mm)
* Tool Number: SWi5TE				• Tool Number: SWi5TI				

