

ENERPAC

A UNIT OF APPLIED POWER INC. 

Repair Parts Sheet

RRH-1001

L-575
REV A
3-91

SERIAL NUMBERS BEGINNING WITH "A"

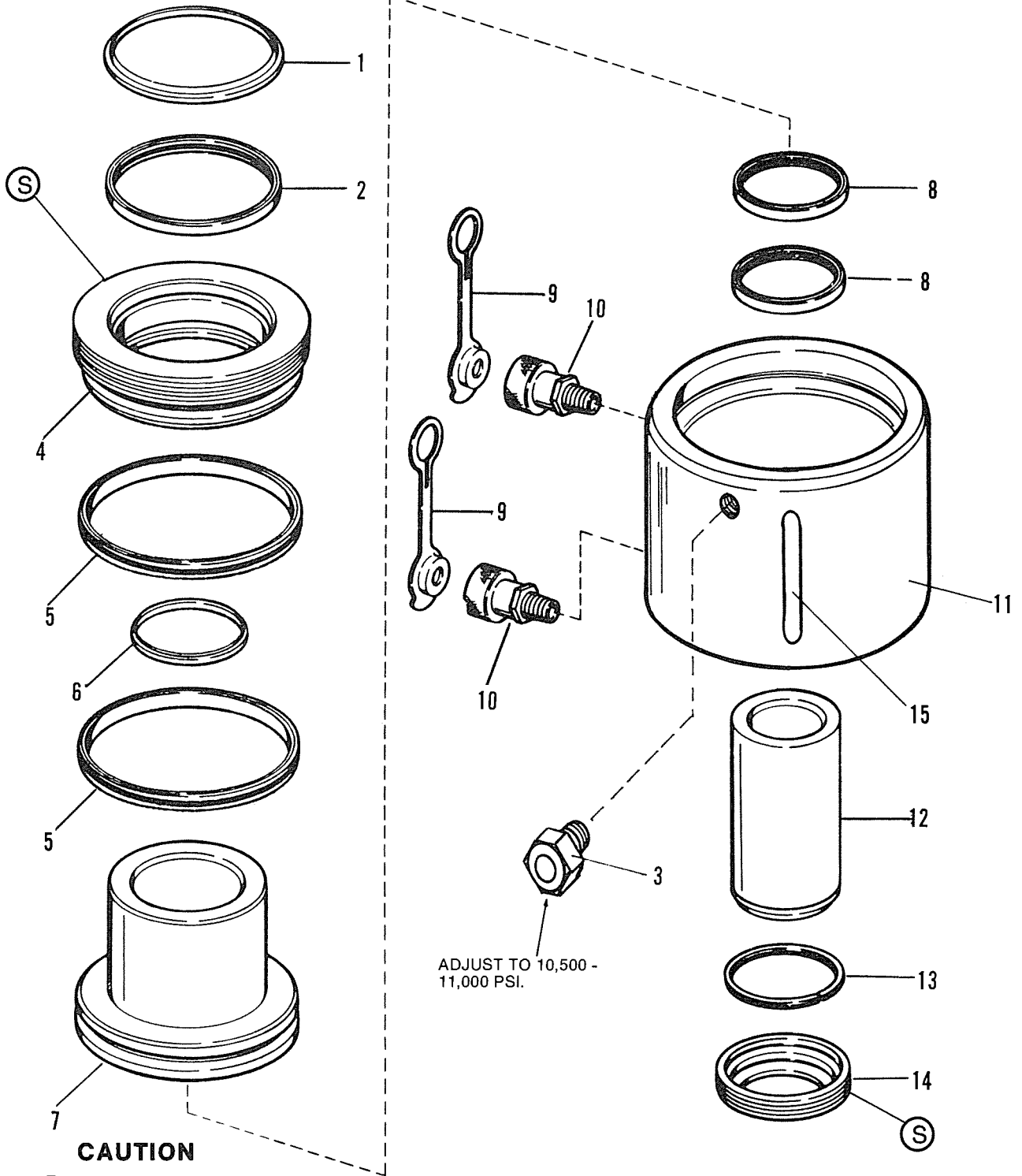

CAUTION

(S) INDICATES STAKED THREADS.
REMOVE STAKE MARK PRIOR TO REMOVAL OF THIS PART.
FAILURE TO DO SO MAY RESULT IN DAMAGE TO THE PART DURING REMOVAL.
RE-STAKE AFTER REPAIRED CYLINDER HAS BEEN TESTED.

TO PROTECT YOUR WARRANTY, USE ONLY ENERPAC HYDRAULIC OIL.

PARTS LIST

Item No.	Part Number	No. Req'd.	Description
1	* F549.044	1	Ring, Wiper
2	* B1337.514	2	Ring, G-T Assembly
3	CJ160.900	1	Valve Assy, Relief
4	CL824.044	1	Ring, Stop
5	* B1349.514	1	Ring, G-T Assembly
6	* F555.044	1	Wiper
7	Y89.040	1	Plunger
8	* B1435.513	2	Ring, G-T Assembly
9	CD-411	2	Cap, Dust
10	CR-400	1	Coupler, Half
11	CL823.030	1	Cylinder
12	Y232.013	1	Guide, Plunger
13	Y416.044	1	Ring, Retaining
14	Y254.044	1	Ring, Stop
15	CM584.070	1	Handle

*Indicates items included in and available only as part of Repair Kit RRH-1001K.

For Viton Seals order RRH-1001KV in place of the standard Repair Kit RRH-1001K.

Australia
29-31 O'Riordon Street
Alexandria, N.S.W. 2015
Tel: (61) (2) 698-9955
Fax: (61) (2) 698-9664

Canada
6490 Vipond Drive
Mississauga, Ontario
L5T 1W8 Canada
Tel: (416) 564-5749
Fax: (416) 564-0305
Telex: 06-968544
1-800-268-6975
In Quebec or Ontario
1-800-268-4987

**Eastern Europe and
Other European Countries,
Middle East and Africa**
47, avenue Blanc
P.O. Box 67 1211
Geneva 21, Switzerland
Tel: (41) 731 94 05
Telex: 41 2843
Fax: (41) 731 12 15

Far East
47 Jalan Pemimpin,
#01-02 & 01-03
Sin Cheong Building
Singapore 2057
Thomson Road P.O. Box 114
Singapore 9157
Tel: (65) 2581677
Telex: RS 24882 APOWR
Fax: (65) 2582847

France
B.P. 200
Parc d'Activités du Moulin
de Massy
91882 Massy Cedex
Tel: (331) 69 20 70 70
Telex: 60 09 51
Fax: (331) 69 20 37 50

Italy
Via Canova, 4
20094 Corsico
Milano, Italy
Tel: 02/458 2741
Telex: 352337
Fax: 39-2-48601288

Japan
10-17 Sasame
Kita-Cho, Toda-Shi
Saitama 335,
Japan
Tel: 0484-22-2251
(Administration Dept.)
0484-21-2311 (Sales Dept.)
Telex: 26275
Fax: 0484-22-0596

**Latin America
and Caribbean**
13000 West Silver Spring Drive
Butler, Wisconsin 53007
Tel: (800) 558-0530
Fax: (414) 781-1049

Mexico
Blvd. Gral. Felipe Angeles 1604
P.Q. Box 362
42080 Pachuca. Hidalgo
Mexico
Tel: (52) (771) 3-37-00 or
(52) (771) 8-38-00
Telex: 17 55 15
Fax: (52) (771) 3-11-96 or
(52) (771) 3-52-32

**Netherlands, Belgium,
Luxemburg**
Storkstraat 25/P.O. Box 269
NL-3900 AG Veenendaal
Tel: (31) (8385) 35911
Telex: 35381
Fax: (31) (8385) 25613/26645

South Korea
163-12, Dodang-Dong,
Choong-Ku,
Buchun-Shi, Kyunggi-Do
Republic of Korea
Tel: (82) (32) 6560836/7
Fax: (82) (32) 6563002

Spain
Applied Power International, S.A.
C/La Granja, s/n
Poligono Industrial
281 00 Alcobendas (Madrid)
Spain
Tel: (34) (91) 6523633
Telex: 22826
Fax: (34) (91) 6543927

United Kingdom
Leacon Road
Ashford, Kent
TN23 2TU
England
Tel: (44233) 639871
Telex: 96 64 50
Fax: (44233) 643923

United States
13000 West Silver Spring Drive
Butler, Wisconsin 53007
Tel: (800) 558-0530
Fax: (414) 781-1049

West Germany
Applied Power GmbH
Mündelheimer Weg 51
P.O. Box 300 113
D-4000 Düsseldorf 30
Tel: (49) (211) 41707-0
Telex: 8582790
Fax: (49) (211) 4170740

REPAIR AND SERVICE INFORMATION: For repair service and parts contact your nearest authorized ENERPAC Technical Service Center. The Authorized Enerpac Technical Service Center will provide complete and prompt service on all Enerpac products. For the location of an ENERPAC Service Center, call **Toll Free 1-800-558-0530. (In Canada CALL 1-800-268-6975)**

NOTE: This phone number is not for product repair information.

WARRANTY INFORMATION: All warranty repairs must be performed by an authorized Enerpac Technical Service Center. All Enerpac tools are guaranteed from date of delivery to user against defects in workmanship and materials. Free repair or replacement will be made on all items not standing up to this guarantee. Following manufacturers trade custom, however, chains cannot be guaranteed. Warranty does not cover ordinary wear and tear, abuse or misuse, overloading, altered products or use of improper fluids. For prompt handling, send items requiring repairs prepaid, to your nearest authorized Enerpac Technical Service Center. Warranty repair service for non-Enerpac components used on Enerpac products, should be obtained through an authorized Service Center representing the manufacturer of the item.