

Document Number	Revision	Revision Date	Product Code Beginning With
L629	Rev. G	02/2021	O - JHA156 A - JHA356

**Ⓢ CAUTION:** Indicates staked threads. Stake mark must be removed prior to disassembly. Failure to do so may result in damage to parts.

Some cylinder stop rings are assembled with Loctite material on threads. Enerpac suggests staking threads when reassembling.

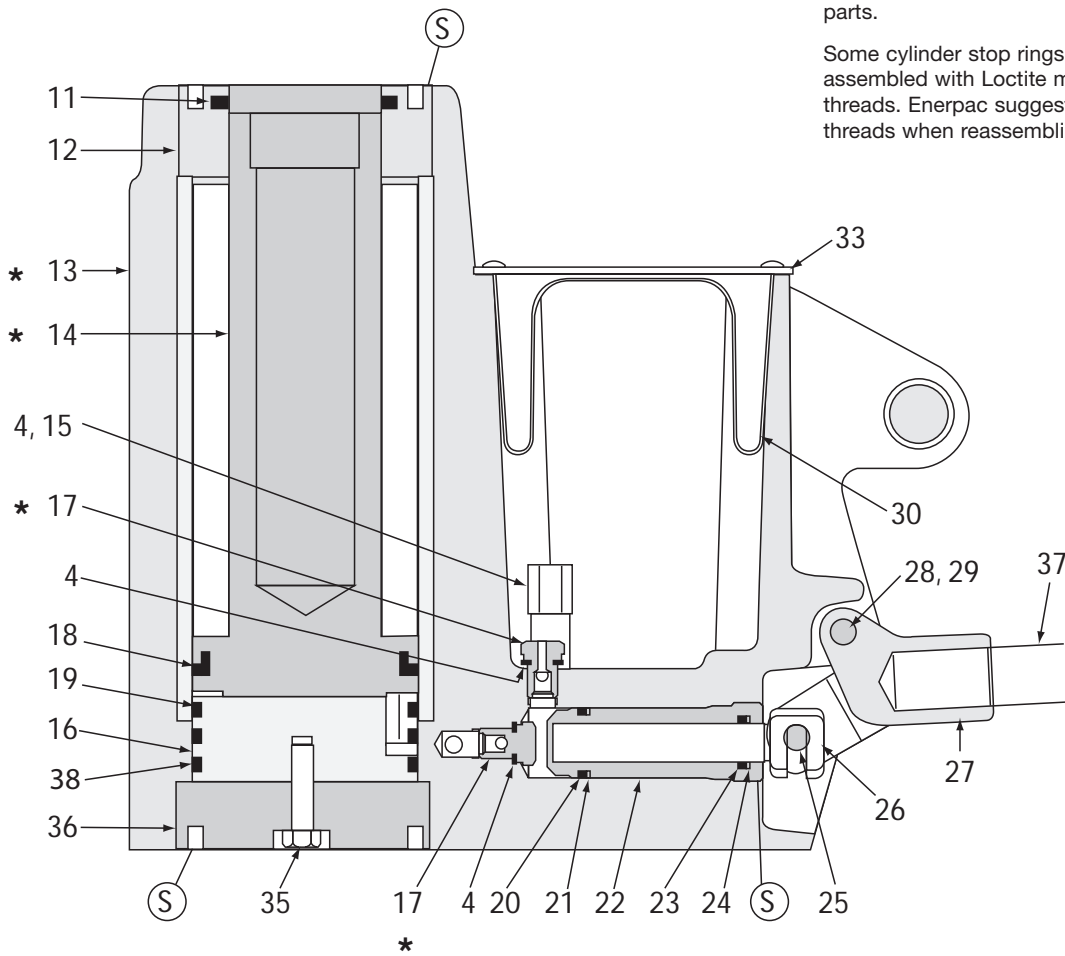

Figure 1



**Note: See Page 2 for parts list.**

(*) Notes	
13	Not available as a service item. Order complete jack assembly.
14	Early production models used a plunger and saddle combination. This has been replaced by a 1-piece solid plunger design.
17	Seal threads with Loctite #69-41. Torque to 18-22 ft-lbs.

### Repair Parts List, Figure 1

Item	Description	Qty.	Parts Kit	Qty.	Parts Kit
			JHA-156		JHA-356
4	Gasket	5	▲	5	■
11	Wiper Ring	1	▲	1	■
12	Stop Ring	1	CA267044	1	G91044
13	Base	1	N/A	1	N/A
14	Plunger	1	CR700040	1	CR707040
15	Relief Valve	1	P181190W	1	P181190W
16	Piston Plug	1	CB142006	1	DD8434009
17	Seat Assembly	2	DA3041900	2	DA3041900
18	G T Assembly	1	▲	1	■
19	O-Ring	3	▲	1	■
20	O-Ring	1	▲	1	■
21	Back-up Washer	1	▲	1	■
22	Piston Sleeves (incl. 20, 21, 22, 23, 24, 26)	1	CA55446SR	1	CA55446SR
23	O-Ring	1	▲	1	■
24	Back-up Washer	1	▲	1	■
25	Drive Pin	1	P7557	1	P7557
26	Pump Plunger	1	See item 22	1	See item 22
27	Beam	1	Y918060	1	Y918060
28	Beam Pin	1	Y991061	1	Y991061
29	Set Screw	1	Y990028	1	Y990028
30	Bladder	1	CR706025	1	CR708025
33	Cover Name Plate	1	CB127101	1	CB130101
35	Hex Head Screw 1/4-20 x 1" Lg.	1	B1458046	1	B1458046
36	Base Plug	1	CB141006	1	CB129006
37	Handle and Grip Assembly	1	CA298900	1	CA298900
38	O-Ring	-	N/A	2	■

**Notes:**

- ▲ included in Repair Kit JHA-156K.
- included in Repair Kit JHA-356K2.

Ⓢ **CAUTION:** Indicates staked threads. Stake mark must be removed prior to disassembly. Failure to do so may result in damage to parts.

Some cylinder stop rings are assembled with Loctite material on threads. Enerpac suggests staking threads when reassembling.

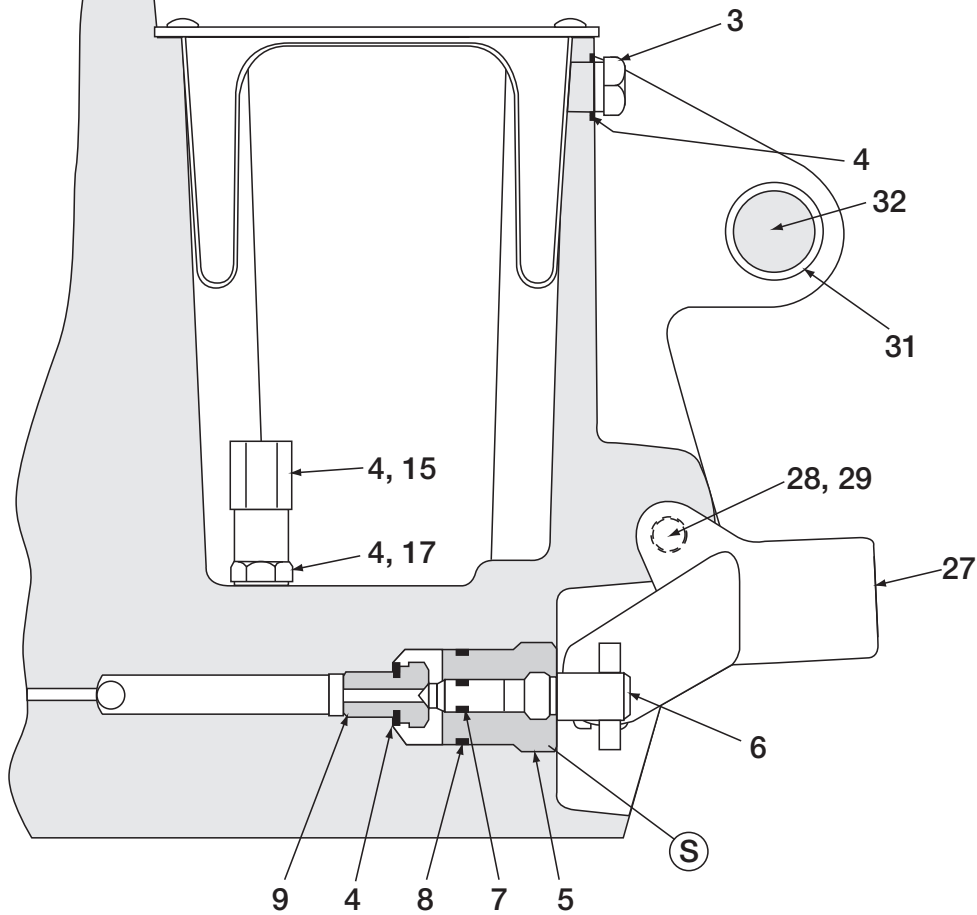

Figure 2



Note: See Page 4 for parts list.

(*) Notes	
4, 15	Use Loctite #69-41 hydraulic sealant on threads. Set relief valve at 9,900 to 10,000 psi for JHA-356 jacks. Set relief valve at 9,600 to 9,700 psi for JHA-156 jacks.
9	Seal threads of item 9 with Loctite #69-41. Torque to 18-22 ft-lbs.

## Repair Parts List, Figure 2

Item	Description	Qty.	Parts Kit	
			JHA-156	JHA-356
3	Filler plug	1	CA113006	CA113006
4	Gasket	5	▲	■
5	Release assembly Sleeve	1	Y845446	Y845446
6	Release valve	1	CA237950	CA237950
7	O-Ring	1	▲	■
8	O-Ring	1	▲	■
9	Seat	1	CA86290	CA86290
15	Relief Valve	1	P181190W	P181190W
17	Seat Assembly	2	DA3041900	DA3041900
27	Beam	1	Y918060	Y918060
28	Beam Pin	1	Y991061	Y991061
29	Set Screw	1	Y990028	Y990028
31	Retaining ring	2	▲	■
32	Handle	1	CA281070	CA305070

**Notes:**  
▲ included in Repair Kit JHA-156K.  
■ included in Repair Kit JHA-356K.

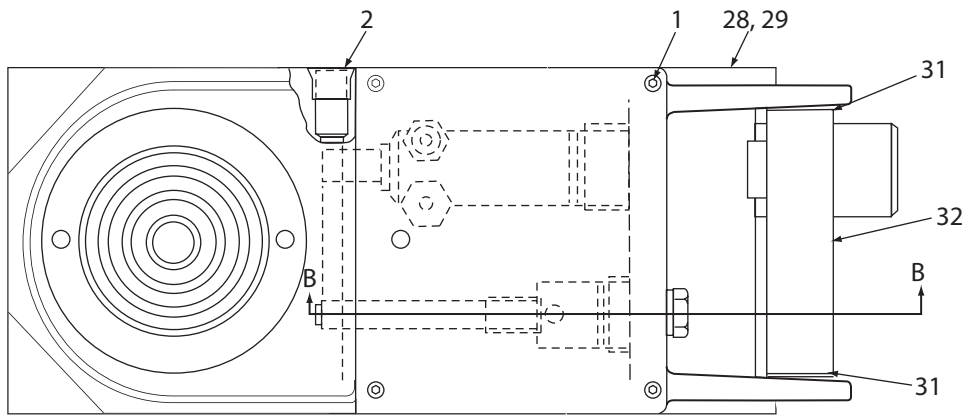

Figure 3

### Repair Parts List, Figure 3

Item	Description	Qty.	Parts Kit	
			JHA-156	JHA-356
1	Screw	4	F866028	F866028
2	Flush Plug	1	A1008245	A1008245
28	Beam Pin	1	Y991061	Y991061
29	Set Screw	1	Y990028	Y990028
31	Retaining Ring	2	▲	■
32	Handle	1	CA281070	CA305070

Notes:

- ▲ included in Repair Kit JHA-156K.
- included in Repair Kit JHA-356K.