

▼ Shown: S3000PX



Setting New Standards in Safety, Simplicity and Performance

Safety and Performance

- Compact, high-strength uni-body construction provides a small operating radius without sacrificing endurance
- 35° rotation angle and rapid return stroke for fast operation
- Tough manifold design with added safety feature for enhanced operator safety.

Simplicity

- 360° click-on reaction arm with quick release lever provides easier handling, even with gloves on
- Includes robust handle or lifting eye which mounts on both sides of tool for extra maneuverability
- Push button square drive release for quickly reversing the square drive for tightening or loosening.

Versatility

- Available with optional enhanced tilt and swivel TSP300 manifold for horizontal and vertical maneuverability, with greater durability ¹⁾

Accuracy

- Constant torque output provides accuracy of $\pm 3\%$ across full stroke
- Optional Angle-of-Turn Indicator provides measurement of rotation.

¹⁾ TSP300 is designed for X-Edition tools only, and is not compatible with previous edition tools. For replacement components for existing tools, refer to repair sheet on www.enerpac.com



Two Handle Styles

Robust angled positioning handle comes standard with every S-Series (X-Edition) tool. Straight positioning handles are available as accessories.

Compatible S-Series (X-Edition) wrenches	Model Nr. Angled positioning handles (standard)	Model Nr. Straight positioning handles (optional)
S1500X, S3000X	SWH6A	SWH6S
S6000X, S11000X	SWH10A	SWH10S
S25000X	SWH10EA ²⁾	

²⁾ SWH10EA is an lifting eye.



TSP - Pro Series Swivel

The optional TSP300 tilt and swivel manifold with robust interlocking design provides 360° X-axis rotation and 160° Y-axis rotation.

How to Order ¹⁾

Factory fitted to S-Series (X-Edition) wrenches: Insert a "P" prior to the "X" in the tool model number, example: **S1500PX**.

Order as an accessory using the model number: **TSP300**, which can be fitted to existing S-Series (X-Edition) wrenches. Includes male and female couplers.

Page: 215



ATEX declared. Calibration certificate included.

All X-edition tools are CE - ATEX declared and are shipped complete with a calibration certificate.

X-Edition, Square Drive Hydraulic Torque Wrenches

Standard are: ① ② ⑥ ⑧
Other items are optional.

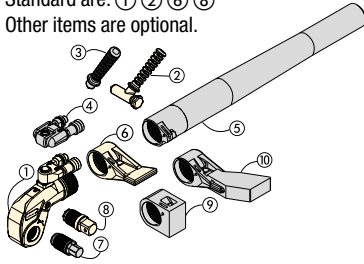

- ① Drive Unit
- ② Angeled Positioning Handle
- ③ Straight Positioning Handle
- ④ Pro Series Swivel
- ⑤ Reaction Tube Extension
- ⑥ Standard Reaction Arm
- ⑦ Allen-Key Drive
- ⑧ Square Drive
- ⑨ Short Reaction Arm
- ⑩ Extended Reaction Arm

Select the Right Torque
Choose your Enerpac Torque Wrench using the untightening rule of thumb:
Loosening torque equals about 250% of tightening torque.

S Series X-Edition



Nominal Torque Output:

35.455 Nm

Square Drive Range:

3/4 - 2 1/2 inch

Nose Radius:

25 - 64 mm

Maximum Operating Pressure:

690 bar

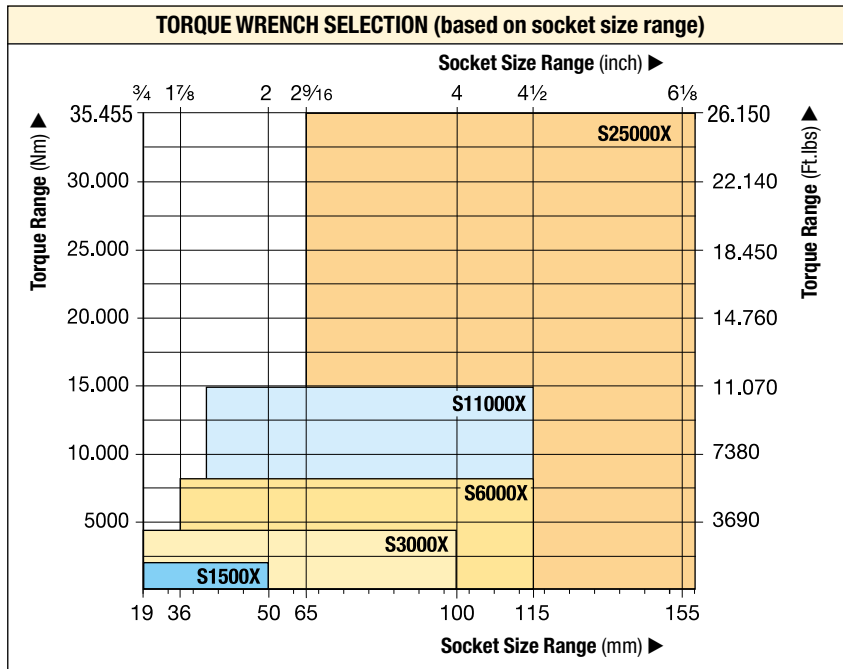

Back-Up Spanners
Hands free tool to be used to stop the back nut from turning during make up or break out.

Page: **217**

Use only Heavy Duty Impact Sockets
For power driven torquing equipment, according to ISO2725 and ISO1174; DIN 3129 and DIN 3121 or ASME-B107.2/1995.

Page: **216**

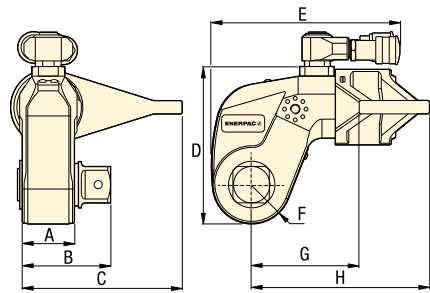

Safe™ Torque Lock
The Safe™ Torque Lock is suitable for all bolted applications from 190 Nm to 15.000 Nm using a heavy duty impact socket.

The patented mechanical locking system creates a hands-free torque wrench solution suitable for Enerpac only square drive tools.

Suitable for S3000X, S6000X and S11000X.

Page: **218**

Nominal Torque at 690 bar		Minimum Torque at 69 bar		Square Drive Size (inch)		Angle-of-Turn Model Nr. (optional)	Torque Wrench Model Number *	Dimensions (mm)								
(Nm)	(Ft.lbs)	(Nm)	(Ft.lbs)		Model Nr. (included with wrench)			A	B	C	D	E	F	G	H	(kg)
1952	1440	195	144	3/4	SD15-012	AOT15	S1500X	39	65	108	97	136	25	70	129	3,2
4373	3225	438	323	1	SD30-100	AOT30	S3000X	48	78	135	128	173	33	90	161	5,6
8338	6150	834	615	1 1/2	SD60-108	AOT60	S6000X	55	92	169	157	192	40	110	188	9,2
15.151	11.175	1516	1118	1 1/2	SD110-108	AOT110	S11000X	72	114	197	190	228	50	133	229	15,8
35.455	26.150	3545	2615	2 1/2	SD250-208	AOT250	S25000X	89	143	246	244	287	64	182	295	32,2

* To order a S-Series (X-edition) torque wrench fitted with a TSP300 tilt and swivel manifold, insert a "P" prior to the "X" in the tool model number, example: **S1500PX**.

Maximum Torque at 690 bar:

35.455 Nm

Hexagon Size Allen Drive:

1/2 - 2 1/4 inch

Hexagon Size Allen Drive:

14 - 85 mm

For
S
Series

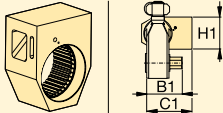

Torque Wrench 	Optional Allen Drives, Imperial				Optional Allen Drives, Metric				Short Reaction Arm for Allen Drives 		
	Hexagon Size ¹⁾ (inch)	Maximum Torque (Nm)	Model Number	Dim. B1 (mm)	Hexagon Size ¹⁾ (mm)	Maximum Torque (Nm)	Model Number	Dim. B1 (mm)	Model Number	Dimensions (mm) C1 H1	
S1500X (1952 Nm)	1/2	481	SDA15008	66	14	644	SDA1514	66	SRA15X	67,5	74
	5/8	936	SDA15010	67	17	1152	SDA1517	68			
	3/4	1620	SDA15012	71	19	1607	SDA1519	70			
	7/8	1952	SDA15014	74	22	1952	SDA1522	73			
	1	1952	SDA15100	77	24	1952	SDA1524	74			
S3000X (4373 Nm)	5/8	936	SDA30010	77	17	1152	SDA3017	77	SRA30X	80,0	74
	3/4	1620	SDA30012	80	19	1607	SDA3019	79			
	7/8	2569	SDA30014	83	22	2488	SDA3022	82			
	1	3830	SDA30100	86	24	3234	SDA3024	84			
	1 1/8	4373	SDA30102	88	27	4373	SDA3027	85			
	1 1/4	4373	SDA30104	89	30	4373	SDA3030	87			
	-	-	-	-	32	4373	SDA3032	88			
S6000X (8338 Nm)	5/8	936	SDA60010	85	17	1152	SDA6017	86	SRA60X	91,5	89
	3/4	1620	SDA60012	89	19	1607	SDA6019	88			
	7/8	2569	SDA60014	92	22	2488	SDA6022	91			
	1	3830	SDA60100	95	24	3234	SDA6024	93			
	1 1/8	5457	SDA60102	97	27	4603	SDA6027	94			
	1 1/4	7484	SDA60104	98	30	6311	SDA6030	96			
	-	-	-	-	32	7660	SDA6032	97			
S11000X (15.151 Nm)	1 1/4	7484	SDA110104	115	30	6311	SDA11030	112	SRA110X	127,5	106
	1 3/8	9958	SDA110106	117	32	7660	SDA11032	114			
	1 1/2	12.928	SDA110108	118	36	10.901	SDA11036	117			
	1 5/8	15.151	SDA110110	122	41	15.151	SDA11041	121			
	1 3/4	15.151	SDA110112	125	46	15.151	SDA11046	127			
S25000X (35.455 Nm)	1 1/2	12.928	SDA250108	141	36	10.901	SDA25036	140	SRA250X	158,5	135
	1 5/8	16.433	SDA250110	145	41	16.107	SDA25041	144			
	1 3/4	20.520	SDA250112	148	46	22.744	SDA25046	148			
	1 7/8	25.245	SDA250114	149	50	29.211	SDA25050	151			
	2	30.635	SDA250200	151	55	35.455	SDA25055	154			
	2 1/4	35.455	SDA250204	154	60	35.455	SDA25060	158			
	-	-	-	-	65	35.455	SDA25065	161			
	-	-	-	-	70	35.455	SDA25070	164			
	-	-	-	-	75	35.455	SDA25075	168			
	-	-	-	-	85	35.455	SDA25085	175			

¹⁾ See page 407 for table of hexagon sizes of bolts, nuts and related thread diameters.

Accessories for S-Series, X-Edition Wrenches

TSP RTEX SRSX Series



TSP-Series, Pro Series Swivel

- Robust interlocking design
- 360° X-axis and 160° Y-axis rotation
- Increases tool fit in restricted access areas
- Simplifies hose placement
- Includes male and female couplers

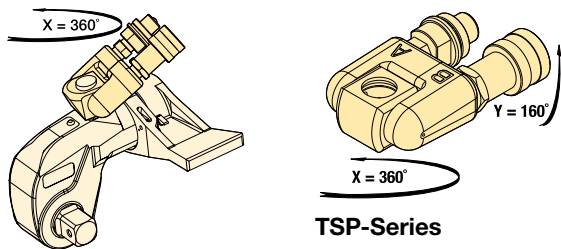

For Torque Wrench Model Number	Model Number ¹⁾	Maximum Pressure (bar)	Weight (kg)
S1500X, S3000X, S6000X, S11000X, S25000X	TSP300	690	0,2

¹⁾ To order a S-Series (X-edition) torque wrench fitted with a TSP300 tilt and swivel manifold, insert a "P" prior to the "X" in the tool model number, example: **S1500PX**. TSP300 is designed for X-Edition tools only, and is not compatible with standard edition tools. For replacement components for existing tools, refer to repair sheet on www.enerpac.com

RTEX-Series, Reaction Tube Extensions

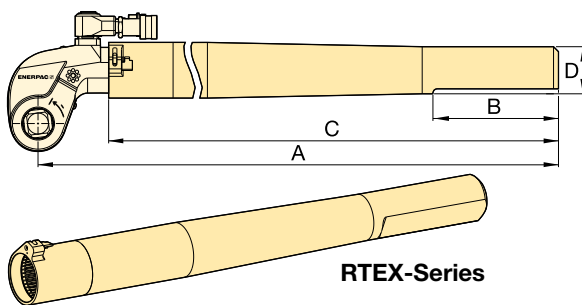

- Full torque rated
- Increases tool fit in restricted access areas

For Torque Wrench Model Number	Model Number	Dimensions (mm)				Weight (kg) *
		A	B	C	D	
S1500X	RTE15X	706	152	636	58	4,6
S3000X	RTE30X	733	152	647	57	5,5
S6000X	RTE60X	747	152	659	65	7,7
S11000X	RTE110X	769	152	675	76	11,2
S25000X	RTE250X	813	152	685	100	17,3

* Weights indicated are for the accessories only and do not include the wrench.

SRSX-Series, Extended Reaction Arms

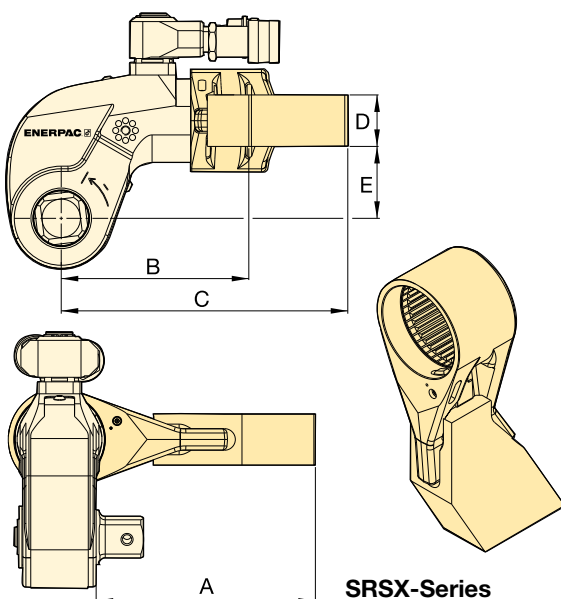

- Lightweight interchangeable design

For Wrench Model	Max. Torque (Nm)	Model Number	Dimensions (mm)					Weight (kg) *
			A	B	C	D	E	
S1500X	1801	SRS151X	94	86	127	24	34	0,8
	1641	SRS152X	119	97	138	24	34	1,0
	1533	SRS153X	145	109	148	24	34	1,2
S3000X	3918	SRS301X	111	106	168	34	48	1,6
	3712	SRS302X	137	117	182	34	48	2,0
	3574	SRS303X	162	132	198	34	48	2,5
S6000X	7842	SRS601X	138	128	192	39	62	2,3
	7454	SRS602X	163	144	207	39	62	2,7
	7175	SRS603X	189	159	222	39	62	3,4
S11000X	14.650	SRS1101X	149	157	232	46	76	4,4
	13.957	SRS1102X	175	172	247	46	76	5,1
	13.391	SRS1103X	200	187	261	46	76	5,8
S25000X	33.538	SRS2501X	183	209	295	50	100	7,6
	32.049	SRS2502X	208	222	310	50	100	8,4
	30.750	SRS2503X	233	236	326	50	100	10,0

* Weights indicated are for the accessories only and do not include the wrench.