

# Swing Clamps

## Swing Clamps

Enerpac's complete line of swing clamps provides maximum clamping force in the smallest possible package. With several mounting and operation styles available, Enerpac can fit any clamping need you can think of. Our unique patented clamp arm design is an industry exclusive, and makes Enerpac's swing cylinder line more versatile than ever before. Made to the highest quality standards, Enerpac swing clamps will provide maximum performance and trouble free operation.



## Technical support





Refer to the "Yellow Pages" of this catalog for:

- Safety instructions
- Basic hydraulic information
- Advanced hydraulic technology
- FMS (Flexible Machining Systems) technology
- Conversion charts and hydraulic symbols

 197 ▶

▼ series

▼ page

<b>Swing cylinder range overview</b>		<b>22 - 23</b>	
Upper flange swing clamps	SU	24 - 25	
Lower flange swing clamps	SL	26 - 27	
Threaded body swing clamps	ST	28 - 29	
Cartridge model swing clamps	SC	30 - 31	
Clamp arms	CAS CAL	32 - 33	
Pivoting T-arms	CAC CAPT	34 - 35	
Upreach clamp arms	CAU	36 - 37	
Swing clamps	SC	38	
Swing clamps	ASC	39	
Three-position swing clamps	WTR	40 - 41	

# Swing clamps *Application & selection*

Collet-Lok® products

Swing clamps

Shown: SCRD-122, STLD-22, SLRS-202



► Enerpac swing clamps allow unobstructed part fixturing and placement. The plunger rod and the attached clamp arm rotate 90 degrees in either a clockwise or counter-clockwise direction, then travel down an additional distance to clamp against the fixtured part. Upon release of clamping pressure, the clamp arm rotates back 90 degrees in the opposite direction to allow for part removal and new part placement.

### Roller in groove

- Double index provides low height design to minimize fixture height
- Overload clutch allows clamp to disengage if needed to prevent damage due to improper part loading

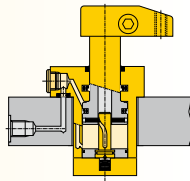

### Ball in groove

- Rotation direction can be changed on-site to reduce spare inventory by 2/3 (67%)
- Ball and cam rotation ensures smooth accurate operation

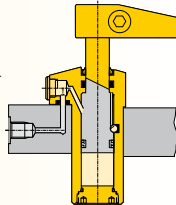

■ *Swing clamps used in conjunction with work supports and other Enerpac components to positively hold the workpieces during machining operations.*

## Compact and full featured design

- Compact design allows for efficient fixture layout
- Variety of mounting styles to meet design needs
- Double and single-acting cylinders to suit a variety of hydraulic requirements
- Choice of porting styles to meet system and design requirements
- All cylinders are available as left and right turning models
- Large ball and cam design on 22, 52 and 121 models allows swing rotation to be changed easily
- Overload clutch mechanism on 92, 202, and 352 models prevents damage to cylinder from high flow rates or misapplication.

## i Select your swing cylinder type:

### Single acting

- The obvious choice when there are few system restrictions, and there are not many units retracting simultaneously
- Fewer valving requirements which results in a less complex circuit
- Innovative clamp arm design allows quick and secure arm positioning.

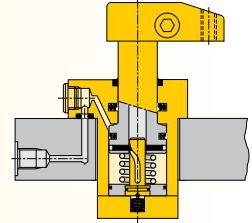

### Double acting

- Used when greater control is required during the unclamp cycle
- When timing sequences are critical: less sensitive to system back pressures, resulting from long tube lengths or numerous components being retracted at the same time
- Innovative clamp arm design allows quick and secure arm positioning.

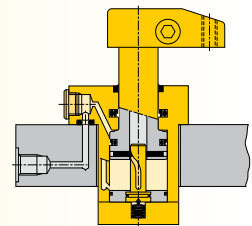

For Collet-Lok® positive locking swing clamps, see 12 ▶

## Select your mounting method:

### SU series, Upper flange mounting

- Flexible design allows for manifold or threaded oil port connection
- Fixture hole does not require tight tolerances
- Easy installation with only 3 or 4 mounting bolts.

 24 ▶

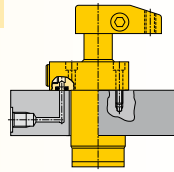

### SL series, Lower flange mounting

- Flexible design allows for manifold or threaded port connection
- No fixture hole required
- Easy installation with only 3 or 4 mounting bolts.

 26 ▶

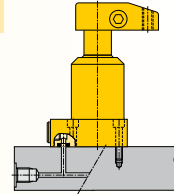

### ST series, Threaded body mounting

- Body thread for precise cylinder height positioning
- Threaded oil port connection
- Can be threaded directly into the fixture and secured in position by means of standard flange nuts.

 28 ▶

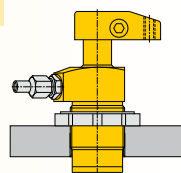



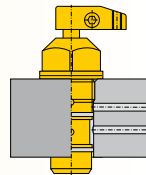

### SC series, Cartridge mounting

- Minimal space required on fixture
- External plumbing not required
- Allows close positioning of adjoining units
- Cylinder can be completely recessed in fixture.

 30 ▶

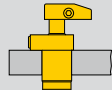

## Product selection

Clamping force <sup>1)</sup>	Stroke		Upper flange	Lower flange	Threaded body	Cartridge
	kN	mm				
	clamping	total				
<b>▼ Single acting</b>						
	Model number <sup>2)</sup>					
2,1	8,1	16,4	<b>SURS-22</b>	<b>SLRS-22</b>	<b>STRS-22</b>	<b>SCRS-22</b>
4,9	9,9	22,6	<b>SURS-52</b>	<b>SLRS-52</b>	<b>STRS-52</b>	<b>SCRS-52</b>
8,0	11,9	23,0	<b>SURS-92</b>	<b>SLRS-92</b>	<b>STRS-92</b>	-
10,7	12,7	27,9	<b>SURS-121</b>	<b>SLRS-121</b>	<b>STRS-121</b>	<b>SCRS-122</b>
17,4	14,0	29,5	<b>SURS-202</b>	<b>SLRS-202</b>	<b>STRS-202</b>	-
33,1	16,0	32,6	<b>SURS-352</b>	<b>SLRS-352</b>	<b>STRS-352</b>	-
<b>▼ Double acting</b>						
	Model number <sup>2)</sup>					
2,2	8,1	16,4	<b>SURD-22</b>	<b>SLRD-22</b>	<b>STRD-22</b>	<b>SCRD-22</b>
5,6	9,9	22,6	<b>SURD-52</b>	<b>SLRD-52</b>	<b>STRD-52</b>	<b>SCRD-52</b>
9,0	11,9	23,0	<b>SURD-92</b>	<b>SLRD-92</b>	<b>STRD-92</b>	-
9,0	32,0	43,0	<b>SURDL-92*</b>	-	-	-
11,6	12,7	27,9	<b>SURD-121</b>	<b>SLRD-121</b>	<b>STRD-121</b>	<b>SCRD-122</b>
11,6	31,8	47,0	<b>SURDL-121</b>	-	-	-
18,7	14,0	29,5	<b>SURD-202</b>	<b>SLRD-202</b>	<b>STRD-202</b>	-
33,8	16,0	32,6	<b>SURD-352</b>	<b>SLRD-352</b>	<b>STRD-352</b>	-
33,8	31,8	48,4	<b>SURDL-352*</b>	-	-	-



<sup>1)</sup> With standard clamp arm. Clamp arms are sold separately ( 32). Clamping forces for single-acting models are reduced in order to overcome return spring force. <sup>2)</sup> For left turning swing clamps replace the R in the model number for an L. **Note:** Call Enerpac to order models with imperial thread and SAE port connections.

\* This product is made to order. Please contact Enerpac for delivery information before specifying in your design.  
[www.enerpacwh.com](http://www.enerpacwh.com)

Force: 2,1 - 33,8 kN

Stroke: 16,4 - 48,4 mm

Pressure: 35 - 350 bar

-  Cilindros giratorios
-  Vérins de bridage pivotants
-  Schwenkspannzylinder

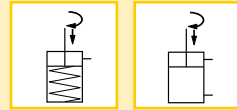

## Options

Available as both left and right turning

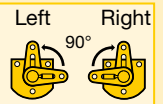

### Clamp arms

 32 ▶



### Work supports

 43 ▶



### Accessories

 86 ▶



## Important

Actual clamping may only take place when the cylinder has completed its 90° swing.

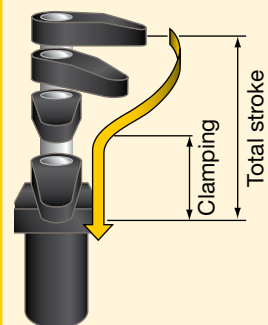

All swing clamps have swing angle repeatability of  $\pm 1^\circ$ .

Other swing angles available upon request.  
 Contact Enerpac for info.

# Swing clamps - Upper flange models

Shown: SURS-52, SURS-202



## SU series

The Enerpac upper flange swing clamps are designed for integrated manifold mounting solutions. Hydraulic connections are made through SAE or BSP oil connection or the standard integrated O-ring ports.

BSP oil connection

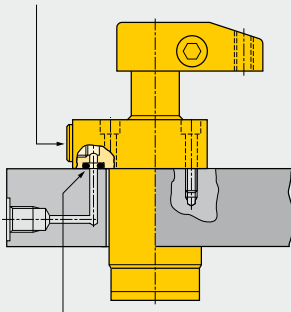

Integrated O-ring port

■ Enerpac upper flange swing clamps integrated into a fully automated machining system.



## Minimal mounting height

...when space is at a premium

- Flexible design allows for manifold or threaded port connection
- Low profile mounting style allows body to be below mounting surface
- Simple mounting preparation and easy installation – 3 or 4 mounting bolts
- Double oil connection – threaded port or manifold mount
- Symmetrical rectangular flange design enables clamping at three sides of the cylinder
- 30, 45, and 60 degree swing angles available on request .

## Product selection

Clamping force <sup>1)</sup>	Stroke		Left turning 90°	Right turning 90°	Cylinder effective area	Oil capacity		Max. oil flow <sup>1)</sup>	Standard clamp arm	
	kN	mm				cm <sup>2</sup>	cm <sup>3</sup>			
	Clamp	Total			Clamp	Un-clamp	Clamp	Un-clamp	Sold separately	
<b>▼ Single acting</b>										
Model number <sup>2)</sup>										
2,1	8,1	16,4	<b>SULS-22</b>	<b>SURS-22</b>	0,77	–	1,31	–	0,2	<b>CAS-22</b>
4,9	9,9	22,6	<b>SULS-52</b>	<b>SURS-52</b>	1,81	–	4,10	–	0,4	<b>CAS-52</b>
8,0	11,9	23,0	<b>SULS-92</b>	<b>SURS-92</b>	3,16	–	6,88	–	1,0	<b>CAS-92</b>
10,7	12,7	27,9	<b>SULS-121</b>	<b>SURS-121</b>	4,06	–	11,47	–	1,6	<b>CAS-121</b>
17,4	14,0	29,5	<b>SULS-202</b>	<b>SURS-202</b>	7,10	–	19,99	–	2,3	<b>CAS-202</b>
33,1	16,0	32,6	<b>SULS-352</b>	<b>SURS-352</b>	12,39	–	37,20	–	3,9	<b>CAS-352</b>
<b>▼ Double acting</b>										
Model number <sup>2)</sup>										
2,2	8,1	16,4	<b>SULD-22</b>	<b>SURD-22</b>	0,77	1,55	1,31	2,62	0,2	<b>CAS-22</b>
5,6	9,9	22,6	<b>SULD-52</b>	<b>SURD-52</b>	1,81	3,81	4,10	8,69	0,4	<b>CAS-52</b>
9,0	11,9	23,0	<b>SULD-92</b>	<b>SURD-92</b>	3,16	8,06	6,88	17,70	1,0	<b>CAS-92</b>
9,0	32,0	43,0	<b>SULD-92*</b>	<b>SURDL-92*</b>	3,16	8,06	13,27	30,48	1,0	<b>CAS-92</b>
11,6	12,7	27,9	<b>SULD-121</b>	<b>SURD-121</b>	4,06	7,94	11,47	22,94	1,6	<b>CAS-121</b>
11,6	31,8	47,0	<b>SULD-121</b>	<b>SURDL-121</b>	4,06	7,94	15,90	37,69	1,6	<b>CAS-121</b>
18,7	14,0	29,5	<b>SULD-202</b>	<b>SURD-202</b>	7,10	15,16	19,99	42,61	2,3	<b>CAS-202</b>
33,8	16,0	32,6	<b>SULD-352</b>	<b>SURD-352</b>	12,39	23,74	37,20	71,28	3,9	<b>CAS-352</b>
33,8	31,8	48,4	<b>SULD-352*</b>	<b>SURDL-352*</b>	12,39	23,74	57,85	110,94	3,9	<b>CAS-352</b>

<sup>1)</sup> With standard clamp arm. Clamp arms are sold separately (□ 32). Clamping forces for single-acting models are reduced in order to overcome return spring force.

<sup>2)</sup> For models with straight plunger movement, replace L or R with S.

\* This product is made to order. Please contact Enerpac for delivery information before specifying in your design.

**Note:** Call Enerpac to order models with SAE port connections.

## Dimensions in mm [ ]

Left turning models	A	B	C	C1	D	D1	D2	F	G	H	K	M
						∅		∅				
<b>▼ Single acting</b>												
<b>SULS-22</b>	112,1	59,0	26,7	43,0	27,9	47,2	45,0	10,0	G1/8"	11,2	16,0	-
<b>SULS-52</b>	135,3	69,3	27,4	50,1	34,8	54,0	57,2	16,0	G1/8"	9,9	19,2	-
<b>SULS-92</b>	144,2	76,3	28,2	51,2	47,9	70,0	54,0	25,0	G1/4"	13,0	25,0	15,0
<b>SULS-121</b>	171,5	85,7	27,4	55,3	47,5	66,4	73,2	22,2	SAE #4	9,9	30,4	-
<b>SULS-202</b>	167,0	88,1	28,4	58,0	62,6	85,0	70,0	32,0	G1/4"	13,0	30,1	23,2
<b>SULS-352</b>	189,3	100,7	28,2	60,7	76,8	100,0	89,0	38,0	G1/4"	13,0	40,0	27,4
<b>▼ Double acting</b>												
<b>SULD-22</b>	112,1	59,0	26,7	43,0	27,9	47,2	45,0	10,0	G1/8"	11,2	16,0	-
<b>SULD-52</b>	135,3	69,3	27,4	50,1	34,8	54,0	57,2	16,0	G1/8"	9,9	19,2	-
<b>SULD-92</b>	144,2	76,3	28,2	51,2	47,9	70,0	54,0	25,0	G1/4"	13,0	25,0	-
<b>SULD-92*</b>	184,2	96,3	28,2	71,2	47,9	70,0	54,0	25,0	G1/4"	13,0	25,0	-
<b>SULD-121</b>	171,5	85,7	27,4	55,3	47,5	66,4	73,2	22,2	SAE #4	9,9	30,4	-
<b>SULD-121</b>	228,7	104,7	27,4	74,4	47,5	66,4	73,2	22,2	SAE #4	9,9	30,4	-
<b>SULD-202</b>	167,0	88,1	28,4	58,0	62,6	85,0	70,0	32,0	G1/4"	13,0	30,1	-
<b>SULD-352</b>	189,3	100,7	28,2	60,7	76,8	100,0	89,0	38,0	G1/4"	13,0	40,0	-
<b>SULD-352*</b>	220,9	116,5	28,2	76,5	76,8	100,0	89,0	38,0	G1/4"	13,0	40,0	-

**NOTE:** dimensions shown with standard clamp arm.

\* This product is made to order. Please contact Enerpac for delivery information before specifying in your design.

**A** Installation dimensions in mm

Clamping force <sup>1)</sup> kN	Fixture hole Ø D3	Mounting thread J	Min. depth J2	Manifold O-ring <sup>2)</sup> ARP number or inside Ø x thickness
2,2	28,5	M5 x 0,8	16,5	568-010
5,6	35,5	M6 x 1,0	16,5	568-011
9,0	49,0	M6	15,0	4,32 x 3,53
11,6	49,0	.312-24 UNF	20,3	568-011
18,7	63,5	M8 x 1,0	17,0	4,32 x 3,53
33,8	78,0	M10 x 1,25	18,8	4,32 x 3,53

<sup>1)</sup> With standard clamp arm.  
<sup>2)</sup> Polyurethane, 92 Durometer

**Note:** Mounting bolts and O-rings included.

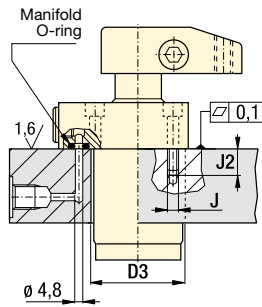

**-92, 52, 121**

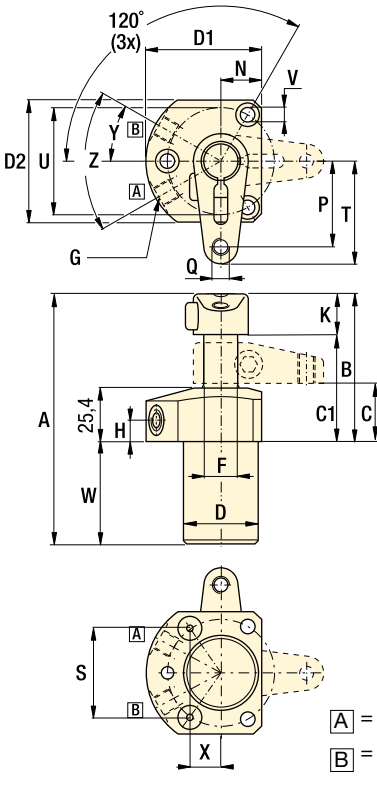

**-92, 202, 352**

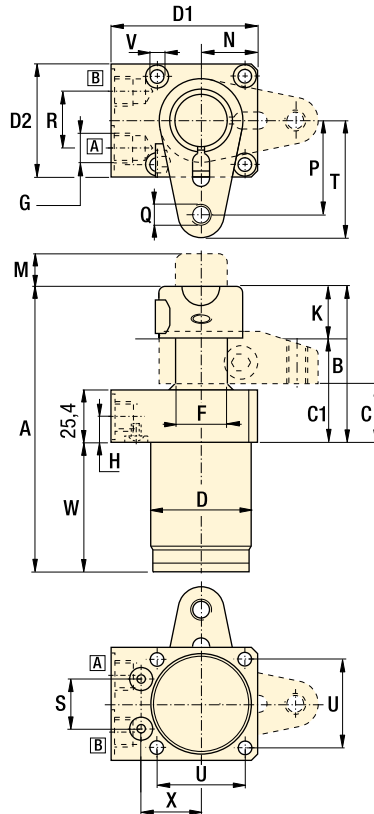

**A** = Clamping  
**B** = Unclamping (venting)

<b>Force:</b> 2,1 - 33,8 kN
<b>Stroke:</b> 16,4 - 48,4 mm
<b>Pressure:</b> 35 - 350 bar

- E** Cilindros giratorios
- F** Vérins de bridage pivotants
- D** Schwenkspannzylinder

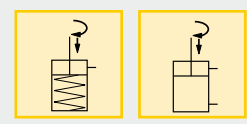

**Options**

- Clamp arms** [32](#)
- Work supports** [43](#)
- Collet-Lok® swing cylinders** [12](#)
- Accessories** [86](#)

**Important**

30, 45, and 60 degree rotations are available upon request. Add -30, -45 or -60 to end of standard model number to order directly from Enerpac. To order rotation limiter separately, see page 58.

Custom cylinders including longer stroke lengths are available on request.

In case there is a risk of machining coolants and debris being inhaled via the breather vent, it is recommended to pipe this port to an area outside the fixture that is protected from machining coolants and debris.

Do not exceed maximum flow rates.

N	P	Q	R	S	T	U	V	W	X	Y	Z	kg	Right turning models
													<b>Single acting ▼</b>
15,5	24,6	M6 x 1	-	21,0	30,9	41,9	5,7	53,1	18,1	30°	60°	0,5	<b>SURS-22</b>
19,1	40,0	M8 x 1,25	-	41,0	47,9	50,0	6,8	66,0	14,4	30°	60°	1,1	<b>SURS-52</b>
26,4	45,9	M10 x 1,5	26,0	23,7	56,0	42,0	6,5	67,9	28,6	-	-	2,0	<b>SURS-92</b>
25,1	51,4	.375-16 UNC	-	52,0	61,8	63,5	8,8	85,9	18,2	30°	60°	1,6	<b>SURS-121</b>
34,4	55,2	M12 x 1,75	26,0	29,1	70,2	55,0	8,5	78,9	35,1	-	-	3,5	<b>SURS-202</b>
43,4	67,9	M16 x 2	26,0	34,4	82,9	70,0	10,8	88,6	41,6	-	-	5,5	<b>SURS-352</b>
													<b>Double acting ▼</b>
15,5	24,6	M6 x 1	-	21,0	30,9	41,9	5,7	53,1	18,1	30°	60°	0,5	<b>SURD-22</b>
19,1	40	M8 x 1,25	-	41,0	47,9	50,0	6,8	66,0	14,4	30°	60°	1,1	<b>SURD-52</b>
26,4	45,9	M10 x 1,5	26,0	23,7	56,0	42,0	6,5	67,9	28,6	-	-	2,0	<b>SURD-92</b>
26,4	45,9	M10 x 1,5	26,0	23,7	56,0	42,0	6,5	87,9	28,6	-	-	2,6	<b>SURDL-92*</b>
25,1	51,4	.375-16 UNC	-	52,0	61,8	63,5	8,8	85,9	18,2	30°	60°	1,6	<b>SURD-121</b>
25,1	51,4	.375-16 UNC	-	52,0	61,8	63,5	8,8	124,0	18,2	30°	60°	1,8	<b>SURDL-121</b>
34,4	55,2	M12 x 1,75	26,0	29,1	70,2	55,0	8,5	78,9	35,1	-	-	3,5	<b>SURD-202</b>
43,4	67,9	M16 x 2	26,0	34,4	82,9	70,0	10,8	88,6	41,6	-	-	5,5	<b>SURD-352</b>
43,4	67,9	M16 x 2	26,0	34,4	82,9	70,0	10,8	104,3	41,6	-	-	6,9	<b>SURDL-352*</b>

Swing Clamps  
 Work Supports  
 Linear Cylinders  
 Power Sources  
 Valves  
 Pallet Components  
 System Components  
 Yellow Pages

# Swing clamps - Lower flange models

Shown: SLRD-52, SLRS-202



## SL series

Enerpac lower flange series swing clamps can be bolted to the fixture, allowing easy installation of the unit and does not require machined fixture holes. Hydraulic connections are made through SAE or BSPP oil connection or the standard integrated O-ring ports.

BSPP oil connection

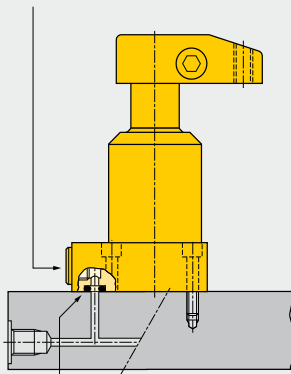

Integrated O-ring port

Lower flange swing clamps mounted to the face of the fixture.





## No fixture hole required

...cylinder can be bolted directly to fixture

- Flexible design allows for manifold or threaded port connection
- No fixture hole preparation required
- Easiest mounting preparation in the swing cylinder line
- Symmetrical rectangular flange design enables clamping at three sides of the cylinder
- Allows extra large parts to be clamped
- 30, 45 and 60 degree swing angles available on request.

## Product selection

Clamping force <sup>1)</sup> kN	Stroke mm		Left turning 90° 	Right turning 90° 	Cylinder effective area cm <sup>2</sup>		Oil capacity cm <sup>3</sup>		Max. oil flow <sup>1)</sup> l/min	Standard clamp arm Sold separately  32 ▶
	Clamp	Total			Un-clamp	Clamp	Un-clamp	Clamp		
▼ Single acting										
Model number <sup>2)</sup>										
2,1	8	16,5	<b>SLLS-22</b>	<b>SLRS-22</b>	0,77	–	1,31	–	0,2	<b>CAS-22</b>
4,9	10	22,6	<b>SLLS-52</b>	<b>SLRS-52</b>	1,81	–	4,10	–	0,4	<b>CAS-52</b>
8,0	12	23,0	<b>SLLS-92</b>	<b>SLRS-92</b>	3,16	–	6,88	–	1,0	<b>CAS-92</b>
10,7	13	27,9	<b>SLLS-121</b>	<b>SLRS-121</b>	4,06	–	11,47	–	1,6	<b>CAS-121</b>
17,4	14	29,5	<b>SLLS-202</b>	<b>SLRS-202</b>	7,10	–	19,99	–	2,3	<b>CAS-202</b>
33,1	16	32,6	<b>SLLS-352</b>	<b>SLRS-352</b>	12,39	–	37,20	–	3,9	<b>CAS-352</b>

▼ Double acting										
Model number <sup>2)</sup>										
2,2	8	16,5	<b>SLLD-22</b>	<b>SLRD-22</b>	0,77	1,55	1,31	2,62	0,2	<b>CAS-22</b>
5,6	10	22,6	<b>SLLD-52</b>	<b>SLRD-52</b>	1,81	3,81	4,10	8,69	0,4	<b>CAS-52</b>
9,0	12	23,0	<b>SLLD-92</b>	<b>SLRD-92</b>	3,26	8,06	6,88	17,70	1,0	<b>CAS-92</b>
11,6	13	27,9	<b>SLLD-121</b>	<b>SLRD-121</b>	4,06	7,94	11,47	22,94	1,6	<b>CAS-121</b>
18,7	14	29,5	<b>SLLD-202</b>	<b>SLRD-202</b>	7,10	15,26	19,99	42,61	2,3	<b>CAS-202</b>
33,8	16	32,6	<b>SLLD-352</b>	<b>SLRD-352</b>	12,39	23,74	37,20	71,38	3,9	<b>CAS-352</b>

<sup>1)</sup> With standard clamp arm. Clamp arms are sold separately (page 32). Clamping forces for single-acting models are reduced in order to overcome return spring force.»

<sup>2)</sup> For models with straight plunger movement, replace L or R with S.

**Note:** Call Enerpac to order models with SAE port connections.

## Dimensions in mm [ ]

Left turning models	A	C	C1	D	D1	D2	F	G	H	K	M
				∅			∅				
▼ Single acting											
<b>SLLS-22</b>	112,1	79,5	96,1	27,9	47,2	45,0	10,0	G1/8"	13,5	16,0	–
<b>SLLS-52</b>	135,3	93,5	116,1	34,8	54,0	57,2	16,0	G1/8"	14,0	19,3	–
<b>SLLS-92</b>	152,2	104,1	127,1	47,9	70,0	54,0	25,0	G1/4"	12,5	25,0	15,0
<b>SLLS-121</b>	171,5	113,3	141,2	47,5	66,4	73,2	22,2	SAE#4	15,4	30,4	–
<b>SLLS-202</b>	175,0	115,3	144,9	63,8	85,0	70,0	32,0	G1/4"	12,5	30,2	23,2
<b>SLLS-352</b>	197,3	124,7	157,3	79,7	100,0	89,0	38,0	G1/4"	12,5	40,0	27,4
▼ Double acting											
<b>SLLD-22</b>	112,1	79,5	96,1	27,9	47,2	45,0	10,0	G1/8"	13,5	16,0	–
<b>SLLD-52</b>	135,3	93,5	116,1	34,8	54,0	57,2	16,0	G1/8"	14,0	19,3	–
<b>SLLD-92</b>	152,2	104,1	127,1	47,9	70,0	54,0	25,0	G1/4"	12,5	25,0	–
<b>SLLD-121</b>	171,5	113,3	141,2	47,5	66,4	73,2	22,2	SAE#4	15,4	30,4	–
<b>SLLD-202</b>	175,0	115,3	144,9	63,8	85,0	70,0	32,0	G1/4"	12,5	30,2	–
<b>SLLD-352</b>	197,3	124,7	157,3	79,7	100,0	89,0	38,0	G1/4"	12,5	40,0	–

NOTE: dimensions shown with standard clamp arm.

**Installation dimensions** in mm

Clamping force <sup>1)</sup> kN	Mounting thread J	Minimum thread depth J2	Manifold O-ring <sup>2)</sup> ARP number or inside Ø x thickness
2,2	M5 x 0,8	16,5	568-010
5,6	M6 x 1,0	16,5	568-011
9,0	M6 x 1,0	15,0	4,32 x 3,53
11,6	312-24 UNF	20,3	568-011
18,7	M8 x 1,0	17,0	4,32 x 3,53
33,8	M10 x 1,25	18,8	4,32 x 3,53

<sup>1)</sup> With standard clamp arm.  
<sup>2)</sup> Polyurethane, 92 Durometer

**Note:** Mounting bolts and O-rings included.

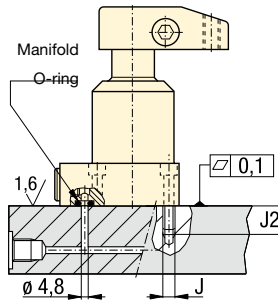

**-22, 52, 121**

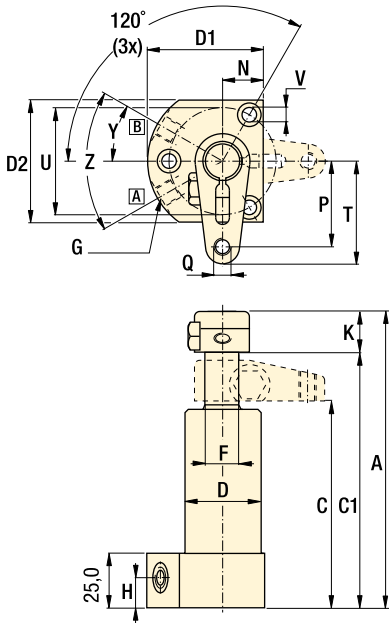

**-92, 202, 352**

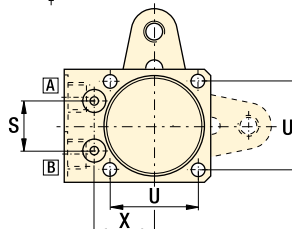
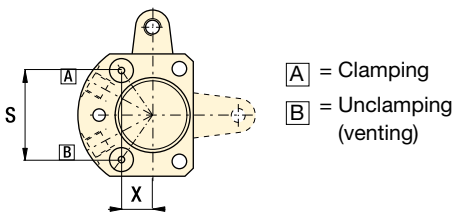
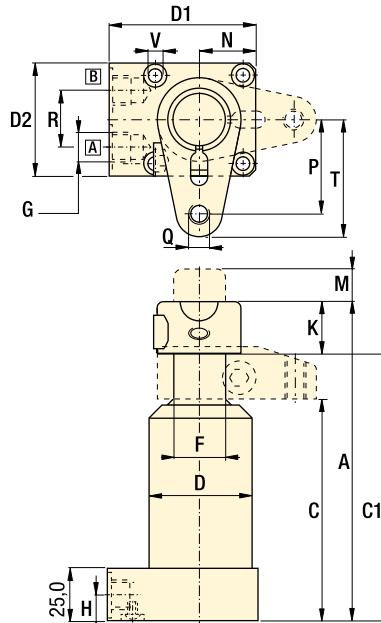

**Force: 2,1 - 33,8 kN**

**Stroke: 16,5 - 32,6 mm**

**Pressure: 35 - 350 bar**

- E** Cilindros giratorios
- F** Vérins de bridage pivotants
- D** Schwenkspannzylinder

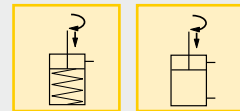

**Options**

**Clamp arms**  
32 ▶

**Work supports**  
43 ▶

**Collet-Lok® swing cylinders**  
12 ▶

**Accessories**  
86 ▶

**Important**

30, 45, and 60 degree rotations are available upon request. Add -30, -45 or -60 to end of standard model number to order directly from Enerpac. To order rotation limiter separately, see page 32.

Custom cylinders including longer stroke lengths are available on request.

In case there is a risk of machining coolants and debris being inhaled via the breather vent, it is recommended to pipe this port to an area outside the fixture that is protected from machining coolants and debris.

Do not exceed maximum flow rates.

N	P	Q	R	S	T	U	V	X	Y	Z	Right turning models
											kg
											Single acting ▼
15,5	24,5	M6 x 1	-	21,0	31,0	40,1	5,8	18,1	30°	60°	0,5 <b>SLRS-22</b>
19,1	40,0	M8 x 1,25	-	41,0	48,0	50,0	6,9	14,4	30°	60°	1,1 <b>SLRS-52</b>
26,4	45,1	M10 x 1,5	25,9	23,7	56,1	41,9	6,6	28,7	-	-	2,0 <b>SLRS-92</b>
25,1	51,4	0,375-16 UNC	-	52,0	62,0	63,5	8,9	18,2	30°	60°	1,6 <b>SLRS-121</b>
34,4	55,2	M12 x 1,75	25,9	29,1	70,4	55,1	8,4	35,1	-	-	3,5 <b>SLRS-202</b>
43,4	67,9	M16 x 2	26,0	34,4	82,9	70,0	10,8	41,6	-	-	5,5 <b>SLRS-352</b>
											Double acting ▼
15,5	24,5	M6 x 1	-	21,0	30,9	41,9	5,7	18,1	30°	60°	0,5 <b>SLRD-22</b>
19,1	40,0	M8 x 1,25	-	41,0	47,9	50,0	6,8	14,4	30°	60°	1,1 <b>SLRD-52</b>
26,4	45,1	M10 x 1,5	26,0	23,7	56,0	42,0	6,5	28,6	-	-	2,0 <b>SLRD-92</b>
25,1	51,4	0,375-16 UNC	-	52,0	61,8	63,5	8,8	18,2	30°	60°	1,6 <b>SLRD-121</b>
34,4	55,2	M12 x 1,75	26,0	29,1	70,2	55,0	8,5	35,1	-	-	3,5 <b>SLRD-202</b>
43,4	67,9	M16 x 2	26,0	34,4	82,9	70,0	10,8	41,6	-	-	5,5 <b>SLRD-352</b>



# Swing clamps - Threaded body models

Shown: STRD-52, STRD-202



## ST series

Enerpac threaded body swing clamps are threaded directly into the fixture.

The cylinder height is adjusted to the appropriate height, and then locked in place using a jam nut (□36).

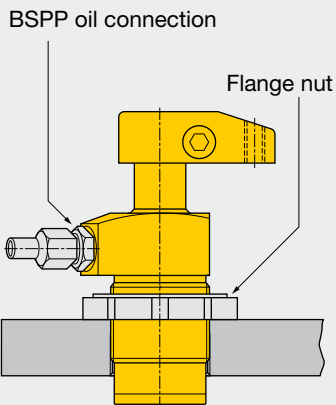

Threaded body swing clamps allow the clamp to be buried in the fixture to minimize the required area, while the height remains adjustable.



## Cylinders can be threaded directly into fixture

...can be secured at any height

- Body thread for precise cylinder height positioning
- Threaded port connection
- Easy installation and removal
- Greatest flexibility in fixture design
- 30, 45 and 60 degree swing angles available on request

## Product selection

Clamping force <sup>1)</sup>	Stroke		Left turning 90°	Right turning 90°	Cylinder effective area		Oil capacity		Max. oil flow <sup>1)</sup>	Standard clamp arm
	kN	Clamp			mm	cm <sup>2</sup>	cm <sup>3</sup>	cm <sup>2</sup>		
					Clamp	Un-clamp	Clamp	Un-clamp	l/min	Sold separately □32 ▶
<b>▼ Single acting</b>										
Model number <sup>2)</sup>										
2,1	8	16,5	<b>STLS-22</b>	<b>STRS-22</b>	0,77	–	1,31	–	0,2	<b>CAS-22</b>
4,9	10	22,6	<b>STLS-52</b>	<b>STRS-52</b>	1,81	–	4,10	–	0,4	<b>CAS-52</b>
8,0	12	23,0	<b>STLS-92</b>	<b>STRS-92</b>	3,16	–	6,88	–	1,0	<b>CAS-92</b>
10,7	13	27,7	<b>STLS-121</b>	<b>STRS-121</b>	4,06	–	11,47	–	1,6	<b>CAS-121</b>
17,4	14	29,5	<b>STLS-202</b>	<b>STRS-202</b>	7,10	–	19,99	–	2,3	<b>CAS-202</b>
33,1	16	32,6	<b>STLS-352</b>	<b>STRS-352</b>	12,39	–	37,20	–	3,9	<b>CAS-352</b>
<b>▼ Double acting</b>										
Model number <sup>2)</sup>										
2,2	8	16,5	<b>STLD-22</b>	<b>STRD-22</b>	0,77	1,55	1,31	2,46	0,2	<b>CAS-22</b>
5,6	10	22,6	<b>STLD-52</b>	<b>STRD-52</b>	1,81	3,81	4,10	8,52	0,4	<b>CAS-52</b>
9,0	12	23,0	<b>STLD-92</b>	<b>STRD-92</b>	3,16	8,06	6,88	17,70	1,0	<b>CAS-92</b>
11,6	13	27,7	<b>STLD-121</b>	<b>STRD-121</b>	4,06	7,94	11,47	22,94	1,6	<b>CAS-121</b>
18,7	14	29,5	<b>STLD-202</b>	<b>STRD-202</b>	7,10	15,16	19,99	42,61	2,3	<b>CAS-202</b>
33,8	16	32,6	<b>STLD-352</b>	<b>STRD-352</b>	12,39	23,74	37,20	71,28	3,9	<b>CAS-352</b>

<sup>1)</sup> With standard clamp arm. Clamp arms are sold separately (□32). Clamping forces for single-acting models are reduced in order to overcome return spring force.

<sup>2)</sup> For models with straight plunger movement, replace L or R with S.



**Note:** Call Enerpac to order models with SAE port connections.

## Dimensions in mm [ □32 ]

Left turning models	A	B	C	C1	C2	D	D1	D2	F	G	H	J1
						∅			∅			
<b>▼ Single acting</b>												
<b>STLS-22</b>	112	59	26,4	43,0	24,9	M28 x 1,5	39,4	33	10	G1/8"	10	–
<b>STLS-52</b>	135	69	27,4	50,1	24,9	M35 x 1,5	47,5	38	16	G1/8"	10	–
<b>STLS-92</b>	143	80	33,5	56,4	30,2	M48 x 1,5	62,5	48	25	G1/4"	13	43
<b>STLS-121</b>	171	86	27,7	55,3	25,4	1.875-16 UNF	60,5	51	22	SAE#4	10	–
<b>STLS-202</b>	165	93	35,6	65,0	32,0	M65 x 1,5	75,9	65	32	G1/4"	13	55
<b>STLS-352</b>	186	105	35,1	67,5	32,0	M80 x 2	88,4	80	38	G1/4"	13	65
<b>▼ Double acting</b>												
<b>STLD-22</b>	112	59	26,4	43,0	24,9	M28 x 1,5	39,4	33	10	G1/8"	10	53
<b>STLD-52</b>	135	69	27,4	50,1	24,9	M35 x 1,5	47,5	38	16	G1/8"	10	66
<b>STLD-92</b>	143	80	33,5	56,4	30,2	M48 x 1,5	62,5	48	25	G1/4"	13	43
<b>STLD-121</b>	171	86	27,7	55,3	25,4	1.875-16 UNF	60,5	51	22	SAE#4	10	86
<b>STLD-202</b>	165	93	35,6	65,0	32,0	M65 x 1,5	75,9	65	32	G1/4"	13	55
<b>STLD-352</b>	186	105	35,1	67,5	32,0	M80 x 2	88,4	80	38	G1/4"	13	65

**NOTE:** dimensions shown with standard clamp arm.

**Accessory Chart**

Model Nos.		Mounting flange	Flange nut
Left turning	Right turning		
	90° 	Sold Separately ☐ 87 ▶	Sold Separately ☐ 86 ▶

▼ **Single acting**

STLS-22	STRS-22	MF-282	FN-282
STLS-52	STRS-52	MF-352	FN-352
STLS-92	STRS-92	MF-482	FN-482
STLS-121	STRS-121	MF-481	FN-481
STLS-202	STRS-202	MF-652	FN-652
STLS-352	STRS-352	MF-802	FN-802

▼ **Double acting**

STLD-22	STRD-22	MF-282	FN-282
STLD-52	STRD-52	MF-352	FN-352
STLD-92	STRD-92	MF-482	FN-482
STLD-121	STRD-121	MF-481	FN-481
STLD-202	STRD-202	MF-652	FN-652
STLD-352	STRD-352	MF-802	FN-802

-22, 52, 121

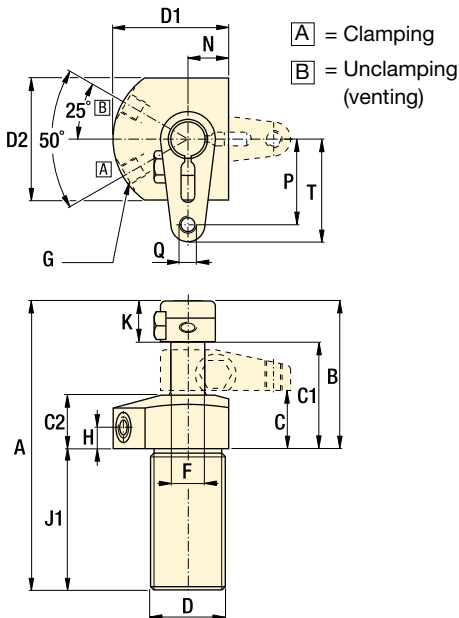

-92, 202, 352

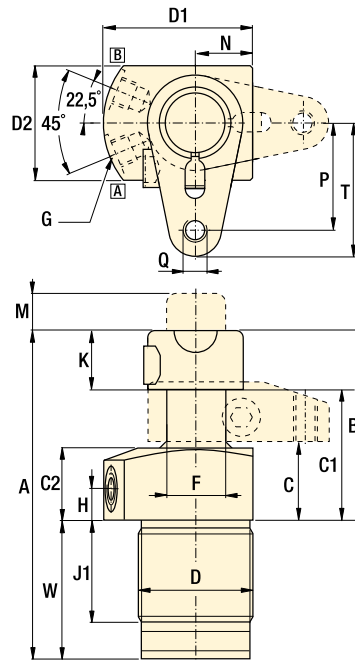

K	M	N	P	Q	T	W	Y	Z		Right turning models
<b>Single acting ▼</b>										
16	-	15,5	24	M6 x 1	31	-	25°	50°	0,5	<b>STRS-22</b>
19	-	19,1	40	M8 x 1,25	48	-	25°	50°	1,1	<b>STRS-52</b>
25	15,5	23,9	45	M10 x 1,5	56	63,0	22,5°	45°	2,0	<b>STRS-92</b>
30	-	25,4	51	0.375-16 UNC	62	-	25°	50°	1,6	<b>STRS-121</b>
30	23,6	32,5	55	M12 x 1,75	70	71,9	22,5°	45°	3,2	<b>STRS-202</b>
40	27,9	39,9	68	M16 x 2	83	81,5	22,5°	45°	5,5	<b>STRS-352</b>
<b>Double acting ▼</b>										
16	-	15,5	24	M6 x 1	31	-	25°	50°	0,5	<b>STRD-22</b>
19	-	19,1	40	M8 x 1,25	48	-	25°	50°	1,1	<b>STRD-52</b>
25	-	23,9	45	M10 x 1,5	56	63,0	22,5°	45°	2,0	<b>STRD-92</b>
30	-	25,4	51	0.375-16 UNC	62	-	25°	50°	1,6	<b>STRD-121</b>
30	-	32,5	55	M12 x 1,75	70	71,9	22,5°	45°	3,5	<b>STRD-202</b>
40	-	39,9	68	M16 x 2	83	81,5	22,5°	45°	5,5	<b>STRD-352</b>

Force: 2,1 - 33,8 kN

Stroke: 16,5 - 32,6 mm

Pressure: 35 - 350 bar

- E** Cilindros giratorios
- F** Vérins de bridage pivotants
- D** Schwenkspannzylinder

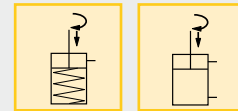

**Options**

**Clamp arms**  
☐ 32 ▶ 

**Work supports**  
☐ 43 ▶ 

**Collet-Lok® swing cylinders**  
☐ 12 ▶ 

**Accessories**  
☐ 86 ▶ 

**Important**

30, 45, and 60 degree rotations are available upon request. Add -30, -45 or -60 to end of standard model number to order directly from Enerpac. To order rotation limiter separately, see page 32.

Custom cylinders including longer stroke lengths are available on request.

In case there is a risk of machining coolants and debris being inhaled via the breather vent, it is recommended to pipe this port to an area outside the fixture that is protected from machining coolants and debris.

Do not exceed maximum flow rates.

# Swing clamps - Cartridge models

Shown: SCRD-122, SCRD-52



## SC series

Enerpac cartridge swing clamps are designed for integrated manifold mounting. This eliminates the need for fittings and tubing on the fixture.

Cartridge swing clamps simplify mounting and optimize clamping effectiveness.

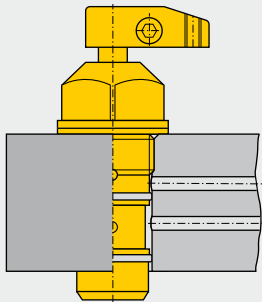

Hydraulic fixture with components on two faces for more efficient production.



## Eliminates the need for tubing and fittings

- Minimal space required on fixture
- Can be completely recessed in fixture
- External plumbing not required
- Allows close positioning of adjoining units
- 30, 45 and 60 degree swing angles available on request

Enerpac compact design cartridge model swing clamps used in conjunction with a cartridge model work support in a typical clamping application.

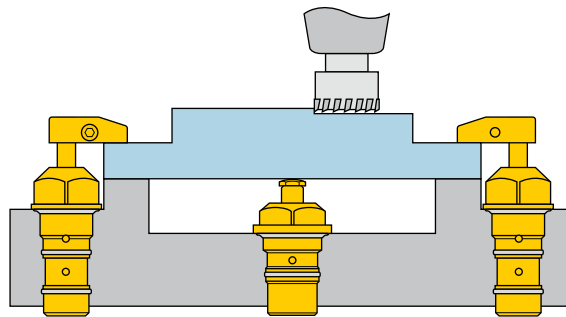

## Product selection

Clamping force <sup>1)</sup>	Stroke		Left turning	Right turning	Cylinder effective area		Oil capacity		Max. oil flow <sup>1)</sup>	Standard clamp arm
	kN	mm			cm <sup>2</sup>	cm <sup>3</sup>				
	Clamp	Total		90°	Clamp	Un-clamp	Clamp	Un-clamp	l/min	Sold separately □ 32 ▶
<b>▼ Single acting</b>										
Model number <sup>2)</sup>										
2,1	8,1	16,8	<b>SCLS-22</b>	<b>SCRS-22</b>	0,77	-	1,31	-	0,2	<b>CAS-22</b>
4,9	9,9	22,6	<b>SCLS-52</b>	<b>SCRS-52</b>	1,81	-	4,09	-	0,4	<b>CAS-52</b>
10,7	12,7	27,7	<b>SCLS-122</b>	<b>SCRS-122</b>	4,06	-	11,47	-	1,6	<b>CAS-121</b>
<b>▼ Double acting</b>										
Model number <sup>2)</sup>										
2,2	8,1	16,8	<b>SCLD-22</b>	<b>SCRD-22</b>	0,77	1,55	1,31	2,49	0,2	<b>CAS-22</b>
5,6	9,9	22,6	<b>SCLD-52</b>	<b>SCRD-52</b>	1,81	3,81	4,09	8,52	0,4	<b>CAS-52</b>
11,6	12,7	27,7	<b>SCLD-122</b>	<b>SCRD-122</b>	4,06	7,94	11,47	22,94	1,6	<b>CAS-121</b>

<sup>1)</sup> With standard clamp arm. Clamp arms are sold separately (□32). Clamping forces for single-acting models are reduced in order to overcome return spring force.

<sup>2)</sup> For models with straight plunger movement, replace L or R with S.

## Dimensions in mm [ ]

Left turning models	A	B	C	C1	C2	D1	D2	E	F
						∅	∅	hexagon	
<b>▼ Single acting</b>									
<b>SCLS-22</b>	112,0	57,4	24,9	41,4	23,9	38,4	25,4	34,8	9,9
<b>SCLS-52</b>	135,4	79,8	37,8	60,7	35,3	56,6	34,8	50,5	16,0
<b>SCLS-122</b>	171,5	96,5	38,6	66,3	36,3	75,9	57,2	69,6	22,1
<b>▼ Double acting</b>									
<b>SCLD-22</b>	112,0	57,4	24,9	41,4	23,9	38,4	25,4	34,8	9,9
<b>SCLD-52</b>	135,4	79,8	37,8	60,7	35,3	56,6	34,8	50,5	16,0
<b>SCLD-122</b>	171,5	96,5	38,6	66,3	36,3	75,9	57,2	69,6	22,1

NOTE: dimensions shown with standard clamp arm.

**Installation dimensions in mm**

**-22 models**

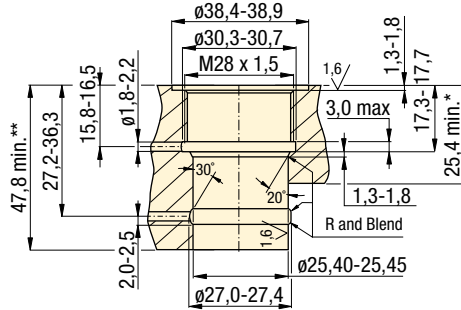

**-52 models**

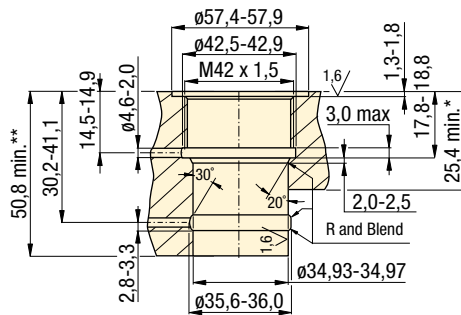

**-122 models**

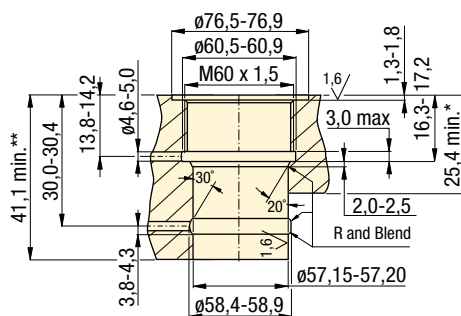

\* Minimum plate height for single-acting models.

\*\* Minimum plate height for double-acting models.

**-22, 52, 122 models**

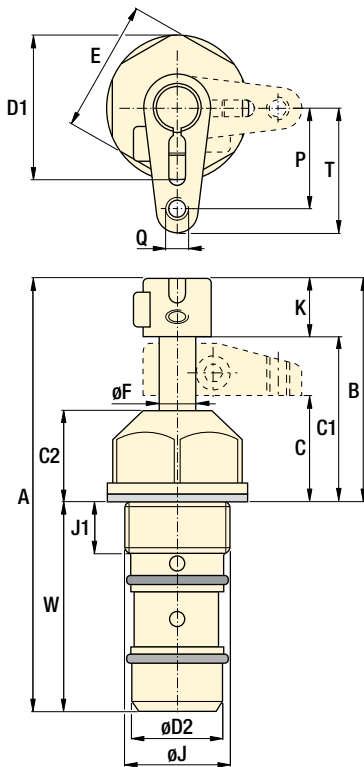

**Force: 2,1 - 11,6 kN**

**Stroke: 16,8 - 27,7 mm**

**Pressure: 35 - 350 bar**

- E** Cilindros giratorios
- F** Vérins de bridage pivotants
- D** Schwenkspannzylinder

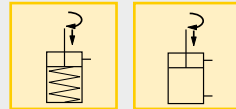

**Options**

**Clamp arms**

☐ 32 ▶

**Work supports**

☐ 43 ▶

**Collet-Lok® swing cylinders**

☐ 12 ▶

**Accessories**

☐ 86 ▼

**Sequence valves**

☐ 152 ▶

**⚠ Important**

30, 45, and 60 degree rotations are available upon request. Add -30, -45 or -60 to end of standard model number to order directly from Enerpac. To order rotation limiter separately, see page 32.

Custom cylinders including longer stroke lengths are available on request.

In case there is a risk of machining coolants and debris being inhaled via the breather vent, it is recommended to pipe this port to an area outside the fixture that is protected from machining coolants and debris.

Do not exceed maximum flow rates.

	J	J1	K	P	Q	T	W		Right turning models
	Ø							kg	
<b>Single acting ▼</b>									
	M28 x 1,5	12,7	16,0	24,6	M6 x 1	31,0	54,6	0,5	<b>SCRS-22</b>
	M42 x 1,5	13,7	19,3	40,1	M8 x 1,25	48,0	55,6	0,9	<b>SCRS-52</b>
	M60 x 1,5	13,2	30,5	51,6	.375-16 UNC	62,0	74,9	2,5	<b>SCRS-122</b>
<b>Double acting ▼</b>									
	M28 x 1,5	12,7	16,0	24,6	M6 x 1	31,0	54,6	0,5	<b>SCRD-22</b>
	M42 x 1,5	13,7	19,3	40,1	M8 x 1,25	48,0	55,6	0,9	<b>SCRD-52</b>
	M60 x 1,5	13,2	30,5	51,6	.375-16 UNC	62,0	74,9	2,5	<b>SCRD-122</b>

# Clamp arms for swing clamps

Shown: CAS-122, CAL-122



Collet-Lok® products

Swing clamps

## Clamp Arms

Enerpac's patented clamp arm design attaches to the hydraulic swing cylinder, allowing parts to be clamped at various distances from the hydraulic cylinder. Clamp arms are available in a variety of lengths, or you can use custom machining dimensions to create your own clamp arm configuration.

Ordering rotation limiting spacers

### BUILD YOUR PART NUMBER:

SP	186
Clamp force	Angle
02 = 2,2 kN	30
05 = 5,6 kN	45
09 = 9,0 kN	60
12 = 11,6 kN	
20 = 18,7 kN	
35 = 33,8 kN	

### Example:

SP-12 45-186 converts a 11,6 kN swing cylinder to 45 degree rotation.

The addition of this spacer requires minor disassembly of the clamp. If you are uncomfortable doing this, please contact an authorized Enerpac Service Center.

## Patented Design

- Easy and precise location of the clamp arm in any position
- Arm can be easily installed and fastened while the cylinder is mounted in the fixture to allow exact arm positioning
- Vise not required for fastening arms.

## Pressure vs clamping force

The use of different length clamp arms requires reduction in applied pressure and resulting clamp force. The charts below show this relationship.

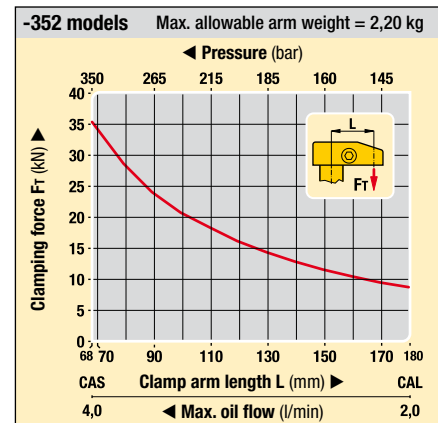
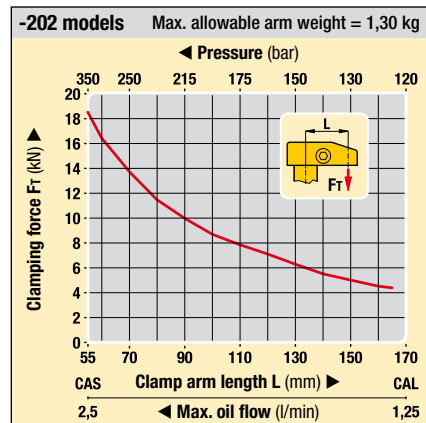
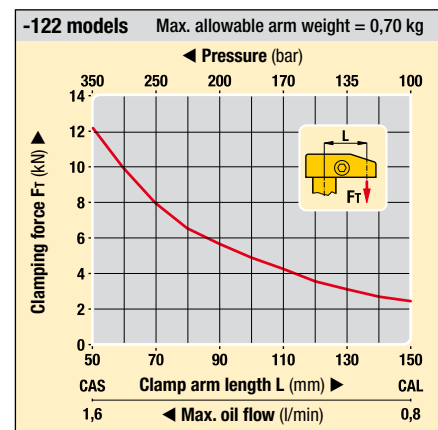
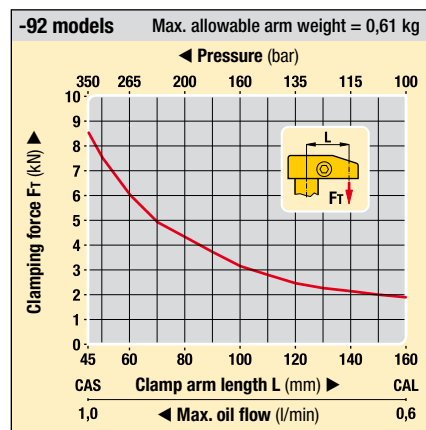
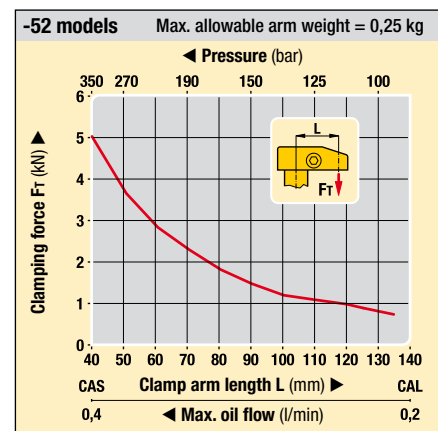
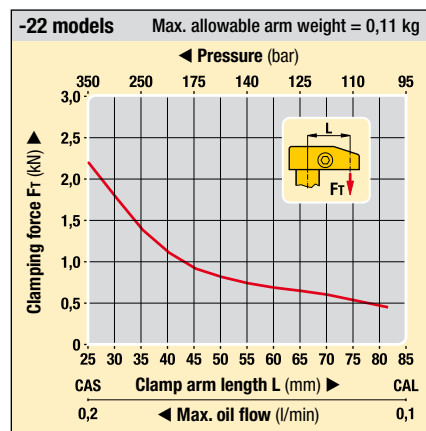

CAS models Standard clamp arms

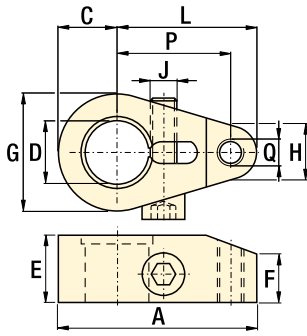

CAL models Long clamp arms

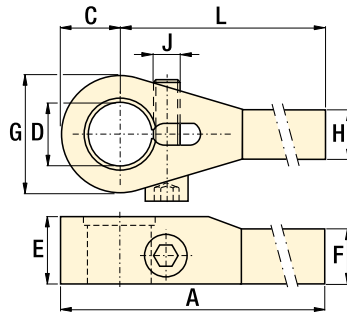

Custom design (for SU, SL, ST and SC models only)

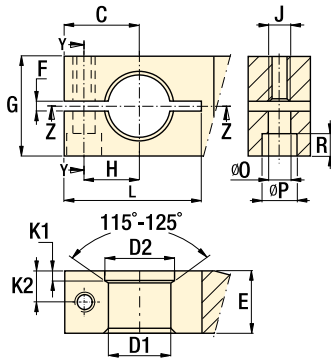

Dimensions in mm [ ]

Clamp force kN	Model number	A	C	D	E	F	G	H	J	L	P	Q	kg
2,2	CAS-22	41	9,7	9,98-10,03	16	10	19	13	M6 x 1	31	25	M6 x 1	0,1
5,6	CAS-52	61	12,7	16,00-16,03	19	11	25	16	M8 x 1	48	40	M8 x 1,25	0,4
9,0	CAS-92	76	20,1	25,02-25,04	25	16	40	22	M10 x 1,25	56	45	M10 x 1,5	0,3
11,6	CAS-121	80	17,8	22,25-22,28	30	16	36	21	.375-24 UNF	62	51	.375-16 UN	0,5
18,7	CAS-202	94	24,1	32,00-32,05	30	21	48	30	M12 x 1,25	70	55	M12 x 1,75	0,5
33,8	CAS-352	118	35,1	38,02-38,05	40	30	70	30	M16 x 1,5	83	68	M16 x 2	1,4
2,2	CAL-22	92	9,7	9,98-10,03	16	11	19	11	M6 x 1	83	-	-	0,1
5,6	CAL-52	148	12,7	16,00-16,03	19	11	25	14	M8 x 1	135	-	-	0,5
9,0	CAL-92	180	20,1	25,02-25,04	25	16	40	18	M10 x 1,25	160	-	-	0,6
11,6	CAL-122	179	17,8	22,25-22,28	30	16	36	19	M10 x 1,5	162	-	-	0,7
18,7	CAL-202	202	24,1	32,00-32,05	30	21	48	25	M12 x 1,25	178	-	-	0,7
33,8	CAL-352	215	35,1	38,02-38,05	40	34	70	30	M16 x 1,5	180	-	-	1,9

Clamp force kN	C	D1 <sup>1)</sup>	D2	E	F	G	H	J	K1	K2	L	O	P	R
2,2	15,5	10,00-10,02	12,58-12,62	16	1,5-3,0	20	9,4	M6 x 1	3,1-3,5	8	25-28	7	11	6
5,6	20,1	16,00-16,03	18,47-18,51	19	1,5-3,0	30	13,5	M8 x 1	4,1-4,5	10	35-40	9	14	7
9,0	30,0	25,00-25,03	27,85-27,95	25	1,5-3,0	40	22,1	M10 x 1,25	3,9-4,2	12	55-60	11	17	9
11,6	28,4	22,24-22,27	25,46-25,55	30	1,5-3,0	35	17,8	M10 x 1,5	6,9-7,3	13	52-57	11	17	8
18,7	35,1	32,00-32,04	35,50-35,60	30	1,5-3,0	60	24,9	M12 x 1,25	5,1-5,5	15	62-67	13	19	11
33,8	39,9	38,00-38,04	41,50-41,60	40	1,5-3,0	70	30,0	M16 x 1,5	4,9-5,3	20	80-85	17	25	11

<sup>1)</sup> Surface roughness for D1 should be I,6 micro meters.  
<sup>2)</sup> Not for use with Collet-Lok swing clamps.

Force: 2,2 - 33,8 kN

Pressure: 35 - 350 bar

- Brazos de amarre
- Bras de bridage
- Spannarme

Options

Gauges and accessories

190



Flow control valves

155



Important

**Do not exceed maximum oil flow.**

If flow rates are exceeded, swing cylinder indexing mechanism may be permanently damaged.

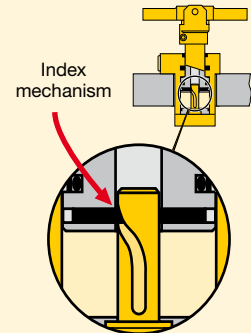

When designing custom clamp arms, the flow rates must be further reduced. This rating should be in proportion to the mass and the center of gravity of the clamp arm.

**Example:**

*If the mass of the arm is twice that of the long arm, flow rates must be reduced by 50%.*

# Pivoting T-Arms for double-acting swing clamps

Shown: CAC-202, CAPT-202; CAC-352, CAPT-352

Collet-Lok® products

Swing clamps



▶ **Clamp arms are used to transmit the force generated by the swing cylinder to the workpiece. The T-arm clamps two workpieces simultaneously with one swing cylinder. Enerpac recommends using the pivoting T-arms with double-acting swing clamps of the SU, SL, ST and SC-series.**

■ *Two workpieces are clamped simultaneously with one double-acting swing cylinder by using the Enerpac pivoting T-arm.*



## Clamping two workpieces with one cylinder

...quick and precise clamp arm positioning

- Easy and precise location of the clamp arm in any position
- Arm can be easily installed and fastened while the cylinder is mounted in the fixture to allow exact arm positioning
- Vise not required for fastening arms or threaded into the fixture
- CAC-92, -202 and -352 are only to be used on double-acting cylinders.

### **i** Allowable flow vs arm length

The distribution of the clamp arm force is based upon the length of the T-arm as measured from the pivoting point.

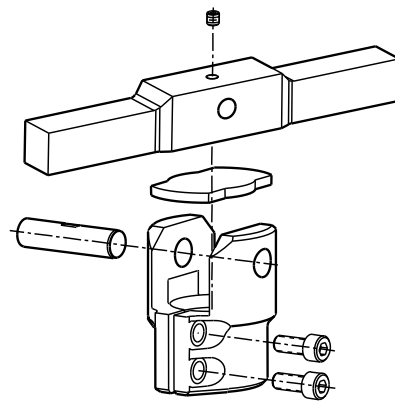

### **!** Important

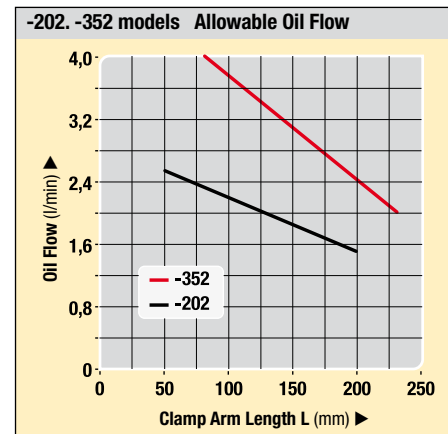
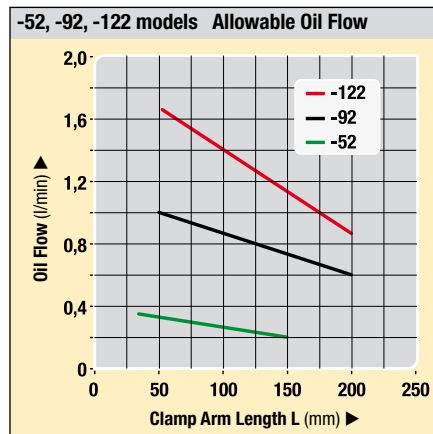
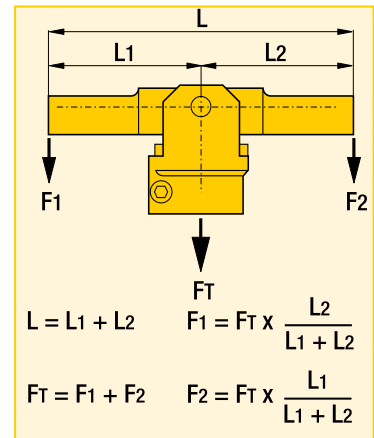

Shown: CAC-202

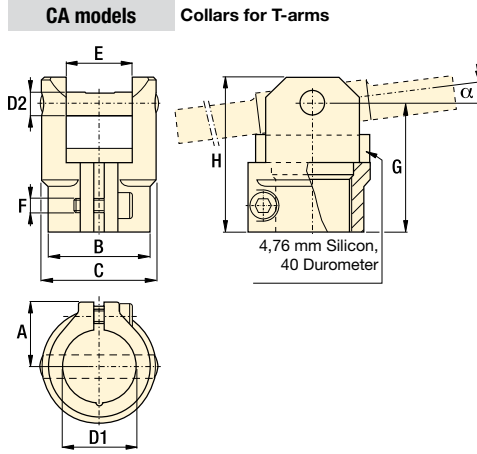

**Collars - Dimensions** in mm [  $\varnothing$  ]

Clamp. force kN	Model number	Max. tilt angle $\alpha$	A	B	C	D1	D2	E	F	G	H	kg
5,6	<b>CAC-52</b>	20°	16,5	24,2	28,0	16,0	6,0	6,0	M4 x 0,7	32,0	40,0	0,1
9,0	<b>CAC-92</b>	14°	22,0	34,6	39,0	25,0	8,0	8,0	M5 x 0,8	43,4	52,6	0,2
11,6	<b>CAC-122</b>	14°	22,0	34,6	39,0	22,3	8,0	8,0	M5 x 0,8	43,4	52,6	0,2
18,7	<b>CAC-202</b>	10°	27,2	46,6	54,5	32,0	10,0	10,7	M6 x 1	51,2	63,0	0,4
33,8	<b>CAC-352</b>	10°	34,0	54,6	63,0	38,0	14,0	14,0	M8 x 1,25	63,4	79,0	0,8

Shown: CAPT-202

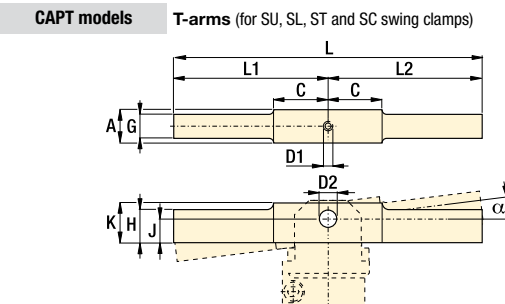

**T-arms - Dimensions** in mm [  $\varnothing$  ]

Clamp. force kN	Model number	A	C	D1*	D2	G	H	J	K	L	L1	L2	kg
5,6	<b>CAPT-52</b>	15,5	25,4	M3 x 0,5	6,00-6,10	12,7	12,7	9,9	19,1	152,4	76,2	76,2	0,3
9,0	<b>CAPT-92</b>	22,1	38,1	M4 x 0,7	8,00-8,10	18,3	18,3	15	22,1	203,2	101,6	101,6	0,7
11,6	<b>CAPT-122</b>	22,1	38,1	M4 x 0,7	8,00-8,10	18,3	18,3	15	22,1	203,2	101,6	101,6	0,7
18,7	<b>CAPT-202</b>	28,4	31,8	M6 x 1	10,00-10,10	22,1	22,1	16,3	28,7	203,2	101,6	101,6	1,0
33,8	<b>CAPT-352</b>	34,8	25,1	M6 x 1	14,00-14,10	30,0	30,0	18,5	34,8	228,6	114,3	114,3	1,8

\* Note: D1 equals set screw thread size. Set screw must be long enough to secure the pivot pin.

**Installation dimensions** in mm [  $\varnothing$  ]

Clamping force kN	T-arm model	SU-series C	SU-L-series C	SL-series C	ST-series C	SC-series C
5,6	-52	73,7	-	139,7	73,7	81,0
9,0	-92	79,5	99,3	155,7	84,3	-
11,6	-122	90,2	108,7	176,0	90,2	98,3
18,7	-202	90,7	-	177,5	90,7	-
33,8	-352	102,6	119,1	199,1	100,8	-

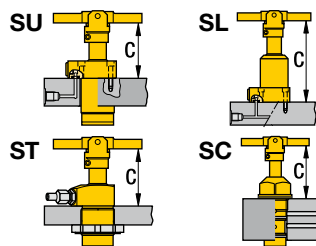

**Force: 5,6 - 33,8 kN**

**Pressure: 35 - 350 bar**

- E** Brazos de amarre
- F** Bras de bridage
- D** Spannarme

**Options**

**Gauges and accessories**  

 190 ▶

**Flow control valves**  

 155 ▶

**Download CAD files from enerpacwh.com**

**30, 45, and 60 degree rotations are available upon request.**

**Important**

**For high cycle applications use double-acting cylinders.**

**Do not exceed maximum oil flow.**

If flow rates are exceeded, swing cylinder indexing mechanism may be permanently damaged.

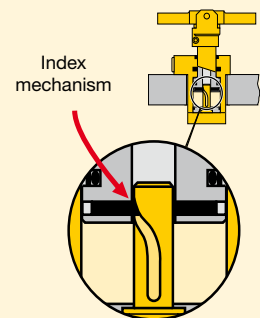

When designing custom clamp arms, the flow rates must be further reduced. This rating should be in proportion to the mass and the center of gravity of the clamp arm.

**Example:**

If the mass of the arm is twice that of the long arm, flow rates must be reduced by 50%.



# Upreach clamp arms for swing clamps

Shown: CAU-352, CAU-122, CAU-22



**Enerpac's patented upreach clamp arm design attaches to the hydraulic swing cylinder, allowing parts to be clamped at various distances from the hydraulic cylinder. Clamp arms are available in an extended length which can be machined to fit your unique requirements.**

## Important

### Do not exceed maximum oil flow.

If flow rates are exceeded, swing cylinder indexing mechanism may be permanently damaged.

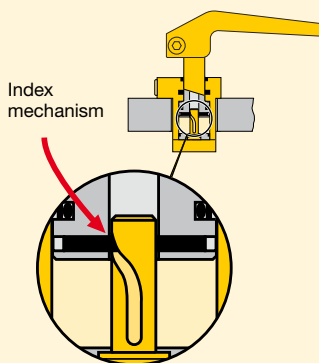

When designing custom clamp arms, the flow rates must be further reduced. This rating should be in proportion to the mass and the center of gravity of the clamp arm.

### Example:

If the mass of the arm is twice that of the long arm, flow rates must be reduced by 50%.

## Patented Design

- Upreach design allows more flexible part clamping
- Arm can be easily installed and fastened while the cylinder is mounted in the fixture to allow exact arm positioning
- Vise not required for fastening arms
- Arm length can be cut to desired size
- Angled arm with minimal deflection achieves maximum workpiece contact.

## Pressure vs clamping force

The use of different length clamp arms requires reduction in applied pressure and resulting clamp force. The charts below show this relationship.

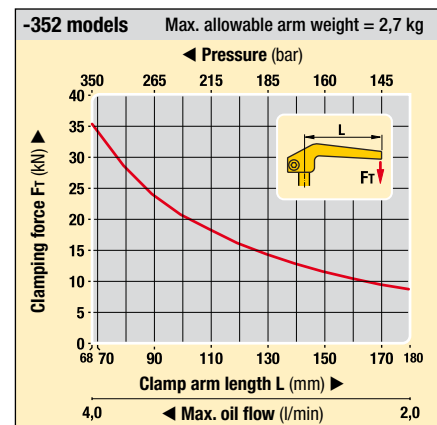
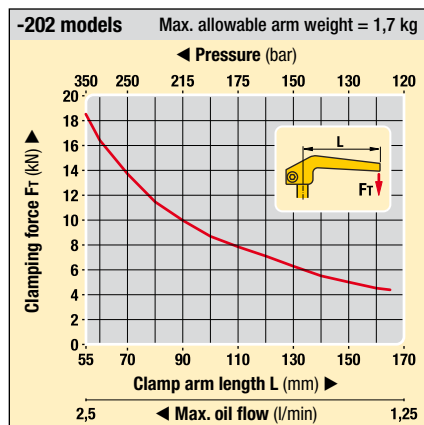
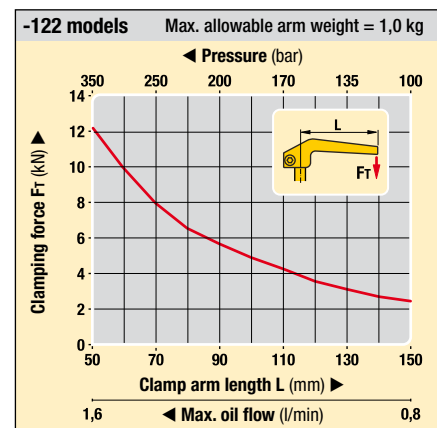
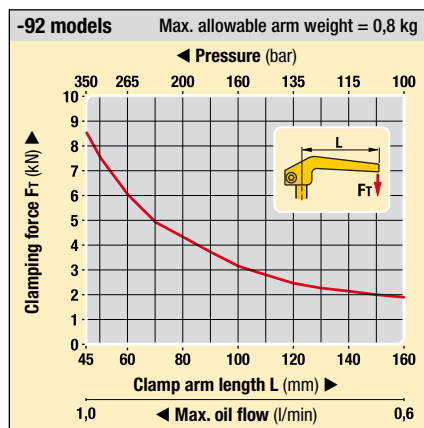
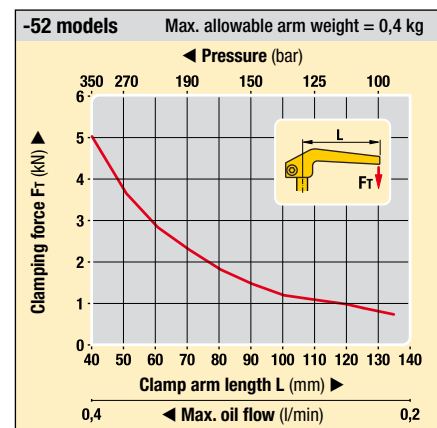
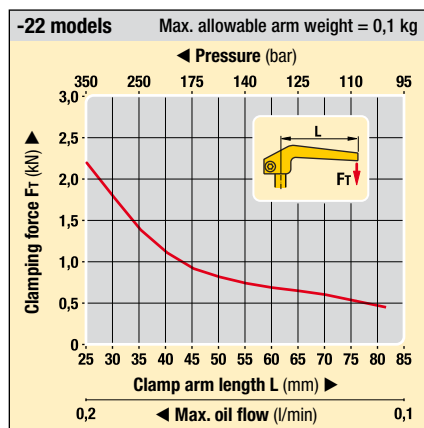

**Angled arms use deflection to improve clamping**

**Angled arms**

Tip engages part first and contact increases as clamping force is applied.

Eliminates “push” effect caused by straight arms deflecting under load.

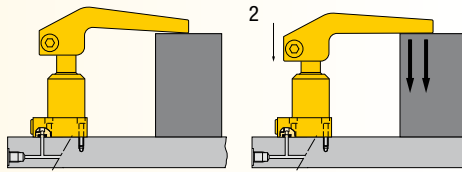

**Straight Arms**

Great for most applications, but standard deflection can cause part movement and lower the true clamping force.

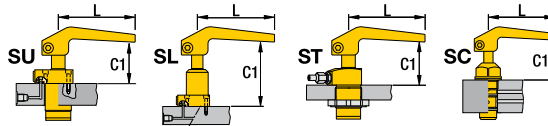
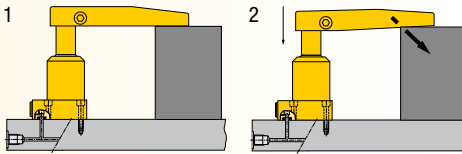

**Installation dimensions in mm [  $\pm 0.1$  ]**

Model number	Clamp force	L	SU-Series C1	SL-Series C1	ST-Series C1	SC-Series C1
<b>▼ Stock length dimensions</b>						
CAU-22	0,44	82,5	56,6	109,7	56,6	53,1
CAU-52	0,89	134,8	71,6	137,7	71,6	78,7
CAU-92	2,00	160,0	73,6	149,6	78,7	-
CAU-122	2,22	161,1	83,5	169,4	83,6	91,7
CAU-202	4,45	177,5	88,1	175,3	95,3	-
CAU-352	8,45	180,0	99,0	192,0	106,2	-
<b>▼ Minimum length dimensions</b>						
CAU-22	2,22	25,0	59,7	112,8	59,7	56,1
CAU-52	5,56	40,0	76,7	142,7	76,7	83,8
CAU-92	9,01	45,0	79,9	155,7	84,8	-
CAU-122	11,57	50,8	89,4	175,3	89,4	97,5
CAU-202	18,68	55,0	94,5	181,6	101,6	-
CAU-352	33,81	68,0	106,9	199,9	114,1	-

**CAU models Upreach clamp arms**

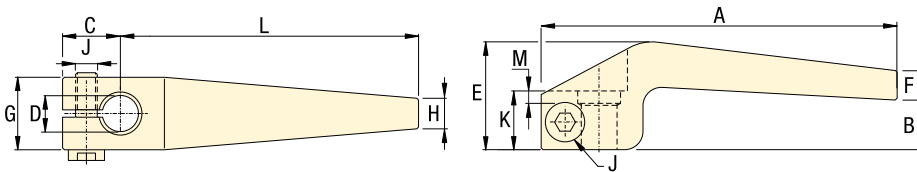

**Dimensions in mm [  $\pm 0.1$  ]**

Model number	A	B	B	C	D	E	F	F	G	H	H	J	K	L	L	M	kg
		Std.	Min.				Std.	Min.		Std.	Min.			Std.	Min.		
CAU-22	98,5	13,7	16,8	16,0	9,98-10,01	29,7	8,1	13,7	20,0	8,4	20,8	M6 x 1	16,3	82,5	25,0	1,0	0,1
CAU-52	155,0	21,6	26,7	20,0	16,00-16,03	41,9	6,6	14,5	30,0	11,9	31,8	M6 x 1	19,1	135,0	40,0	1,3	0,4
CAU-92	190,0	23,6	29,7	30,0	25,02-25,04	48,0	10,9	19,3	40,0	14,5	40,9	M8 x 1,25	24,9	160,0	45,0	2,3	0,8
CAU-122	190,0	28,2	34,0	28,5	22,25-22,28	57,2	12,7	29,2	38,1	16,5	39,6	M10 x 1,5	30,0	161,5	50,8	3,8	1,0
CAU-202	212,5	32,3	38,6	35,0	32,00-32,03	61,2	13,2	24,4	60,0	17,3	54,4	M10 x 1,5	30,0	177,5	55,0	2,8	1,7
CAU-352	220,0	41,1	49,0	40,0	38,02-38,05	79,8	18,8	34,3	66,0	15,7	54,1	M10 x 1,5	40,1	180,0	68,0	1,8	2,7

Refer to clamping force charts on page 36.  
Never cut shorter than indicated minimum length.

Force: 0,4 - 33,8 kN

Pressure: 35 - 350 bar

- E** Brazos de amarre
- F** Bras de bridage
- D** Spannarme

**Options**

Sequence valves  [152](#)

Flow control valves  [155](#)

Download CAD files from [enerpacwh.com](http://enerpacwh.com) 

Shown: SC-3, SC-1



## SC series

These swing clamps rotate 90° as they begin their stroke, continuing without rotation for the final clamping stroke. Cylinders can be changed to left swing, right swing, or pull applications by loosening the side plug and then rotating the plunger to a desired position.

The SC-1 and SC-3 include a retract spring for single-acting operation. Both cylinders can be operated as double-acting cylinders by connecting a retract line to the vent port.

## Changeable swing function

...with 360° fully adjustable clamp arm

- Changeable swing function: clamp arm movement can be adjusted to left or right swing, or straight pull function
- 88-92° clamp arm swing arc
- Easy installation: built-in mountings and brackets
- Compact design for use in limited space applications
- Easy and precise locating of arm for clamp positioning
- Single or double-acting cylinders to suit variety of hydraulic requirements.

Force: 2,2 - 9,6 kN

Stroke: 19,1 - 38,1 mm

Pressure: 138 - 207 bar

- Ⓔ Cilindros giratorios
- Ⓕ Vérins de bridage pivotants
- Ⓖ Schwenkspannzylinder

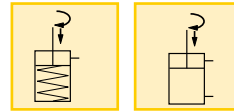

Arm length mm	Max. pressure bar	Clamping force kN
<b>▼ SC-1</b>		
-	207	11,7
51 <sup>2)</sup>	207	9,6
76	207	8,7
102	207	7,7
127	166	5,3
152	138	3,7
<b>▼ SC-3</b>		
-	207	3,1
25 <sup>2)</sup>	207	2,2
51	138	1,1

## Selection chart

Clamping force <sup>1)</sup>	Stroke		Model number	Cylinder effective area		Oil capacity	
	kN	mm		cm <sup>2</sup>	cm <sup>3</sup>		
9,6	12,7	38,1	SC-1	6,3	11,4	24,1	43,4
2,2	6,4	19,1	SC-3	1,6	2,9	3,0	5,4

<sup>1)</sup> With standard clamp arm (included with cylinder).

**Note:** - Long clamp arms can be fabricated by the user.  
- For long clamp arms, use VFC series flow control valves.

<sup>2)</sup> Standard clamp arm (included).

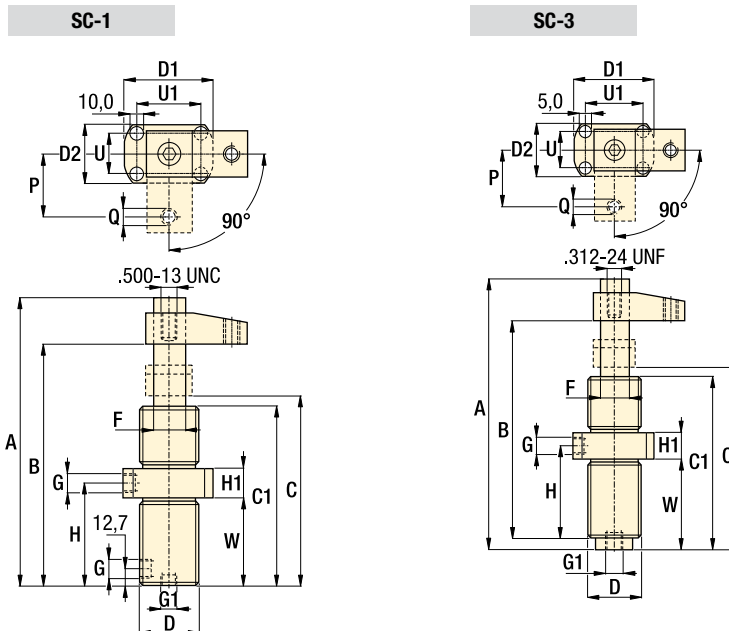

## Product dimensions in mm [ $\pm$ ]

Model number	A	B	C	C1	D	D1	D2	F	G	G1	H	H1	P	Q	U	U1	W	⚖
								Ø	NPT	NPT				UNC				kg
SC-1	226	187	149	146	1.875-16UN	74	48	25	.250-18	.125-27	84,1	22,4	51	.375-16	32,5	52,3	73	2,7
SC-3	134	108	94	88	1.00-12UNF	51	29	13	.125-27	.125-27	54,6	16,0	25	.250-20	19,1	38,1	52	0,9

Force: 6,1 - 19,5 kN

Stroke: 6,4 - 10,9 mm

Pressure: 80 - 170 bar

- E** Cilindros giratorios
- F** Vérins de bridage pivotants
- D** Schwenkspannzylinder

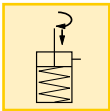

## Adjustable clamping stroke

...turns clockwise or counter-clockwise

- Adjustable bolt in clamp arm for clamping stroke adjustment
- Low profile, ideal for limited space applications
- Quick swing action allows clamp arm to swing free of cutter and reclamp after it has passed
- 94-100° clamp arm swing arc.

ASC-30, -100

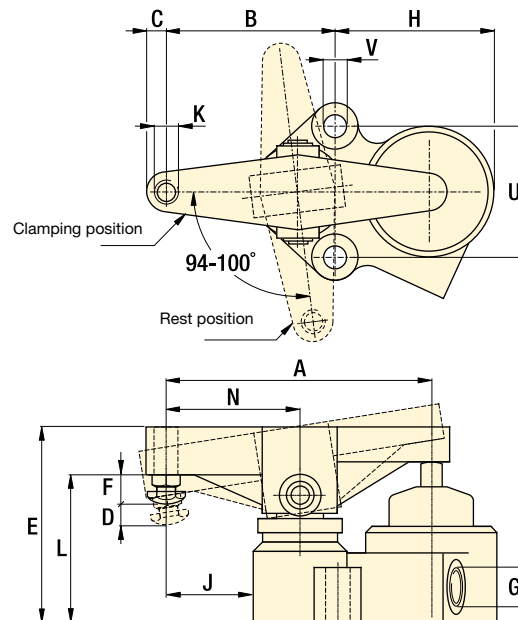

Shown: ASC-30



### ASC series

Clamping arm rotates 97° clockwise or counter-clockwise (requires easily changed rotation spring) to position itself over the workpiece. Then, a vertical plunger exerts an upward thrust on the back end of the swing arm providing a powerful downward pressure to clamp the workpiece.

### Important

For high cycle applications use double-acting cylinders.

View of a machining fixture with ASC-30 clamping cylinders.



## Selection chart

Clamping force	Stroke	Model number	Operating pressure	Cylinder effective area	Oil capacity	Max. oil flow	
kN	mm		bar	cm <sup>2</sup>	cm <sup>3</sup>	l/min	kg
6,1	6,4	<b>ASC-30</b>	80 - 170	3,5	4,9	1,9	2,7
19,5	10,9	<b>ASC-100</b>	80 - 170	11,4	20,0	1,9	8,2

## Product dimensions in mm [ ]

Model number	A	B	C	D	E	F	G	H	J	K	L	N	U	V
							NPT			UN				ø
<b>ASC-30</b>	127,0	85,9	12,7	6,4	88,9	19,1	.125-27	69,9	41,4	.500-13	69,9	63,5	63,5	10,4
<b>ASC-100</b>	177,8	114,3	13,5	10,9	133,4	18,5	.125-27	108	57,2	.500-13	101,6	88,9	88,9	16,0

# Three-position swing cylinder *Application & selection*

Shown: WTR-24



## WTR series

The three position swing cylinder rotates 90° only after the plunger has completely extended. This feature allows the clamp to be mounted beneath the workpiece, where the clamp travels through the part for clamping.

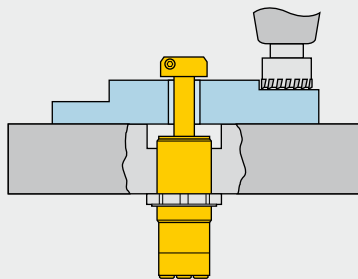

## Unobstructed part loading

- Plunger rotates only when cylinder is fully extended, to minimize obstructions
- Ideal for mounting beneath the fixture, as the clamp does not rotate until the workpiece has been cleared
- Stainless steel body for additional corrosion resistance
- Three port design for fewer hydraulic connections
- Fully threaded body for easy installation
- Standard two sided clamp arm included
- Clamp arm design makes mounting easy.

## Operation sequence

The three position swing cylinder is ideal for parts which have a through hole. The clamp allows completely unobstructed part loading.

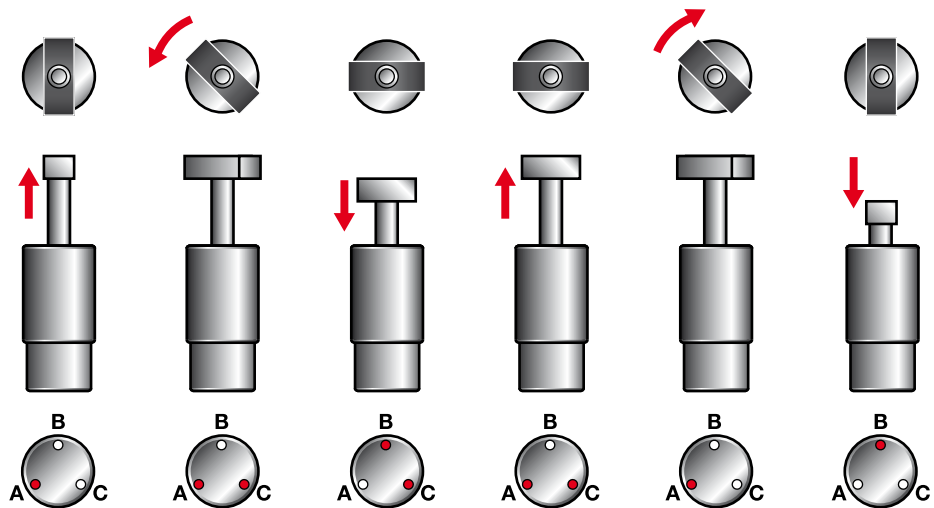

### Step 1

Pressurize port A.  
Plunger extends through workpiece.

### Step 2

Keep port A pressurized.  
Pressurize port C.  
Plunger makes 90° flat rotation.

### Step 3

Keep port C pressurized.  
Pressurize port B.  
Plunger retracts: clamp force is applied.

### Step 4

Keep port C pressurized.  
Pressurize port A.  
Plunger extends: clamp force is released.

### Step 5

Keep port A pressurized.  
Depressurize port C.  
Plunger makes 90° rotation.

### Step 6

Pressurize port B.  
Plunger retracts through workpiece.

## Selection chart

Clamping force <sup>1)</sup>	Stroke	Model number <sup>2)</sup>	Cylinder effective area		Oil capacity		Max. oil flow	Maximum cycle rate
			cm <sup>2</sup> Clamp.	cm <sup>2</sup> Unclamp.	cm <sup>3</sup> Clamp.	cm <sup>3</sup> Unclamp.		
kN	mm						l/min	cycles /min
22,2	63,5	<b>WTR-24</b>	6,3	11,4	41,0	72,1	1,9	4

<sup>1)</sup> When using optional CA-28 clamp arm, max. operating pressure is 138 bar.

<sup>2)</sup> Standard clamp arm included.

\* This product is made to order. Please contact Enerpac for delivery information before specifying in your design.

**WTR-24**

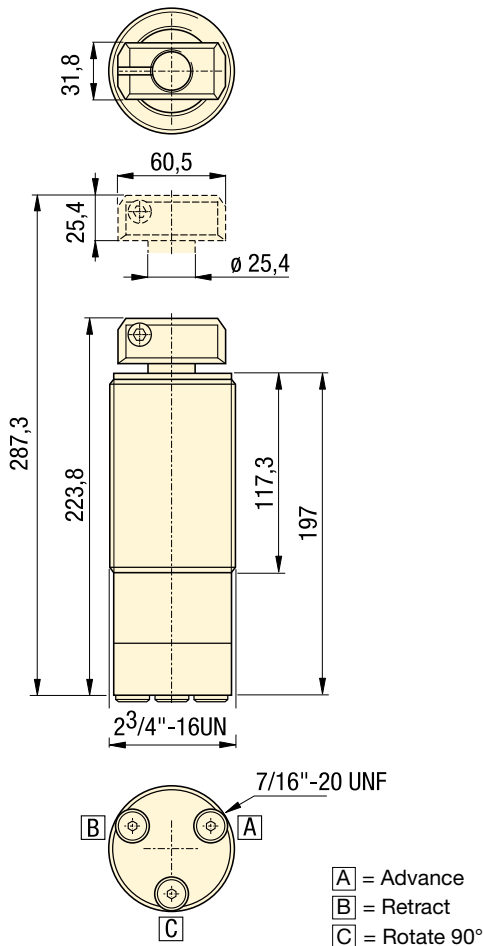

**Optional CA-28 clamp arm**

The WTR-24 has a two-sided standard clamp arm included. The CA-28 clamp arm can be used to secure the workpiece on one side only, though the clamping pressure must be reduced to 140 bar maximum.

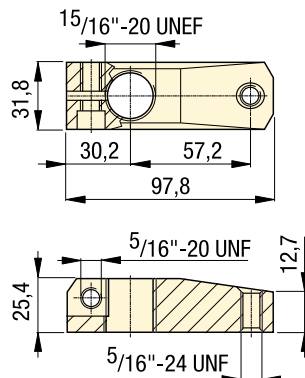

Force: 8,7 - 22,2 kN

Stroke: 63,5 mm

Pressure: 140 - 350 bar

- E** Cilindros giratorios
- F** Vérins de bridage pivotants
- D** Schwenkspannzylinder

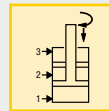

**Options**

High pressure filters

193 ▶



Fittings

194 ▶



Valves

136 ▶



**Important**

It is highly recommended that system filtration be used to ensure reliable operation.

Do not exceed maximum pressure and flow rates.

For recommended valving schemes, please refer to page 42.

Clamp arm movement: 90° ± 3° flat rotation.

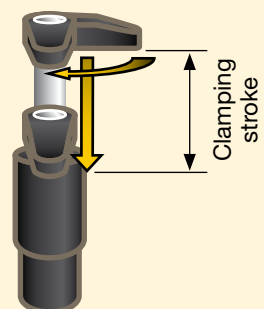

# WTR-series schematics

**⚠ Important**

Circuit must include a Pressure Reducing Valve (PRV-4) in the "A" port circuit to reduce the pressure in Unclamp to prevent damage to the cylinder.

## Recommended valving system for WTR-24

- 4-way 3-position closed center valves are recommended
- Valves can be manual or solenoid operated
- Valves must be cycled as shown for proper actuation of the WTR-24.

