

▼ Shown: ZC3308JE



Z Tough.
Dependable.
Innovative.
ZCLASS

High-Performance Battery Power

Productivity, Performance, Safety

- High-flow cordless solution saves users time and money by eliminating the need for using a generator and extension cords
- Brushless 1.4 hp motor and 3-stage pump maximizes pump and tool productivity while minimizing heat buildup and downtime
- The Lithium-Ion battery provides superior run time, even under extreme job site conditions, running approximately 50 cycles on a RC1006 and approximately 90 cycles on a RC504 cylinder on a single charge
- Convenient 10 ft. pendant cord for hassle-free operation
- Reduce noise level, 80 dba maximum
- Zero emission hydraulic power pack



Charger	
ZC115VC	115V
ZC230VC	230V
Battery*	
ZC82V4NA	82V
ZC82V4EUAU	82V

*NA is North America and EUAU is European and Australia



Gauges

Minimize the risk of overloading and ensure long, dependable service from your equipment.

Page: 147



High-Pressure Hoses

Enerpac offers a complete line of high-quality hydraulic hoses. To ensure the integrity of your system, specify only genuine Enerpac hydraulic hoses.

Page: 148



◀ Special Enerpac ZC3-Series pump used for rail stressing applications.

Cordless Hydraulic Pumps



ZC-Series Cordless Hydraulic Pump

The Enerpac ZC-Series pump combines the performance of an electric pump with the convenience and portability of a battery pump. This quiet, cordless solution is ideal for applications where emission and noise are a concern, or when electricity or air is not readily available.

Power for the pump is supplied by a rechargeable 82V Lithium-ion battery. The Lithium-ion battery is capable of providing impressive run times, even under extreme job site conditions.

Valve Options

- 4-way/3-position manual control valve used with double-acting cylinders
- 3-way/3-position manual control valve used with single-acting cylinders
- 4-way/3-position manual control valve with locking and power seat functions used in post tensioning concrete applications

Applications

- High-flow cordless solution for industrial applications
- Foundation repair
- Rail industry
- Post-tensioning concrete

ZC Series



Oil Capacity:

1.75 gallon

Flow at Rated Pressure:

32 in³/min.

Motor Size:

1.36 hp

Maximum Operating Pressure:

10,000 psi

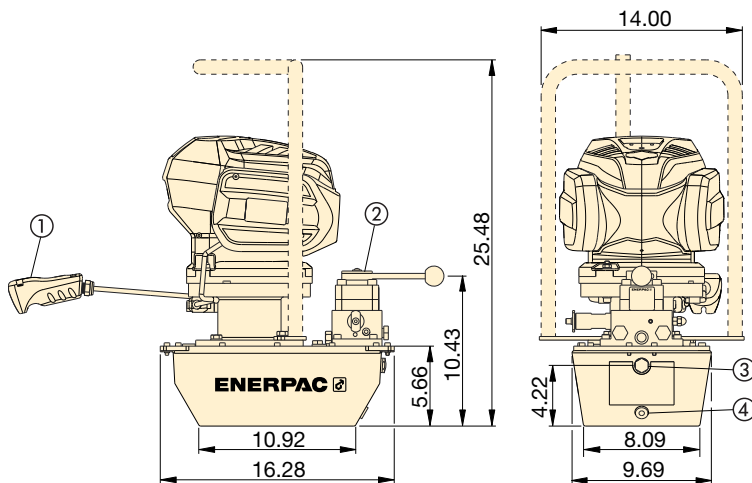

- ① Motor On/Off Remote Pendant
- ② VM43-LPS Valve Shown
- ③ Sight Glass
- ④ Oil Drain 1/2" NPTF

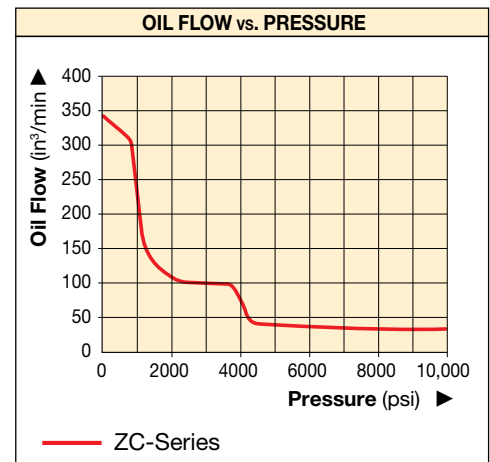

Used with	Oil Capacity (gal)	Manual Valve Model Number	Valve Function	Model Number*	Output Flow Rate (in ³ /min)			Charger Voltage (VAC)	Weight with Oil** (lbs)
					@ no load	@ 4000 psi	@ 10,000 psi		
Single-Acting Cylinder	1.75	VM33	Advance/Neutral/Retract	ZC3308JB	310	80	32	115	65.5
				ZC3308JE				230	
Double-Acting Cylinder	1.75	VM43	Advance/Neutral/Retract	ZC3408JB	310	80	32	115	65.5
				ZC3408JE				230	
Power Seater Post-Tensioning Tools	1.75	VM43LPS	Advance/Hold/Retract	ZC3908JB	310	80	32	115	73.4
				ZC3908JE				230	

* All models meet CE safety requirements and all TUV requirements. Pump includes one charger and battery.

** Weight including oil and battery. Battery weight = 5.7 lbs.