

Spin-on filter according to Hengst standard

Type 7 SL 30 ... 260; 7 SLS 90 ... 260

RE 51426

Edition: 2021-04

Replaces: -



- ▶ Nominal sizes: 7 SL 30 ... 260; 7 SLS 90 ... 260
- ▶ Nominal pressure 7 bar [101 psi]
- ▶ Connection up to G1 1/2, SAE 20

Features

Spin-on filters are used in mobile and industrial hydraulic systems for separating solid material from fluids and lubricating oils.

They distinguish themselves by the following:

- ▶ Filter for inline installation
- ▶ Optimized for mobile hydraulics, space-saving, service-friendly
- ▶ 7 SLS version with isolator valve, patented and environmentally-friendly
- ▶ Installation in suction, pressure or return lines possible
- ▶ Special, highly-efficient filter materials
- ▶ Filtration of ultra-fine particles and high dirt-holding capacity
- ▶ Optional version with maintenance indicator, pressure gauge or vacuum meter
- ▶ Optional bypass valve integrated in the filter housing

Contents

Features	1
Ordering codes filter	2, 3
Preferred types	4
Filter design	5
Symbols	6
Function, section	7
Technical data	8 ... 10
Compatibility with permitted hydraulic fluids	10
Dimensions	11 ... 14
Spare parts ordering codes	15
Installation, commissioning, maintenance	16
Tightening torques	17
Directives and standardization	18

Filter ordering codes

01	02	03	04	05	06	07	08	09	10	11	12
7				- S00	- 0			-		M	0

Pressure

01	Spin-on filter 7 bar [101 psi]	7
----	--------------------------------	---

Series

02	Spin-on filter without isolator valve	SL
	Spin-on filter with isolator valve	SLS

Size

03	7 SL...	30/21 45/21 60/21 90 130 180 ¹⁾ 260 ²⁾
	7 SLS...	90 130 180 ¹⁾ 260 ²⁾

Filter rating in µm

04	Absolute Glass fiber material, not cleanable (ISO 16889; β _{x(c)} ≥ 200)	H3XL H6XL H10XL H20XL
	Nominal Paper, not cleanable	P10 P25

Pressure differential

05	Max. permissible pressure differential of the filter element of 5 bar [72 psi]	S00
----	--	-----

Solenoid

06	Without	0
----	----------------	---

Bypass valve

07	Without	0
	Cracking pressure 0.3 bar [4.4 psi] – with maintenance indicator C; F0.2; G0.2 configurable	1
	Cracking pressure 2.5 bar [36.3 psi] – with maintenance indicator A; D1.5; H1.5; J1.5; P1.5 configurable	5

Maintenance indicator

08	Without	0
	Pressure gauge 0 ...6 bar [0 ... 87 psi]	A ³⁾
	Vacuum meter -1 ...0.6 bar [-14.5 ... 8.7 psi]	C
	Back pressure indicator, optical	D1.5
	Vacuum switch, normally open contact	F0.2
	Vacuum switch, normally closed contact	G0.2
	Pressure switch, normally open contact	H1.5
	Pressure switch, normally closed contact	J1.5
	Pressure differential indicator opt. / electr. with connector, changeover (only for 7 SL 90 ... 260)	P1.5

Ordering codes filter

01	02	03	04	05	06	07	08	09	10	11	12			
7				-	S00	-	0			-		M	0	

Port

09	Installation size	7 SL 30/21 ... 60/21	7 SL / SLS 90 ... 130	7 SL / SLS 180 ... 260	
	Port				
	ISO 228	G3/4	G1 1/4	G1 1/2	R0
	SAE flange 3000 psi			SAE1 1/2"	S0
	SAE J 1926		SAE20		U0

Seal

10	NBR	M
----	-----	----------

Housing material

11	Standard material	0
----	-------------------	----------

Supplementary information

12	Without	0
	Check valve in outlet (only with 7 SLS without bypass valve, not to be installed in suction lines)	R

- 1) The filter 7 SL(S) 180 contains two spin-on elements of size 90.
- 2) The filter 7 SL(S) 260 contains two spin-on elements of size 130.
- 3) When using a pressure gauge, the maximum permissible operating pressure is reduced to 6 bar [87 psi].

Order example:

7 SL 45/21 P10-S00-00H1,5-R0M00

Further versions (filter materials, connections,...) are available on request.

Preferred types

Spin-on filter, nominal pressure 7 bar, filter material and rating glass fiber material 10 µm

Type	Flow in l/min [gpm] with $v = 30 \text{ mm}^2/\text{s}$ [142 SUS] and $\Delta p = 0.5 \text{ bar}$ [7.25 psi] ¹⁾	Material no. Filter	Material no. Spin-on element
7 SL 45/21 H10XL-S00-05A-ROM00	40 [10.57]	R928028294	1x R928016611
7 SL 90 H10XL-S00-05A-ROM00	140 [36.98]	R928027821	1x R928016614
7 SL 130 H10XL-S00-05A-ROM00	150 [39.63]	R928025538	1x R928016617
7 SL 180 H10XL-S00-05A-ROM00	235 [62.08]	R928028301	2x R928016614
7 SL 260 H10XL-S00-05A-ROM00	255 [67.36]	R928028302	2x R928016617

Spin-on filter, nominal pressure 7 bar, filter material and rating paper, 10 µm

Type	Flow in l/min [gpm] with $v = 30 \text{ mm}^2/\text{s}$ [142 SUS] and $\Delta p = 0.5 \text{ bar}$ [7.25 psi] ¹⁾	Material no. Filter	Material no. Spin-on element
7 SL 45/21 P10-S00-05A-ROM00	45 [11.89]	R928028307	1x R928016609
7 SL 90 P10-S00-05A-ROM00	185 [48.87]	R928028310	1x R928016612
7 SL 130 P10-S00-05A-ROM00	190 [50.19]	R928028313	1x R928016615
7 SL 180 P10-S00-05A-ROM00	295 [77.93]	R928028316	2x R928016612
7 SL 260 P10-S00-05A-ROM00	300 [79.25]	R928028319	2x R928016615

Spin-on filter with return flow block, nominal pressure 7 bar, filter material and rating glass fiber material, 10 µm

Type	Flow in l/min [gpm] with $v = 30 \text{ mm}^2/\text{s}$ [142 SUS] and $\Delta p = 0.5 \text{ bar}$ [7.25 psi] ¹⁾	Material no. Filter	Material no. Spin-on element
7 SLS 90 H10XL-S00-05A-ROM00	135 [35.66]	R928028323	1x R928016614
7 SLS 130 H10XL-S00-05A-ROM00	150 [39.63]	R928028340	1x R928016617

Spin-on filter with return flow block, nominal pressure 7 bar, filter material and rating paper, 10 µm

Type	Flow in l/min [gpm] with $v = 30 \text{ mm}^2/\text{s}$ [142 SUS] and $\Delta p = 0.5 \text{ bar}$ [7.25 psi] ¹⁾	Material no. Filter	Material no. Spin-on element
7 SLS 90 P10-S00-05A-ROM00	185 [48.87]	R928028344	1x R928016612
7 SLS 130 P10-S00-05A-ROM00	190 [50.19]	R928028348	1x R928016615

¹⁾ Measured pressure differential across filter and measuring equipment in accordance with ISO 3968. The measured pressure differential at the maintenance indicator is lower.

Filter design

Easy selection of the filter size is made possible by the FilterSelect online tool. The filter can be designed using the operating pressure, flow and fluid system parameters. The required filter rating is based on the application, the sensitivity to contamination of the components and the environmental conditions.

The program leads you through the menu on a step-by-step basis.

A documentation of the filter selection can finally be created in the form of a PDF file. This file contains the entered parameters, the designed filter with material number including spare parts, and the pressure loss curves.

Link FilterSelect:

<http://www.filterselect.de>

Other languages can be selected using the page navigation.

standard search

application: hydraulics for industrial use and applications with lubricating oil

Product category: please select

type: please select

pressure range: please select

filter material: please select

fineness: please select

volume flow rate: [l/min]

viscosity:
 * = working point

kin viscosity 1: [mm²/s]

search via type of medium full-text search medium

temp 1: [°C] [°F] kin viscosity 1: [mm²/s]

dyn. Viscosity 1: [cP] density 1: [kg/dm³] kin viscosity 1: [mm²/s]

collapse pressure resistance according to ISO 2941:

Symbols (Dimensions in mm [inch])

Spare part	Back pressure gauge M 010	Vacuum gauge M 070	Optical/mechanical P1,500000M
Drawing			
Ordering code in the type key	A	C	D
Symbol			

Spare part	Pressure switch Normally open contact H1.5 HS 32 00M Normally closed contact H1.5 HA 32 00M	Vacuum switch Normally open contact I0.2 HS 32 00V Normally closed contact I0.2 HA 32 00V	Optical/electrical with connector
Drawing			
Ordering code in the type key	Normally open contact H Normally closed contact J	Normally open contact F Normally closed contact G	Changeover P
Symbol	<p>H: Normally open contact</p> <p>J: Normally closed contact</p>	<p>F: Normally open contact</p> <p>G: Normally closed contact</p>	

Function, section

General:

The spin-on filter is suited for direct installation in suction, pressure or return lines. It is installed upstream from components to be protected.

It consists primarily of a filter head (1), a threaded spin-on element (2) with built-in filter element (or two spin-on elements for sizes 180 and 260).

Optionally, a maintenance indicator (3) and a bypass valve (4) can also be configured for the filter.

The fluid passes through the inlet to the spin-on element (2), where it is cleaned. Any dirt particles that are filtered out collect in the filter element. The filtered fluid then enters the hydraulic circuit through the outlet. For sizes 180 and 260, fluid flows through both spin-on elements at the same time.

Spin-on filter with isolator valve 7 SLS:

The integrated check valve in the filter head prevents fluid from draining from the system while replacing the filter element (5) of the 7 SLS. During filter element change, the inlet side is blocked.

With the check valve (6) at the outlet - see supplementary information R - leakage is prevented from occurring on the clean side. (The filter is not suitable for installation in suction lines with this model.)

Maintenance indicator:

Special maintenance indicators are possible for the following applications:

Suction line: Vacuum meter or vacuum switch
Return line: Pressure gauge or pressure switch
Pressure line: Differential pressure switch

The location of the respective maintenance indicators is depicted in the chapter on "Dimensions".

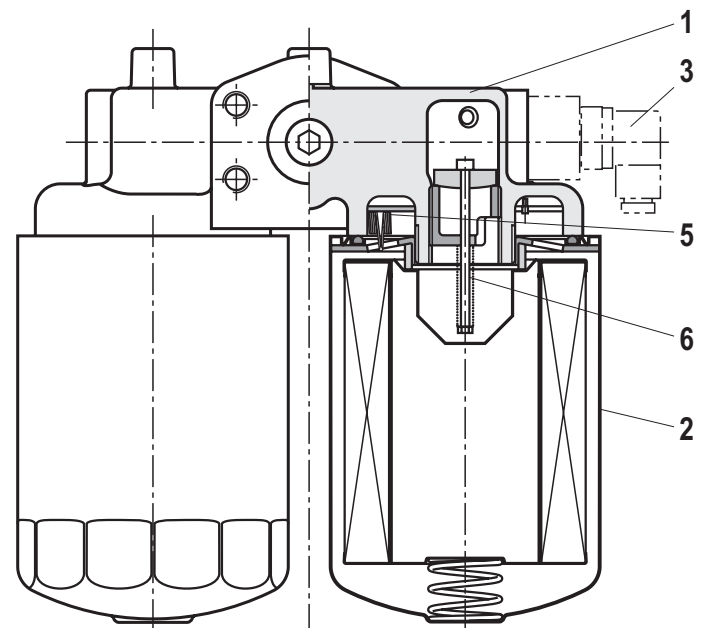
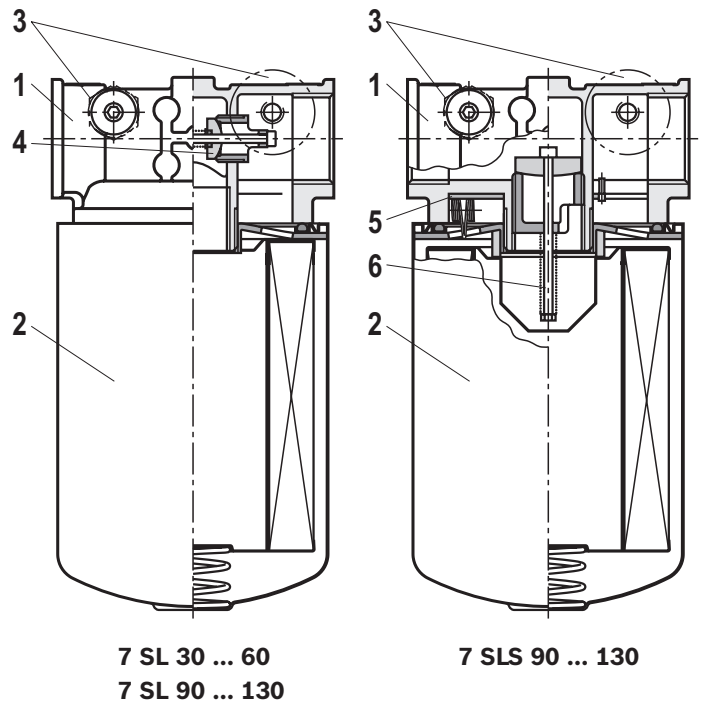

Note:

If the maintenance indicator warning is not adhered to, and the filter element is not changed on indication, the by-pass valve will open with the increase in differential pressure and part of the flow will be diverted passed the filter element, to the clean side without being filtered. Thus, effective filtration is no longer guaranteed.

Technical data

(Please consult us for applications outside these parameters!)

General						
Installation position		Vertical				
Ambient temperature range	°C [°F]	-40 ... +65 [-40... +149]				
Storage conditions	▶ NBR seal	°C [°F]	-40 ... +65 [+14... +149]; max. relative air humidity of 65%			
Mass	▶ 7 SL	Size	30/21	45/21	60/21	
		kg [lbs]	0.8 [1.8]	0.9 [2.0]	1.1 [2.4]	
	▶ 7 SLS	Size	90	130	180	260
		kg [lbs]	1.6 [3.5]	1.9 [4.2]	3.0 [6.6]	3.2 [7.1]
		Size	90	130	180	260
		kg [lbs]	1.8 [4.0]	2.1 [4.6]	3.3 [7.3]	3.5 [7.7]
Volume	▶ 7 SL	Size	30/21	45/21	60/21	
		l [US gal]	0.5 [0.1]		1.2 [0.3]	
	▶ 7 SLS	Size	90	130	180	260
		l [US gal]	2.0 [0.5]	2.7 [0.7]	2x 2.0 [2x 0.5]	2x 2.7 [2x 0.7]
		Size	90	130	180	260
		l [US gal]	2.0 [0.5]	2.7 [0.7]	2x 2.0 [2x 0.5]	2x 2.7 [2x 0.7]
Material	▶ Filter head	Aluminum				
	▶ Spin-on element	Steel				
	▶ Maintenance indicator	Aluminum / steel / brass / plastic				

Hydraulics		
Max. operating pressure	bar [psi]	7 [101.5]
Hydraulic fluid temperature range	°C [°F]	-10 ... +100 [+14... +212]
 Note about cold start:		-40 ... -10 [-40...+14] During the cold start up, expect a sudden pressure increase and a flow of at least 50% in each case. A bypass valve is essential.
Min. medium conductivity	pS/m	300
Fatigue strength as per ISO 10771	Load cycles	> 10 ⁶ at rated operating pressure

Technical data (Please consult us for applications outside these parameters!)

Maintenance indicator	Pressure gauge 0 ... 6 bar	Vacuum meter -1 ... +0.6 bar	Optical	Differential pressure indicator optical/electric	
Letter order option	A	C	D1.5	P1.5	
Model	M010	M070	P1.5000000M	F1.5GW0200M	
Contact load, direct voltage	A _{max.}	-			
Voltage range	V _{max.}				0.25
Max. switching power	VA				175 AC/DC
Switching type	▶ 100% signal				5
Protection class as per EN 60529	IP				Changeover
Ambient temperature range	°C [-10 ... +60] [°F] [+14 ... +140]	-10 ... +60 [-10 ... +60] [°F] [+14 ... +140]	-10 ... +85 [-10 ... +85] [°F] [+14 ... +185]	-10 ... +85 [-10 ... +85] [°F] [+14 ... +185]	
Operating temperature	°C [-10 ... +60] [°F] [+14 ... +140]	-10 ... +60 [-10 ... +60] [°F] [+14 ... +140]	-10 ... +85 [-10 ... +85] [°F] [+14 ... +185]	-10 ... +100 [-10 ... +100] [°F] [+14 ... +212]	
Include spark extinguishing for DC voltage above 24 V to protect the switching contacts.					
Mass	kg [lbs]	0.06 [0.13]	0.05 [0.11]	0.02 [0.04]	0.3 [0.66]
Material	▶ Housing	Plastic/brass	Plastic/steel/ phosphor bronze	Aluminum / plastic/steel	Aluminum / plastic/brass
	▶ Seals	-	-	NBR	NBR

Maintenance indicator	Back pressure indicator electrical	Back pressure indicator electrical	Vacuum switch electrical	Vacuum switch electrical	
Letter order option	H1.5	J1.5	F0.2	G0.2	
Model	H1.5HS3200M	H1.5HA3200M	I0.2HS3200V	I0.2HA3200V	
Contact load, direct voltage	A _{max.}	4			
Voltage range	V _{max.}	42 AC			
Max. switching power	VA	100			
Switching type	▶ 100% signal	Normally open contact	Normally closed contact	Normally open contact	Normally closed contact
Protection class as per EN 60529	IP	54			
Ambient temperature range	°C [-10 ... +100] [°F] [+14 ... +212]	-20 ... +85 [-20 ... +85] [°F] [-4 ... +185]	-10 ... +70 [-10 ... +70] [°F] [14 ... +158]	-20 ... +70 [-20 ... +70] [°F] [-4 ... +158]	
Operating temperature	°C [-10 ... +100] [°F] [+14 ... +212]	-20 ... +100 [-20 ... +100] [°F] [-4 ... +212]	-10 ... +100 [-10 ... +100] [°F] [+14 ... +212]	-20 ... +100 [-20 ... +100] [°F] [-4 ... +212]	
Include spark extinguishing for DC voltage above 24 V to protect the switching contacts.					
Mass	kg [lbs]	0.1 [0.22]	0.1 [0.22]	0.17 [0.37]	0.17 [0.37]
Material	▶ Housing	Steel	Steel	Brass	Brass
	▶ Seals	NBR	NBR	FKM	FKM

Technical data (Please consult us for applications outside these parameters!)

Filter element			
Glass fiber material H...XL		Inorganic fiber-based single-use element	
		Filtration ratio as per ISO 16889 up to $\Delta p = 5 \text{ bar}$ [72.5 psi]	Best oil cleanliness as per ISO 4406 [SAE-AS 4059]
Particle separation	H20XL	$\beta_{20}(c) \geq 200$	19/16/12 – 22/17/14
	H10XL	$\beta_{10}(c) \geq 200$	17/14/10 – 21/16/13
	H6XL	$\beta_6(c) \geq 200$	15/12/10 – 19/14/11
	H3XL	$\beta_5(c) \geq 200$	13/10/8 – 17/13/10
Permissible pressure differential	– S00	bar [psi]	5 [72.5]

Compatibility with permitted hydraulic fluids

Hydraulic fluid	Classification	Suitable sealing materials	Standards
Mineral oils	HLP	NBR	DIN 51524

Dimensions: 7 SL 30 ... 60, 7 SL 90 ... 130, 7 SLS 90 ... 130
(dimensions in mm [inch])

7 SL 30 ... 60
7 SL 90 ... 130
7 SLS 90 ... 130

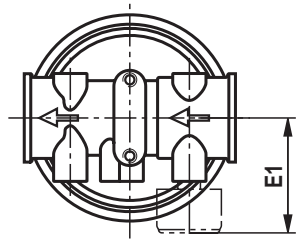

A = M010
Pressure gauge for size 30 ... 60
in port D

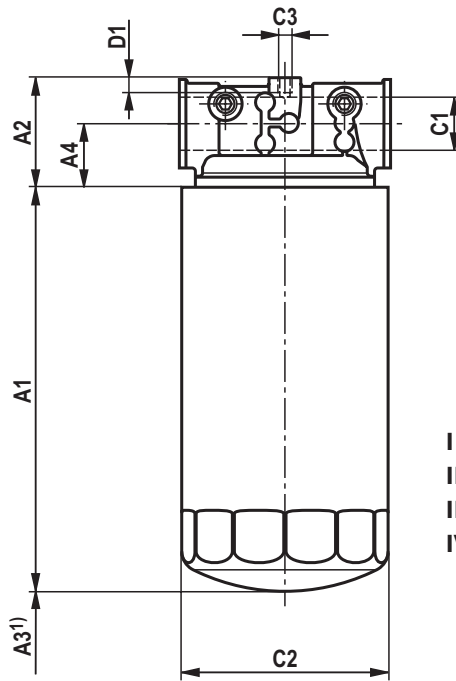

- I = Vacuum meter/vacuum switch
 - II = Pressure gauge/pressure switch
 - III = Vacuum meter/vacuum switch
 - IV = Pressure gauge/pressure switch
- (only with size 30 ... 60)

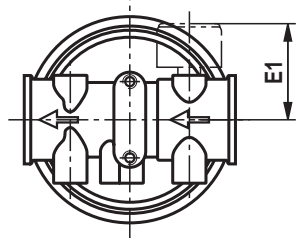

A = M010
Pressure gauge for size 90 ... 130
in port B

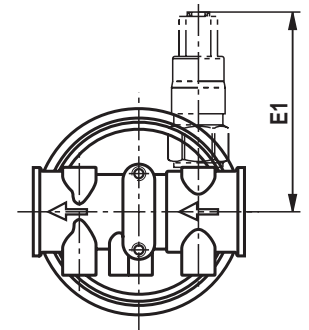
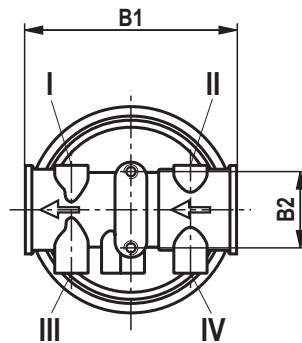

D1.5 = P1.5
Back pressure indicator
optical in port B

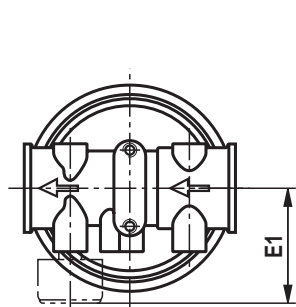

C = M070
Vacuum meter
in connection C

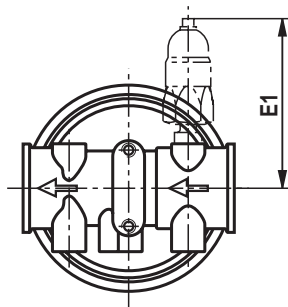

H1.5 = H1.5HS3200M
Pressure switch normally
open contact
J1.5 = H1.5HA3200M
Pressure switch normally
closed contact in port B

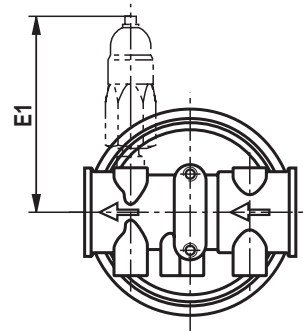

F0.2 = I0.2HS3200V
Vacuum switch normally
open contact
G0.2 = I0.2HA3200V
vacuum switch normally
closed contact in port A

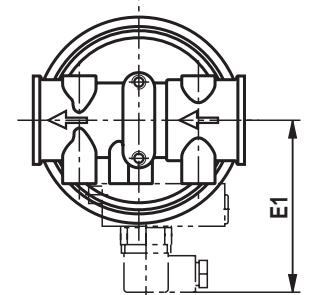

P1.5 = P1.5GW0200M
Pressure differential
indicator optical-electr.,
changeover with
connector at flange
connection

Dimensions: 7 SL 30 ... 60, 7 SL 90 ... 130, 7 SLS 90 ... 130(dimensions in mm [*inch*])

Filter type	I	II	III	IV	WA flange connection
7 SL 30 ... 60	G1/8	G1/8	G1/8	G1/8	not possible
7 SL 90 ... 130	G1/8	G1/8	G1/8	-	optional

Filter type	A1	A2	A3 ¹⁾	A4	B1	B2	C1			ØC2	C3
							R...	S...	U...		
7 SL 30/21	95 [3.74]	41 [1.61]	20 [0.79]	20 [0.79]	95 [3.74]	38 [1.50]	G3/4	-	-	92 [3.62]	M8
7 SL 45/21	146 [5.75]										
7 SL 60/21	205 [8.07]										
7 SL 90	183 [7.20]	69 [2.72]		40 [1.57]	133 [5.24]	48 [1.89]	G1 1/4	-	1 5/8"-12 UN	128 [5.04]	
7 SL 130	231 [9.09]										
7 SLS 90	183 [7.20]										
7 SLS 130	231 [9.09]										

Filter type	D1	E1 approx.								Connection spin-on element
		A	C	D1.5	F0.2	G0.2	H1.5	J1.5	P1.5	
7 SL 30/21	10 [0.39]	54 [2.13]	54 [2.13]	118 [4.65]	116 [4.57]	116 [4.57]	99 [3.90]	99 [3.90]	-	G3/4
7 SL 45/21										
7 SL 60/21										
7 SL 90	15 [0.59]	72 [2.83]	72 [2.83]	124 [4.88]	122 [4.80]	122 [4.80]	117 [4.61]	117 [4.61]	107 [4.21]	G1 1/4
7 SL 130										
7 SLS 90										
7 SLS 130										

Filter type	Installation position - maintenance indicator								
	A	C	D1.5	F0.2	G0.2	H1.5	J1.5	P1.5	
	M010 Pressure gauge	M070 Vacuum meter	P1,5 Back pressure indicator	I0.2HS3200M Vacuum switch normally open contact	I0.2HA3200M Vacuum switch normally closed contact	H1.5HS3200M Pressure switch normally open contact	H1.5HA3200M Pressure switch nor- mally closed contact	F1.5GW0200M Differential pressure indicator optical-electr. with connector	
7 SL 30 ... 60	IV	III	II	I	I	II	II	-	
7 SL 90 ... 130	II	III	II	I	I	II	II	Flange connection	
7 SL 180 ... 260	II	-	II	-	-	II	II	Flange connection	
7 SLS 90 ... 130	-	III	-	I	I	-	-	-	
7 SLS 180 ... 260	II	-	II	-	-	II	II	Flange connection	

¹⁾ Servicing height for spin-on element

Dimensions: 7 SL 180 ... 260, 7 SLS 180 ... 260
(dimensions in mm [inch])

7 SL 180 ... 260
7 SLS 180 ... 260

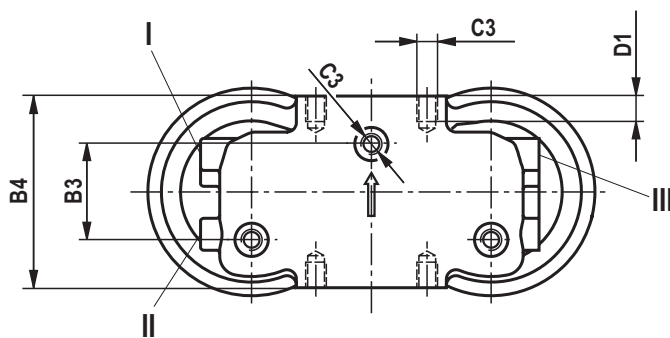
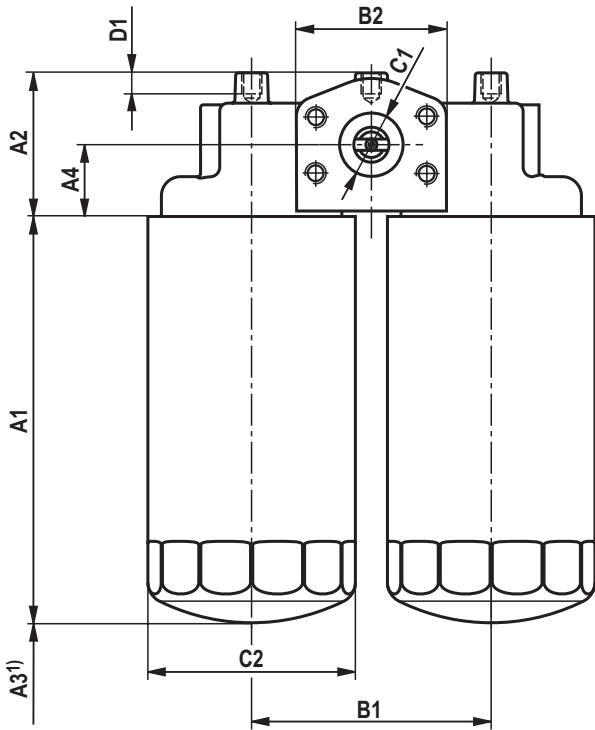

C = M070, Vacuum meter
in port A

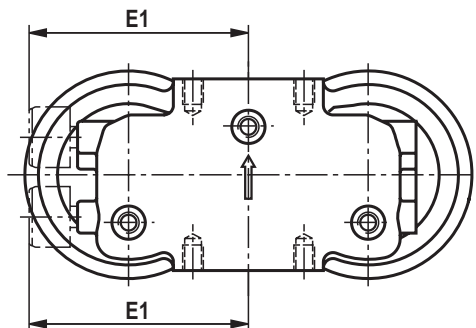

A = M010, Pressure gauge
in port B

Port for:

- I = Vacuum meter/vacuum switch**
- II = Pressure gauge/pressure switch**
- III = Differential pressure indicator**

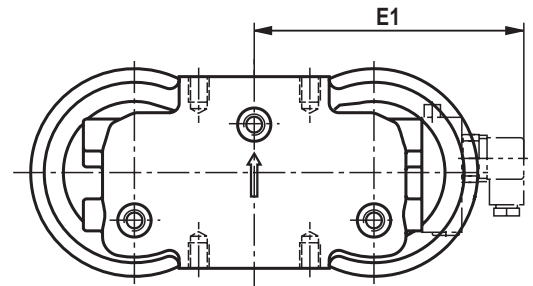

P1.5 = F1.5GW0200M
Pressure differential indicator optical/
electric with connector at flange connection

F0.2 = I0.2HS3200V, Vacuum switch normally
open contact
G0.2 = I0.2HA3200V, Vacuum switch normally
closed contact in port A

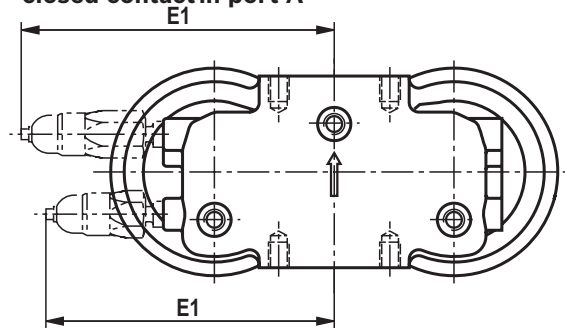

H1.5 = H1.5HS3200M, Pressure switch normally
open contact
J1.5 = H1.5HA3200M Pressure switch normally
closed contact in port B

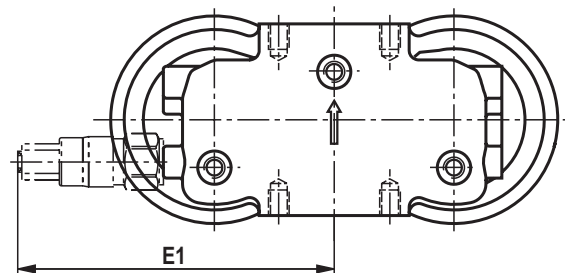

D1.5 = P1.5, Back pressure indicator optical
in port B

Dimensions: 7 SL 180 ... 260, 7 SLS 180 ... 260(dimensions in mm [*inch*])

Filter type	I	II	III	WA flange connection
7 SL 180 ... 260	–	G1/8	–	possible
7 SLS 90 ... 130	G1/4	M14 x 1.5	G1/4	not possible
7 SLS 180 ... 260	–	G1/8	–	possible

Filter type	A1	A2	A3 ¹⁾	A4	B1	B2	B3	B4	R...	C1			ØC2	C3
										S...	U...			
7 SL 180	183 [7.20]	90 [3.54]	20 [0.79]	44 [1.73]	150 [5.91]	94 [3.70]	60 [2.36]	120 [4.72]	G1 1/2	SAE 1 1/2"-3000psi			128 [5.04]	M12
7 SL 260	231 [9.09]			SAE1 1/4" - 3000 psi										
7 SLS 180	183 [7.20]	SAE1 1/2" - 3000 psi												
7 SLS 260	231 [9.09]	SAE1 1/2" - 3000 psi												

Filter type	D1	E1 approx.								Connection spin-on element
		A	C	D1.5	F0.2	G0.2	H1.5	J1.5	P1.5	
7 SL 180	15 [0.59]	140 [5.51]	–	204 [8.03]	–	–	185 [7.28]	185 [7.28]	175 [6.89]	G1 1/4
7 SL 260										M 42 x 2
7 SLS 180										
7 SLS 260										

Filter type	Installation position - maintenance indicator								
	A	C	D1.5	F0.2	G0.2	H1.5	J1.5	P1.5	
	M010 Pressure gauge	M070 Vacuum meter	P1.5 Back pressure indicator	I0.2HS3200M Vacuum switch normally open contact	I0.2HA3200M Vacuum switch normally closed contact	H1.5HS3200M Pressure switch nor- mally open contact	H1.5HA3200M Pressure switch nor- mally closed contact	F1.5GW0200M Differential pressure indicator optical-electr. with connector	
7 SL 180 ... 260	II	–	II	–	–	II	II		Flange connection
7 SLS 90 ... 130	–	III	–	I	I	–	–		–
7 SLS 180 ... 260	II	–	II	–	–	II	II		Flange connection

1) Servicing height for spin-on element

Spare parts ordering codes

Spin-on element

01	02	03	04	05	06
			- S00	- 0	- M

Design

01	7 SL 30/20 ... 130	80
	7 SLS 90 ... 130	81

Size

02	7 SL... for 7 SL 180, 2 spin-on elements 80.90 are required for 7 SL 260, 2 spin-on elements 80.130 are required	30/21 45/21 60/21 90 130
	7 SLS... for 7 SLS 180, 2 spin-on elements 81.90 are required for 7 SLS 260, 2 spin-on elements 80.130 are required	90 130

Filter rating in µm

03	Absolute (ISO 16889; $\beta_x(c) \geq 200$)	Glass fiber material, not cleanable	H3XL H6XL H10XL H20XL
	Nominal	Paper, not cleanable	P10 P25

Pressure differential

04	Max. permissible pressure differential of the filter element of 5 bar [72 psi]	S00
----	--	-----

Bypass valve

05	Without bypass valve	0
----	-----------------------------	---

Seal

06	NBR	M
----	-----	---

Order example:

80.45/21 P10-S00-0-M

Maintenance indicator

Description	Material no.
M010 ¹⁾	R928019224 (without seal)
M070	R928025266 (without seal)
P1.5000000M	R928019225
H1.5HS3200M	R928019219
H1.5HA3200M	R928019205
I0.2HS3200V	R928035839
I0.2HA3200V	R928037068
F1.5GW0200M	R928019336

¹⁾ When using a pressure gauge, the maximum permissible operating pressure is reduced to 6 bar [87 psi].

Installation, commissioning, maintenance

Installation

- ▶ The max. operating pressure of the system cannot exceed the max. permissible operating pressure of the filter (see name plate).
- ▶ During assembly of the filter the flow direction (direction arrows) and the required servicing height of the spin-on element (see chapter "Dimensions") are to be considered.
- ▶ Cartridge replacement is made easiest when the spin-on element is oriented downward with the installation position.
- ▶ The maintenance indicator must be arranged so it is easily viewed in operation.
- ▶ Remove the plastic plugs from the filter inlet and outlet.
- ▶ The connection of the electrical maintenance indicator is via a mating connector that is attached to the maintenance indicator contacts and held by a screw or, in the cases of versions H, J, F and G, it is laid directly onto the contacts using a rubber bushing.

Commissioning

- ▶ Commission the system.

Note:

The filter has no bleeding mechanism.

Maintenance

- ▶ If at operating temperature, the red indicator pin reaches out of the mechanical optical maintenance indicator or if the switching process in the electronic switching element is triggered, the spin-on element is dirty and needs to be replaced.

Note:

Sizes 180 and 260 have two spin-on elements, through which fluid flows at the same time and which need to be replaced during maintenance.

- ▶ The material number of the correct spin-on element is on the name plate of the filter assembly. Verify that it matches the material number on the spin-on element.
- ▶ Decommission the system.
- ▶ Release operating pressure on the system side.

Note:

The filter has no bleeding mechanism.

- ▶ Unscrew the spin-on element.

Note:

Sizes 180 and 260 have two spin-on elements, through which fluid flows at the same time and which need to be replaced during maintenance.

- ▶ Screw on the new spin-on element hand-tight.

Please note:

- If necessary, carefully tighten it in the depressurized state (use a band wrench if necessary)
- ▶ Commission the system.
- ▶ If filter loosens between the spin-on element and filter head after commissioning, the spin-on element will need to be tightened up.

WARNING!

- ▶ Only install or remove when system is not pressurized.
- ▶ Tank is pressurized!
- ▶ Only remove spin-on element when it is not pressurized.
- ▶ Do not replace maintenance indicator when filter is pressurized.
- ▶ Failure to observe flow of direction during assembly will cause filter element to be damaged beyond repair. Particles will enter the system and damage downstream components.

Important:

- ▶ Only trained specialists may work on the filter.
- ▶ Proper function and safety are only guaranteed if original Hengst spin-on elements and spare parts are used.
- ▶ Warranty becomes void if the delivered item is changed by the ordering party or third parties or improperly mounted, installed, maintained, repaired, used or exposed to environmental condition that do not comply with the installation conditions.

Tightening torques

(dimensions in mm [inch])

Series 7 SL...	30/21	45/21	60/21	90	130	180	260
Tightening screws with $\mu_{\text{total}} = 0.14$ Nm [lbf-ft]	Max. 6 [4.4]			Max. 10 [7.4]		Max. 20 [14.8]	
Mounting screw	2 x M8					3 x M12	
Minimum screw-in depth mounting	8 [0.31]			12 [0.47]		10 [0.39]	

Series 7 SLS...	90	130	180	260
Tightening screws with $\mu_{\text{total}} = 0.14$ Nm [lbf-ft]	Max. 10 [7.4]		Max. 20 [14.8]	
Mounting screw	2 x M8		2 x M12	
Minimum screw-in depth mounting	12 [0.47]		10 [0.39]	

Maintenance indicators

Type	M010	M070	P1.5000000M	F1.5GW0200M	H1.5HS3200M	H1.5HA3200M	I0.2HS3200V	I0.2HA3200V
Screw/tightening torque with $\mu_{\text{total}} = 0.14$ Nm [lbf-ft]	conically sealing / no information possible		Max. 20 [14.8]		Max. 40 [29.5]		Max. 20 [14.8]	
Quantity	-			4	-			

Directives and standardization

Product validation

Hengst filters, the filter elements built into them and filter accessories are tested and quality-monitored according to different ISO test standards:

Pressure pulse test	ISO 10771:2015-08
Filtration performance test (multipass test)	ISO 16889:2008-06
Δp (pressure loss) characteristic curves	ISO 3968:2001-12
Compatibility with hydraulic fluid	ISO 2943:1998-11
Collapse pressure test	ISO 2941:2009-04

The development, manufacture and assembly of Hengst industrial filters and Hengst filter elements is carried out within the framework of a certified quality management system in accordance with ISO 9001:2015.

Classification according to the Pressure

Equipment Directive

The spin-on filters for hydraulic applications according to 51426 are pressure holding equipment according to article 1, section 2.1.4 of the Pressure Equipment Directive 97/23/EC (PED). However, under Article 1 Section 3.6 PED, hydraulic filters are exempt from the PED

if they are not classified higher than Category I (Guideline 1/19).

The fluids from the chapter "Compatibility with approved pressure fluids" were considered for the classification. They do not receive a CE mark.

Use in explosive areas

according to Directive 94/9/EC (ATEX)

The spin-on filters without maintenance indicator or with a mechanical-optical maintenance indicator according to 51426 are not equipment or components in the sense of directive 94/9/EC and are not provided with a CE mark. The ignition risk analysis showed that these spin-on filters do not have their own ignition sources as per DIN EN 13463-1:2009.

Spin-on filters and the mechanical-optical maintenance indicators described here can be used in the following explosive areas:

	Zone suitability	
	1	2
Gas		
Dust	21	22

Complete filter with mech./opt. Maintenance indicator, pressure gauge, vacuum meter

Use/assignment	Gas 2G	Dust 2D
Assignment	Ex II 2G c IIC TX	Ex II 2D c IIC TX
Medium conductivity $\mu\text{S/m}$	300	
Dust accumulation	–	0.5 mm

WARNING!

- ▶ Explosion hazard due to high temperature! Temperature is based on temperature of medium in hydraulic circuit and cannot exceed this value. Take steps to make sure max. permissible ignition temperature is not exceeded in explosive area.
- ▶ When using the spin-on filters according to 51426 in explosive areas, sufficient equipotential bonding has

- to be ensured. Grounding the filter with mounting screws is recommended. It has to be noted in this connection that paintings and oxidic protective layers are not electrically conductive.
- ▶ During spin-on filter replacement, the packaging material is to be removed from the replacement element outside the potentially explosive area.

Important:

- ▶ Maintenance may only be performed by specialists on instruction of the owner in accordance with Directive 1999/92/EC Annex II Section 1.1.
- ▶ Functional and safety warranty is only applicable when using original Hengst spare parts

Notes

Hengst Filtration GmbH
Hardtwaldstr. 43
68775 Ketsch, Germany
Phone +49 (0) 62 02 / 6 03-0
hydraulicfilter@hengst.de
www.hengst.com

© This document, as well as the data, specifications and other information set forth in it, are the exclusive property of Hengst Filtration GmbH. It may not be reproduced or given to third parties without consent of Hengst Filtration GmbH. The data specified above only serve to describe the product. No statements concerning a certain condition or suitability for a certain application can be derived from our information. The information given does not release the user from the obligation of own judgment and verification. It must be remembered that our products are subject to a natural process of wear and aging.

Notes

Hengst Filtration GmbH
Hardtwaldstr. 43
68775 Ketsch, Germany
Phone +49 (0) 62 02 / 6 03-0
hydraulicfilter@hengst.de
www.hengst.com

© This document, as well as the data, specifications and other information set forth in it, are the exclusive property of Hengst Filtration GmbH. It may not be reproduced or given to third parties without consent of Hengst Filtration GmbH. The data specified above only serve to describe the product. No statements concerning a certain condition or suitability for a certain application can be derived from our information. The information given does not release the user from the obligation of own judgment and verification. It must be remembered that our products are subject to a natural process of wear and aging.